



Republic of Namibia
Annotated Statutes

REGULATIONS

REGULATIONS MADE IN TERMS OF

Road Traffic and Transport Act 22 of 1999

section 91

Road Traffic and Transport Regulations, 2001

Government Notice 53 of 2001

[\(GG 2503\)](#)

In terms of GN 53/2001, the regulations came into force on 6 April 2001 *with the exception of* Parts 3 and 5 of Chapter 3, Chapter 4, Parts 1 and 2 of Chapter 5, Parts 2 and 4 of Chapter 6 and regulation 235.

Part 1 of Chapter 4 and Part 1 of Chapter 5 were brought into force on 1 November 2001 by GN 222/2001 [\(GG 2641\)](#). Part 2 of Chapter 4 was brought into force on 2 September 2002 by GN 161/2002 [\(GG 2815\)](#). Part 2 of Chapter 5 was brought into force on 17 November 2007 by GN 172/2007 [\(GG 3907\)](#).

GN 86/2017 [\(GG 6285\)](#) states that it is bringing Part 3 of *Chapter 10* into force on 13 April 2017. However, this must have been intended to refer to Part 3 of *Chapter 3*, which is amended by the same Government Notice. Chapter 10 was not divided into parts and was already in force.

Part 5 of Chapter 3 and Part 4 of Chapter 6 were brought into force on 30 September 2022 by GN 293/2022 [\(GG 7917\)](#).

The other excluded provisions are not yet in force:

- * Chapter 6, Part 2
- * regulation 235.

as amended by

Government Notice 97 of 2001 [\(GG 2538\)](#)

came into force on date of publication: 29 May 2001

Government Notice 103 of 2002 [\(GG 2759\)](#)

came into force on date of publication: 1 July 2002

Government Notice 163 of 2002 [\(GG 2815\)](#)

came into force on date of publication: 26 September 2002

Government Notice 205 of 2004 [\(GG 3287\)](#)

came into force on date of publication: 28 September 2004

The regulations were amended by Government Notice 206 of 2004 [\(GG 3287\)](#) which was to come into force on a date set by the Minister in the *Government Gazette*. However, Government Notice

REGULATIONS
Road Traffic and Transport Act 22 of 1999
Road Traffic and Transport Regulations, 2001

206 of 2004 was withdrawn by GN 45 of 2005 ([GG 3422](#)) without ever coming into force. Therefore, the amendments in that Government Notice never took effect.

- Government Notice 32 of 2005** ([GG 3402](#))
 came into force on date of publication: 1 April 2005
- Government Notice 45 of 2005** ([GG 3422](#))
 came into force on date of publication: 9 May 2005
- Government Notice 183 of 2005** ([GG 3560](#))
 came into force on date of publication: 20 December 2005
- Government Notice 188 of 2006** ([GG 3732](#))
 came into force on date of publication: 1 November 2006
- Government Notice 104 of 2007** ([GG 3851](#))
 came into force on 4 June 2007 (GN 104/2007)
- Government Notice 172 of 2007** ([GG 3907](#))
 came into force on date of publication: 17 September 2007
- Government Notice 2 of 2008** ([GG 3972](#))
 came into force on date of publication: 2 January 2008
- Government Notice 73 of 2008** ([GG 4022](#))
 came into force on date of publication: 1 April 2008
- Government Notice 290 of 2008** ([GG 4186](#))
 came into force on date of publication: 19 December 2008
- Government Notice 81 of 2010** ([GG 4473](#))
 came into force on date of publication: 30 April 2010
- Government Notice 156 of 2015** ([GG 5792](#))
 came into force on date of publication: 28 July 2015
- Government Notice 98 of 2016** ([GG 6016](#))
 came into force on date of publication: 26 May 2016
- Government Notice 86 of 2017** ([GG 6285](#))
 came into force on date of publication: 13 April 2017
- Government Notice 130 of 2018** ([GG 6637](#))
 came into force on date of publication: 29 June 2018
- Government Notice 31 of 2019** ([GG 6844](#))
 came into force on date of publication: 15 February 2019
- Government Notice 102 of 2020** ([GG 7172](#))
 came into force on date of publication: 3 April 2020
- Government Notice 298 of 2021** ([GG 7716](#))
 came into force on date of publication: 31 December 2021

Several of these Government Notices erroneously state that the regulations were amended by GN 222/2001 ([GG 2641](#)) and GN 161/2002 ([GG 2815](#)). However, these two notices deal only with the commencement of various portions of the regulations.

Section 94 of the Act empowers the Minister to incorporate any standard publication in any regulation issued under section 91, 92 or 93 of the Act by reference. The Minister utilised this power in GN 262/2020 ([GG 7373](#)) to incorporate the Namibian Standards (NAMS) published under General Notice 362/2018 ([GG 6649](#)) and General Notice 590/2018 ([GG 6737](#)) into these regulations.

GN 262/2020 omits the number of the General Notice published on 15 October 2018, but the General Notice referred to is obviously General Notice 590/2018, which announces the standards listed in GN 262/2020.

No.	Namibian Standard (NAMS) Code	Particulars and Description of Namibian Standard
1.	NAMS/SANS 10216:2018	Evaluation of Vehicle Testing Stations
2.	NAMS/SANS 10047:2018	Testing of Motor Vehicles for Roadworthiness
3.	NAMS/SANS 1518:2018	Transport of Dangerous Goods - Design, Construction, Testing, Approval & Maintenance of road vehicles and portable tanks

REGULATIONS
Road Traffic and Transport Act 22 of 1999
Road Traffic and Transport Regulations, 2001

4.	NAMS/SANS 10229-1:2018	Transport of dangerous goods - Packaging and large packaging for road and rail transport Part 1: Packaging
5.	NAMS/SANS 10229-2:2018	Transport of dangerous goods - Packaging and large packaging for road and rail transport Part 2: Large Packaging
6.	NAMS/SANS 10228:2018	The identification and classification of dangerous goods for transport by road and rail modes
7.	NAMS/SANS 10231:2018	Transport of dangerous goods - Operational requirements
8.	NAMS/SANS 10233:2018	Transport of dangerous goods - Intermediate bulk containers for road and rail transport
9.	NAMS/SANS 1116-1:2018	Retro-reflective number plates for motor vehicles - Part 1: Blank plates (Aluminium)
10.	NAMS/SANS 1116-2:2018	Retro-reflective number plates for motor vehicles - Part 2: Number plates (Aluminium)
11.	NAMS/SANS 1055:2018	Rear under run protective device
12.	NAMS/SANS 1496:2018	Wheel flaps fitted to motor vehicles
13.	NAMS/SANS 1046:2018	Lights and light-signalling devices installed on motor vehicles and trailers

ARRANGEMENT OF REGULATIONS

CHAPTER 1
DEFINITIONS

1. Definitions

CHAPTER 2
AUTHORISED OFFICERS

2. Registration of authorised officers
3. Qualification for authorised officers
4. Manner of application for registration in category of authorised officer
5. Requirements for competency and registration to be complied with by applicant to be registered in category of authorised officer
6. Manner of registration of authorised officers
7. Change of registration particulars
8. Grades of vehicle examiners and driving examiners
9. Suspension or revocation of registration of authorised officers
[heading of regulation 9 substituted by GN 183/2005]
10. Appeal procedure

CHAPTER 3
REGISTRATION AND LICENSING OF MOTOR VEHICLES AND
INCIDENTAL MATTERS

PART I
REGISTRATION OF MOTOR VEHICLES

11. Motor vehicle to be registered
12. Motor vehicle deemed to be registered
13. Motor vehicle exempt from registration
14. Date on which registration of motor vehicle becomes void

REGULATIONS
Road Traffic and Transport Act 22 of 1999
Road Traffic and Transport Regulations, 2001

15. Date and conditions on which motor vehicle is to be registered
16. Manner of application for registration of motor vehicle
- 16A. Application for duplicate document
[regulation 16A inserted by GN 156/2015]
17. Additional requirements for registration of motor vehicle built up from parts
18. Additional requirements for registration of deregistered motor vehicle
- 18A. Additional requirements for registration of a motor vehicle deregistered pursuant to regulation 32A
[regulation 18A inserted by GN 31/2019]
19. Additional requirements for registration of motor vehicle acquired from deceased estate
20. Additional requirements for registration of motor vehicle acquired due to repossession by title-holder
21. Additional requirements for registration of motor vehicle that is registered outside borders of Namibia
22. Manner of registration of motor vehicle
23. Manner of registration by a manufacturer, builder or importer who is registering authority
24. Deregistration of registered motor vehicle which becomes exempt from registration

PART 2
LICENSING OF MOTOR VEHICLES

25. Motor vehicle to be licensed
26. Motor vehicle deemed to be licensed
27. Motor vehicle exempt from licensing
28. Motor vehicle exempt from motor vehicle licence fees
29. Date on which motor vehicle licence and licence disc of motor vehicle becomes void
30. Date on which motor vehicle is to be licensed
31. Manner of application for licensing of motor vehicle
32. Manner of licensing of motor vehicle
- 32A. Automatic deregistration of a motor vehicle not licenced within the prescribed period
[regulation 32A inserted by GN 31/2019]
33. Period of validity of motor vehicle licence and licence disc
34. Licence number of motor vehicle
35. Minister may change allocated licence number
36. Specific licence numbers
- 36A. Transfer of a licence number
[regulation 36A inserted by GN 45/2005]
37. Personalised licence numbers
38. Application for personalised licence number
39. Issue of personalised licence number
- 39A. Conditions of the certificate of entitlement
- 39B. Circumstances under which a personalised licence number may be retained or transferred
- 39C. Retention or transfer of personalised licence number in case of change of owner or title holder of motor vehicle to which personalised licence number was allocated
- 39D. Transfer of right to personalised licence number by holder to another person
- 39E. Transfer of personalised licence number between motor vehicles of which holder of right to personalised licence number is owner or title holder
- 39F. Voluntary surrender of right to a personalised licence number
[regulations 39A-39F inserted by GN 104/2007]
40. Annual renewal fee
[heading of regulation 40 substituted by GN 104/2007]
41. Circumstances when personalised number plates become void
[heading of regulation 41 substituted by GN 104/2007]
42. Right of appeal to the Commission in respect of personalised number plates

REGULATIONS
Road Traffic and Transport Act 22 of 1999
Road Traffic and Transport Regulations, 2001

[heading of regulation 42 substituted by GN 104/2007]

- 43. Annual renewal of motor vehicle licence
- 43A. Electronic renewal of motor vehicle licence
 [regulation 43A inserted by GN 298/2021]
- 44. Additional requirements for application for licensing in the case of alteration or reconstruction of registered motor vehicle
- 45. Procedure on change of appropriate registering authority due to owner moving
- 46. Procedure on redefining of area of registering authority
- 47. Procedure on change of licence mark of registering authority or licence number system
- 48. Display of licence number
- 49. Distinguishing sign in terms of Convention
- 50. Display of licence disc
- 51. Procedure for refund of motor vehicle licence fees

PART 3
MOTOR TRADE NUMBER

- 52. Motor vehicle may be operated under motor trade number under certain circumstances
- 53. Manner of application for motor trade number
- 53A. Motor trade number system
 [regulation 53A inserted by GN 86/2017]
- 54. Manner of issue of motor trade number
- 55. Motor trade number to be licensed
- 56. Date on which motor trade number to be licensed
- 57. Manner of application for licensing of motor trade number
- 58. Manner of licensing of motor trade number
- 59. Period of validity of motor trade number licence and motor trade number licence disc
- 60. Annual renewal of motor trade number licence
- 61. Procedure for change of particulars of holder of motor trade number
- 62. Cancellation of motor trade number
- 63. Number issued in any country
- 64. Display of motor trade number and motor trade number licence disc
- 65. Right of appeal to Minister

PART 4
TEMPORARY AND SPECIAL PERMITS

- 66. Circumstances in which motor vehicle may be operated on public road under temporary or special permit
- 67. Manner of application for temporary or special permit
- 68. Temporary or special permit number system
- 69. Manner of issue of temporary or special permit
- 70. Period of validity of temporary and special permit
- 71. Display of temporary or special permit
- 72. Duty of motor dealer in respect of temporary permit

PART 5
**REGISTRATION OF MANUFACTURERS, BUILDERS IMPORTERS AND
 NUMBER PLATE MANUFACTURERS**

- 73. Manner of application for registration of manufacturer, builder or importer
- 74. Manner of registration of manufacturer, builder or importer

REGULATIONS
Road Traffic and Transport Act 22 of 1999
Road Traffic and Transport Regulations, 2001

75. Conditions upon which manufacturer, builder or importer may be registered
76. Manner of suspension or cancellation of registration of manufacturer, builder or importer
77. Number plate manufacturer must register
78. Manner of application for and registration of number plate manufacturer
79. Conditions for registration as number plate manufacturer
80. Manner of suspension or cancellation of registration of number plate manufacturer
81. Duties of manufacturer, builder or importer who are not required to register
82. Power and duties of the inspectorate of manufacturers, builders, importers and number plate manufacturers
83. Fee to defray expenditure incurred by the inspectorate of manufacturers, builders, Importers and number plate manufacturers
84. Procedure for change of particulars of manufacturer, builder, importer or number plate manufacturer
85. Manner of change of conditions on which manufacturer, builder, importer or number plate manufacturer is registered

PART 6
GENERAL

86. Procedure for change of particulars of title-holder or owner of registered motor vehicle
87. Duty of title-holder and owner of motor vehicle where that title-holder or owner changes
88. Procedure in case of dispute in relation to appropriate registering authority
89. Procedure if motor vehicle is stolen
90. Procedure if motor vehicle becomes permanently unfit for use as motor vehicle
91. Number to be affixed to motor vehicle
92. Penalties for late registration or licensing
93. Vehicles exempt from payment of registration and licence fees
94. Arrear fees for licensing of motor vehicle or motor trade number
95. Period of grace
96. Procedure when cheque is dishonoured
97. Duty to furnish information
98. Duty of registering authority in respect of records
99. Application for information certificate in respect of motor vehicle
100. Exporting of motor vehicle
101. Manner in which mass measuring certificate to be obtained

CHAPTER 4
FITNESS OF DRIVERS

PART 1
DRIVING TESTING CENTRES

102. Manner of application for registration as driving testing centre and identification of management representative
103. Requirements for registration of driving testing centre
104. Manner of registration of driving testing centre
105. Change of registration particulars
106. Grades of driving testing centres
107. Powers and duties of inspectorate of driving testing centres
108. Manner of suspension or cancellation of registration of driving testing centre
109. Fee to defray expenditure incurred by inspectorate of driving testing centres

PART 2
LEARNERS' AND DRIVING LICENCES

REGULATIONS
Road Traffic and Transport Act 22 of 1999
Road Traffic and Transport Regulations, 2001

110. Categories of learners' licences and driving licences, classes of motor vehicles and age restrictions relating to each category of licence
111. Period of validity of learner's licence, driving licence and professional authorisation
[heading of regulation 111 substituted by GN 163/2002]
112. Defective vision disqualifying person from obtaining or holding licence to drive motor vehicle
113. Manner of application for learner's licence
114. Procedure of test for a learner's licence
[heading of regulation 114 substituted by GN 163/2002]
115. Manner of issue of learner's licence and reinstatement of suspended learner's licence
[heading of regulation 115 substituted by GN 163/2002]
116. Manner of application for driving licence and for renewal thereof
117. Examination and testing for driving licence or renewal thereof
[heading of regulation 117 substituted by GN 163/2002]
118. Manner of issue of driving licence
119. Authorisation to allow person to receive licence card on behalf of another person
120. Manner of application for issue of duplicate learner's or driving licence
[heading of regulation 120 substituted by GN 32/2005]
121. Conditions for acknowledgement and exchange of foreign driving licence and international driving permit
122. Authorisation which serves as licence in terms of section 31 of the Act
123. Application and issue of temporary driving licence
124. Replacement of driving licence under section 40 of the Act
[heading of regulation 124 substituted by GN 163/2002]
125. Change of particulars
126. Manner of application for and issue of driving licence free of endorsement
127. Professional authorisation in terms of section 33(c) of the Act pertaining to certain categories of driving licences
128. Application for and renewal of professional authorisation
[heading of regulation 128 substituted by GN 163/2002]
129. Conditions governing professional authorisation in relation to driving licence
130. Endorsement of licence to reflect professional authorisation
131. Appeal
132. Suspension or cancellation of professional authorisation
133. Prohibition in relation to professional authorisation
134. Circumstances under which motor vehicle presumed to be motor vehicle conveying persons for reward
135. Voidness of professional authorisation
- 135A. Procedure for reinstatement of licence
[regulation 135A inserted by GN 163/2002]
136. Manner of application to cancel or amend endorsement on licence
137. Manner of application for a licence free of endorsements by Court
138. Competence and grading qualifications for instructors
139. Manner of application for instructor's certificate
140. Manner of issue of instructor's certificate
141. Expiry and suspension or cancellation of instructor's certificate
142. Instructor's certificate to be carried on person of instructor
143. Appeal

CHAPTER 5
FITNESS OF VEHICLES

PART 1

REGULATIONS
Road Traffic and Transport Act 22 of 1999
Road Traffic and Transport Regulations, 2001

VEHICLE TESTING STATIONS

144. Manner of application for registration as vehicle testing station
145. Requirements for registration of vehicle testing station
146. Manner of registration of vehicle testing station
147. Change of registration particulars
148. Manner of grading of testing station
149. Terms and conditions of provisional registration and grading of vehicle testing station
150. Manner of suspension or cancellation of registration of testing station
151. Powers and duties of inspectorate of vehicle testing stations
152. Fee to defray expenditure incurred by inspectorate of vehicle testing stations

PART 2
ROADWORTHY CERTIFICATES

153. Roadworthy certificate required in certain circumstances
154. Manner of application for roadworthy certificate
155. Examination and testing of motor vehicle for roadworthiness
156. Manner of certification of roadworthiness
157. Issue of roadworthy certificate
[heading of regulation 157 substituted by GN 205/2004]
158. Issue of roadworthy certificate
[heading of regulation 158 substituted by GN 205/2004]
159. Voidness of roadworthy certificate
160. Period of validity of roadworthy certificate
161.
[regulation 161 deleted by GN 205/2004]
162. Right of appeal to the Commission
163. Notice to direct that motor vehicle be taken to vehicle testing station
164. Procedure after issue of notice in terms of regulation 163

PART 3
EQUIPMENT ON OR IN RESPECT OF VEHICLES

165. Brakes on motor vehicle other than motorcycle or trailer
166. Brakes on motorcycle
167. Brakes on trailers
168. Brakes on pedal cycles
169. Brakes on unspecified vehicles
170. Specifications for brakes
171. Braking performance of service, emergency and parking brakes
172. Condition and operation of brakes
173. Vehicles to be equipped with certain lamps and times when certain lamps must be switched on
174. Visibility distance of lights
175. Headlamps
176. Main beam
177. Dipped beam
178. Daytime running lamp
179. Lights to be displayed on stationery or parked motor vehicle
180. Fog lamps
181. Parking lamps
182. When parking lamps are to be kept lighted

REGULATIONS
Road Traffic and Transport Act 22 of 1999
Road Traffic and Transport Regulations, 2001

183. Front position lamps
184. End-outline-marker lamps
185. Rear lamps
186. Stop lamp
187. Number plate lamp
188. Side marker lamps
189. Interior lamp
190. Lamp illuminating notice on motor vehicle
191. Decorating lamp
192. Reversing lamp
193. Inspection lamps
194. Identification lamps
195. Use of spot lamp
196. Lamps on pedal cycle
197. Lamps on animal-drawn vehicles
198. Lamps on unspecified vehicles
199. Colour of lights
200. Certain lamps to emit diffused lights
201. Lamps to emit steady light
202. Manner in which lamps are to be fitted and maintained
203. Lamps not prescribed or authorised, are prohibited
204. White retro-reflectors to be fitted on front of certain vehicles
205. Red retro-reflectors to be fitted on rear of certain motor vehicles
206. Yellow retro-reflectors to be fitted on sides of certain motor vehicles
207. General requirements for retro-reflectors
208. Rear retro-reflectors on vehicles with certain body
209. Warning sign on rear of certain motor vehicles (chevrons)
210. Unlawful use of reflector or reflective material
211. Side and rear retro-reflective material to be fitted to vehicles (contour markings)
[heading of regulation 211 substituted by GN 188/2006]
212. Motor vehicle to be equipped with direction indicators
213. Direction indicators of flashing type
214. Direction indicator of illuminated window type
215. Combination of different types of direction indicators
216. Direction indicators on motor vehicles with an overall length in excess of seven comma six metres
217. General requirements for direction indicators
218. Prohibition against use of direction indicator not complying with regulations
219. Steering mechanism
220. Sounding devices
221. Glass of windscreen, window and partitions
222. Windscreen wiper
223. Unobstructed driver's view
224. Fuel tank, electrical wiring and battery
225. Engine of motor vehicle to be covered
226. Compulsory wearing of protective helmet in respect of motorcycle and pedal cycle
227. Manner in which side-car is to be attached to motorcycle
228. Exhaust silencers and exhaust pipes
229. Entrance and exits
230. Motor vehicle to be capable of travelling in reverse and forwards
231. Tyres
232. Seatbelts
233. Emergency warning signs (Triangle)

REGULATIONS
Road Traffic and Transport Act 22 of 1999
Road Traffic and Transport Regulations, 2001

- 234. Speedometers
- 235. Motor vehicles operated on a public road to comply with compulsory vehicle specifications
- 236. Wheel flaps
- 237. Rear underrun protection device
- 238. Axle or axle unit to be fitted to semi-trailer
- 239. Certain vehicles exempt from certain regulations of this Part

PART 4
DIMENSIONS OF VEHICLES

- 240. Overall length of vehicle
- 241. Restriction on combination of motor vehicles
- 242. Overall width of vehicle
- 243. Overall height of vehicle and load
- 244. Turning radius and wheelbase
- 245. Overhang of vehicle
- 246. Projections in case of vehicle other than motorcycle or pedal cycle
- 247. Projections in case of motorcycle or pedal cycle
- 248. Warning in respect of projection load
- 249. Certain vehicles exempt from certain regulations of this Part

PART 5
LOADS ON VEHICLES

- 250. Manner in which children are to be counted for the purpose of these regulations
- 251. Mass of person and luggage for determining mass of load
- 252. Number of persons that may be carried on vehicle in relation to seating capacity
- 253. Permissible maximum axle mass load of a vehicle
- 254. Permissible maximum axle unit mass load of a vehicle
- 255. Permissible maximum vehicle mass
- 256. Permissible maximum combination mass
- 257. Load on tyres
- 258. Gross vehicle mass, gross axle massload, gross axle unit massload, gross combination mass, power/mass ratio and axle massload of driving axle/total mass ratio not to be exceeded
- 259. Mass load carrying capacity of the road
- 260. Mass load carrying capacity of bridges
- 261. Distribution of axle mass load and wheel mass load on vehicle fitted with pneumatic tyres
- 262. Axle mass load of vehicles fitted with tyres other than pneumatic tyres
- 263. Information to be displayed on certain vehicles
- 264. Information plates on certain vehicles
- 265. Manner in which goods to be carried
- 266. Carrying of persons on goods vehicle
[heading of regulation 266 substituted by GN 156/2015]
- 267. Presumptions
- 268. Certain vehicles exempt from certain regulations of this Part.

PART 6
PROVISIONS RELATING TO PASSENGER CARRYING VEHICLES

- 269. Persons not to be carried in goods compartment for reward
- 270. Sides and roof
- 271. Entrances, exists and emergency exists of minibuses and buses

REGULATIONS
Road Traffic and Transport Act 22 of 1999
Road Traffic and Transport Regulations, 2001

[The word “exits” is misspelt in the *Government Gazette*, as reproduced above.
It is spelt correctly in the heading in the main body of the text below.]

- 272. Entrances and exists to be fitted with doors
- 273. Stairs
- 274. Passageways
- 275. Seats
- 276. Goods carried on minibus or bus conveying persons for reward
- 277. Windows and windscreens
- 278. Fuel tanks, receptacles and pipes
- 279. Fire extinguishers
- 280. Rear-view mirrors
- 281. Tilt angle
- 282. Standing persons
- 283. Special provisions relating to school buses

CHAPTER 6
MATTERS RELATING TO THE FITNESS OF OPERATORS

PART 1
OPERATOR REGISTRATION

- 284. Classes of motor vehicles in respect of which an operator must be identified and registered
- 285. Categories of operator cards
- 286. Manner of registration of operator and issuing of operator card
- 287. Application for and issue of duplicate operator card
- 288. Change of particulars
- 289. Procedure in case of suspension
- 290. Manner in which operator card is to be displayed on motor vehicle
- 291. Power of Minister

PART 2
DRIVING HOURS

- 292. Drivers to comply with driving hours
- 293. Time limits
- 294. Recording device to measure driving time
- 295. Use of recording advice
- 296. Duties of operator with regard to maintenance and preservation of records produced by recording device
- 297. Records
- 298. Presumption
- 299. Exemptions

PART 3
CROSS-BORDER ROAD TRANSPORTATION

- 300. Manner of application for cross-border permit
- 301. Manner of issue of cross-border permit
- 302. Period of validity of cross-border permit
- 303. Application for and issue of duplicate cross-border permit

PART 4
TRANSPORTATION OF DANGEROUS GOODS

REGULATIONS
Road Traffic and Transport Act 22 of 1999
Road Traffic and Transport Regulations, 2001

- 304. Definitions for dangerous goods
- 305. Application
- 306. Limitation on transportation of dangerous goods
- 307. Exemptions
- 308. Duties of operator, driver, consignor and consignee
- 309. Dangerous goods to be compatible
- 310. Authority for classification of dangerous goods
- 311. Driver to undergo training
- 312. Documents to be held by driver
- 313. Dangerous goods inspectors
- 314. Powers, duties and functions of dangerous goods inspectors

CHAPTER 7
ROAD TRAFFIC SIGNS AND SPEED LIMITS

PART 1
ROAD TRAFFIC SIGNS

- 315. Purpose, classification and types of road traffic signs
- 316. Dimensions for manufacture of road traffic signs
- 317. Colours for manufacture of road traffic signs
- 318. Manner of display of road signs and road signals
- 319. Signs regulating parking, stopping and hawkers prohibited
- 320. Authority to enter premises contrary to regulatory sign
- 321. Prohibition on advertising material on or attached to road traffic sign or used in advertisement
- 322. Transitional provisions relating to colours of road traffic signs

PART 2
SPEED LIMITS

- 323. General speed limits
- 323A. Prohibition on speed detectors, jammers and similar devices
[regulation 323A inserted by GN 81/2010]
- 324. Speed limit for particular class of vehicle
- 325. Speed limit in relation to tyres
- 326. Speed limited in relation to braking capability
- 326A. Speed measuring instrument
[regulation 326A inserted by GN 156/2015;
 heading substituted by GN 130/2018]

CHAPTER 8
MATTERS RELATING TO THE RULES OF THE ROAD

PART 1
RULES OF THE ROAD

- 327. Vehicle to be driven on left side of roadway
- 328. Driving on divided public road
- 329. Passing the vehicle
- 330. Prohibition on driving on shoulder of public road
- 331. Crossing or entering public road or traffic lane

REGULATIONS
Road Traffic and Transport Act 22 of 1999
Road Traffic and Transport Regulations, 2001

- 332. Driving signals
- 333. Right of way at certain road junctions
- 333A. Right of way for funeral vehicular procession
[regulation 333A inserted by GN 188/2006]
- 334. Procedure when turning
- 335. Towing of vehicles
- 336. Stopping of vehicles
- 337. Stopping of vehicle for State motorcade
- 338. Parking of vehicles
- 339. Certain vehicles may be stopped and parked at any place where necessary
- 340. Compulsory steps
- 341. General duties of driver or passenger of vehicle on public road
- 342. Prohibition on use of communication device while driving
- 343. Duties relating to motorcycle
- 344. Loud sound amplification system in motor vehicle and motor vehicles causing excessive noise
[heading of regulation 344 substituted by GN 188/2006]
- 345. Use of hooter
- 346. Riding on pedal cycles
- 347. Device running on rails
- 348. Animal on public road
- 349. Animal-drawn vehicles
- 350. Pedestrians' right of way in pedestrian crossing
- 351. Duties of pedestrians
- 352. Racing and sport on public roads
- 353. Convoys on public road
- 354. Hindering or obstructing traffic on public road
- 355. Vehicle left or abandoned on public road
- 356. Damage to public roads
- 357. Trading on public roads
- 358. Special provisions relating to freeways

PART 2
DRIVING SIGNALS AND SIGNALS FOR THE CONTROL OF TRAFFIC

- 359. Use of direction indicator
- 360. Left-turn hand signal
- 361. Right-turn hand signal
- 362. Signal to indicate intention to reduce speed
[The word "intention" is misspelt in the *Government Gazette*, as reproduced above. It is spelt correctly in the heading in the main body of the text below.]
- 363. Permissible hand signals
- 364. Signals for use by traffic officer for control of traffic

PART 3
GENERAL

- 365. Towing of vehicles

CHAPTER 9
MISCELLANEOUS

- 366. Matters relating to registers and records

REGULATIONS
Road Traffic and Transport Act 22 of 1999
Road Traffic and Transport Regulations, 2001

- 367. Vintage motor vehicles
- 368. Seizure
- 369. Offences and penalties
- 370. Apportionment of fees
- 371. Licences inspector, traffic officer or road transport inspector entitled to free use of certain facilities
- 372. Officer to use approved forms
- 373. Application for and issue of traffic register number and certificate
- 374. Proxy
- 375. Prohibition against the use of certain lamps or lighting devices
- 376. Standard publications incorporated in terms of section 94 of Act
- 377. Persons having access to registers to be registered
- 378. Appeal procedure
- 379. Procedure for hearings

CHAPTER 10
TRANSITIONAL PROVISIONS

- 380. Schedule to regulate certain matters
- 381. Presumption with regard to Schedule
- 382. Title-holder and owner same person
- 383. Period of validity of driving licence for transitional period
[Regulation 383 is deleted by GN 97/2001 and inserted by GN 163/2002]
- 383A. Interim Procedure for the exchange of a driving licence contained in South African identity document
[Regulation 383A is inserted by GN 103/2002.
The word "procedure" in the heading should not be capitalised.]
- 383A. Transitional provision in relation to public driving permit
[A second regulation 383A is inserted by GN 163/2002.]
- 384. Owner deemed to be operator
- 385. Inspectorates
- 386. Authorised officers and authorised users
- 387. Short title

SCHEDULE 1
MISCELLANEOUS FEES

- 1. Fees

SCHEDULE 2
ROAD TRAFFIC SIGNS

- 1. Road Traffic Signs

SCHEDULE 3
[Schedule 3 is deleted by GN 86/2017.]

SCHEDULE 4
[Schedule 4 is amended by GN 97/2001 and GN 103/2002, and deleted by GN 163/2002.]

SCHEDULE 5
[Schedule 5 is amended by GN 163/2002 and GN 163/2002, and deleted by GN 2/2008.]

SCHEDULE 6

REGULATIONS
Road Traffic and Transport Act 22 of 1999
Road Traffic and Transport Regulations, 2001

[Schedule 6 is deleted by GN 2/2008.]

[GN 205/2004 directs the substitution of the words “Banking Institutions Act, 1998” for the words “Banks Act, 1965” throughout the regulations. However, the phrase “Banks Act, 1965” does not appear in the regulations. In any event, the Banking Institutions Act 2 of 1998 has been replaced by the Banking Institutions Act 13 of 2023.]

The regulations use the following interchangeably: “motorcycle” and “motor cycle”, “one-way” and “one way”, “right-hand” / “left-hand” and “right hand” / “left hand” and “side-car” and “side car”.]

CHAPTER 1

Definitions

1. In these regulations, unless the context otherwise indicates, any expression to which a meaning has been assigned in the Act, has, when used in these regulations, the meaning thus assigned, and -

“acceptable identification” means -

- (a) an identity document issued in terms of the Identification Act, 1996 (Act No. 21 of 1996);
- (b) in the case of a person not permanently resident in Namibia, an identity document issued by a foreign country or a traffic register number certificate issued in terms of regulation 373;
- (c) in the case of -
 - (i) a company, a certificate of incorporation or name change issued in terms of the Companies Act, 1973 (Act No. 61 of 1973); or

[The Companies Act 61 of 1973 has been replaced by the Companies Act 28 of 2004.]
 - (ii) a close corporation, a founding statement or a certificate of name change issued in terms of the Close Corporations Act, 1988 (Act No. 26 of 1988);
- (d) in the case of -
 - (i) a person carrying on a business including farming activities;
 - (ii) a body of persons not referred to in paragraph (c); or
 - (iii) a Namibian citizen or a person who holds a permanent residence permit issued in terms of the Immigration Control Act, 1993 (Act No. 7 of 1993) and who does not have a valid identity document issued in terms of the Identification Act, 1996 (Act No. 21 of 1996), a traffic register number certificate;

a traffic register number certificate issued in terms of regulation 373;

REGULATIONS
Road Traffic and Transport Act 22 of 1999
Road Traffic and Transport Regulations, 2001

- (e) a driving licence card issued in terms of regulation 118; or
- (f) except for the purposes of regulations 113, 115, 116, 118, 120 and 121, a certified copy of the certificate or document referred to in paragraphs (a), (b), (c) or (d);

[definition of “acceptable identification” amended by
GN 163/2002 and substituted by GN 188/2006]

“**adaptor dolly**” means a semi-trailer with one or more axles, designed or adapted -

- (a) to be attached between a truck-tractor and semi-trailer; and
- (b) not to carry any load other than that imposed by a semi-trailer;

“**appropriate registering authority**” means -

- (a) subject to paragraphs (b), (c) and (d) in relation to any matter referred to in these regulations -
 - (i) in relation to a person, the registering authority in whose area such person permanently resides;
 - (ii) in relation to a person carrying on a business, which for the purposes of these regulations includes farming activities, the registering authority in whose area such business is situated, and every branch of that business is deemed to be a separate business;
 - (iii) in relation to a body of persons which has a fixed address, the registering authority in whose area such address is, and every branch of such body is deemed to be a separate body of persons; or
 - (iv) in relation to a body of persons which does not have a fixed address, the registering authority in whose area the proxy or representative of such body permanently resides, and every branch of such body is deemed to be a separate body of persons;
- (b) in relation to the registration of a motor vehicle -
 - (i) subject to subparagraphs (ii), (iii), (iv) and (v), the appropriate registering authority of the title-holder;
 - (ii) if the manufacturer, builder or importer of that motor vehicle has been appointed as an agent of a registering authority, that manufacturer, builder or importer, until a registration certificate has been issued in respect of such motor vehicle;
 - (iii) of which the title-holder is a Government ministry which has been appointed as a registering authority, that Government ministry;
 - (iv) of which the title-holder is a foreign government, diplomat representing a foreign country, international or intergovernmental organisation or any

REGULATIONS
Road Traffic and Transport Act 22 of 1999
Road Traffic and Transport Regulations, 2001

person or class of persons as the Minister responsible for Foreign Affairs may determine, the Ministry responsible for Foreign Affairs; or

- (v) of which the title-holder does not permanently reside in Namibia, the registering authority referred to in paragraph (e);
- (c) in relation to the licensing of a motor vehicle -
 - (i) subject to subparagraphs (ii) and (iii), the appropriate registering authority of the owner;
 - (ii) of which the owner is a Government ministry which has been appointed as a registering authority, that Government ministry; or
 - (iii) of which the owner is a foreign government, diplomat representing a foreign country, international or intergovernmental organisation or any person or class of persons as the Minister responsible for Foreign Affairs may determine, the Ministry responsible for Foreign Affairs;
- (d) in relation to any other matter and in any circumstances not provided for in the foregoing, the registering authority nominated by the Minister;

“approval mark” means -

- (a) the approval mark of the Economic Commission for Europe denoted by the mark ‘E’;
- (b) the approval mark of the European Economic Committee denoted by the mark ‘c’; or
- (c) any other approval mark referred to in a specification, code of practice or any directive having standardisation as its aim, and issued by a national institution or organization outside Namibia for a purpose similar to that for which a certification mark has been established;

“approved” means approved by the Minister;

“articulated motor vehicle” means a combination of motor vehicles consisting of a truck-tractor and a semi-trailer;

“axle” in relation to a vehicle, means a device or set of devices, whether continuous across the width of the vehicle or not, about which the wheels of the vehicle rotate and which is so placed that, when the vehicle is travelling straight ahead, the vertical centre-lines of such wheels would be in one vertical plane at right angles to the longitudinal centre-line of such vehicle;

“axle massload” means the sum of the wheel mass load of all wheels on any axle;

“axle unit” in relation to a vehicle, means -

- (a) a set of two or more parallel axles of such vehicle which are so interconnected as to form a unit; or

REGULATIONS
Road Traffic and Transport Act 22 of 1999
Road Traffic and Transport Regulations, 2001

- (b) for the purpose of the definition “wheelbase” and Parts 3 and 4 of Chapter 5, in the case of a trailer, two or more axles, whether interconnected or not, where the distance between adjacent axles is less than one comma two meters.

[The definition of “axle unit” is substituted by GN 98/2016.
 The term being defined is not bolded in the substituted definition,
 although it was in the original definition. It has been bolded here for consistency.]

“**Banking Institutions Act, 1998**” means the Banking Institutions Act, 1998 (Act No. 2 of 1998);

[The definition of “Banking Institutions Act, 1998” is substituted for the definition of “Banks Act, 1965” by GN 205/2004. However, neither phrase appears elsewhere in the regulations as originally enacted or as amended. In any event, the Banking Institutions Act 2 of 1998 has been replaced by the Banking Institutions Act 13 of 2023.]

“**body of persons**” in relation to the title-holder or owner of a motor vehicle, means a body of persons whether a body corporate or not, and includes -

- (a) two or more persons who are joint title-holders or owners of such motor vehicle, but excluding joint title-holders or owners who are husband and wife married in community of property; and
- (b) a Government ministry;

“**breakdown vehicle**” means a motor vehicle designed or adapted solely or principally for the purpose of recovering or salvaging motor vehicles and which is registered as a breakdown vehicle;

“**bus**” means a motor vehicle designed or adapted for the conveyance of more than 16 persons (including the driver, if any);

“**bus-train**” means a bus which -

- (a) consists of two sections connected to form a unit;
- (b) can swivel in a horizontal plane at the connection between such sections;
- (c) is designed or adapted solely or principally for the conveyance of the driver and at least 100 other persons; and
- (d) has a continuous passageway over the length thereof;

“**centre-line of an axle unit**” or any like expression, means a line midway between the centre-lines of the extreme axles of an axle unit;

“**certification mark**” means a mark or an approval that has been established in respect of a standard specification certification;

[The definition of “certification mark” is substituted by GN 188/2006. The term being defined has been shown in bold like the other terms defined in the regulations, even though it is not in boldface type in the *Government Gazette*.]

“**Convention**” means -

REGULATIONS
Road Traffic and Transport Act 22 of 1999
Road Traffic and Transport Regulations, 2001

- (a) the International Convention relative to Motor Traffic (Paris, 1926);
- (b) the United Nations Convention on Road Traffic (Geneva, 1949);
- (c) the United Nations Convention on Road Traffic (Vienna, 1968); or
- (d) any subsequent related convention ratified by the Government of Namibia;

“converter dolly” means a trailer which has one or more axles and, when used in combination with a semi-trailer, converts the semi-trailer into a trailer;

“cross” or any like expression, means to move on a public road in a direction which intersects the normal course of travel of traffic on such road;

“direction indicator” means a device fitted to a motor vehicle for the purpose of enabling the driver of the motor vehicle to intimate his or her intention to change the direction of travel of that motor vehicle to the right or to the left;

“driving licence card” means a driving licence card issued in terms of regulation 118;

“emergency brake” means a brake, excluding a service brake, which can stop a vehicle;

“fog lamp” means a lamp which, when used during conditions of mist, snow, rainstorms or sandstorms and -

- (a) when fitted to the front of a motor vehicle, improves the illumination of the road; and
- (b) when fitted to the rear of a motor vehicle, signals to other traffic the position, orientation and movement of the motor vehicle,

without producing undue glare to other traffic;

[definition of “fog lamp” inserted by GN 205/2004]

“front end”, in relation to -

- (a) a vehicle, excluding a semi-trailer, means that part of the vehicle which projects furthest forward; or
- (b) a semi-trailer, means a line running parallel with the centre-line of the king-pin and connecting the sides of the semi-trailer at the widest and furthest point in front of the king-pin;

“front overhang”, in relation to a vehicle, means that part of the vehicle, excluding any drawbar or coupling, which projects in front of the centre-line of the front axle or the foremost axle of the front axle unit or, if that vehicle has only one axle, which projects in front of the centre-line of that axle, or in the case of a semi-trailer, which projects in front of the centre line of the kingpin, but any part of a semi-trailer which projects in front of its front end or anything attached to a semi-trailer in front of its front end and which is within an area formed by drawing, with the kingpin as centre, an arc connecting the extreme points of the front end of the semi-trailer, is not considered to be part of the front overhang of that semi-trailer;

REGULATIONS
Road Traffic and Transport Act 22 of 1999
Road Traffic and Transport Regulations, 2001

“**goods vehicle**” means a motor vehicle excluding a motorcycle, motor car, minibus or bus, designed or adapted for the conveyance of goods on a public road and includes a truck-tractor, adaptor dolly, converter dolly and breakdown vehicle;

“**gross axle massload**”, in relation to a motor vehicle, means the maximum massload of a particular axle of the vehicle as specified by the manufacturer thereof or, in the absence of such specification, as determined by the registering authority;

“**gross axle unit massload**”, in relation to a motor vehicle, means the maximum massload of a particular axle unit of the vehicle as specified by the manufacturer thereof or, in the absence of such specification, as determined by the registering authority;

“**gross combination mass**”, in relation to a motor vehicle which is used to draw any other motor vehicle, means the maximum mass of any combination of motor vehicles, including the drawing vehicle, and load as specified by the manufacturer thereof or, in the absence of such specification, as determined by the registering authority;

“**gross kingpin massload**”, in relation to a semi-trailer, means the maximum massload of the kingpin as specified by the manufacturer of the semi-trailer or in the absence of such specification, as determined by the registering authority;

“**intersection**” means the area embraced within the prolongation of the lateral boundary lines of two or more public roads, open to vehicular traffic, that join one another at any angle, whether or not one such public road crosses the other;

“**issuing authority**” means an issuing authority designated in terms of regulation 39(1);

[definition of “issuing authority” inserted by GN 205/2004,
deleted by GN 45/2005 and re-inserted by GN 104/2007]

“**junction**” means that portion of an intersection contained within the prolongation of the lateral limits of the intersecting roadways and such junction includes any portion of the roadway between such lateral limits, and any stop or yield line marking which is painted at such intersection;

“**licence disc**” means a disc issued in terms of regulation 32;

“**licence number**” means a number as referred to in regulation 34;

“**longitudinal centre-line**”, in relation to a vehicle, means a line midway between the centre-lines of the extreme outer wheels fitted to the axles of that vehicle;

“**minibus**” means a motor vehicle designed or adapted solely or principally for the conveyance of more than nine, but not more than 16 persons, including the driver;

“**modify**” means -

- (a) fitting a bus body or goods body to any chassis;
- (b) altering the number of passenger seats or altering the dimensions of a bus;
- (c) extending or shortening the wheelbase of a vehicle, unless the vehicle is designed to enable the wheelbase to be adjusted; or

REGULATIONS
Road Traffic and Transport Act 22 of 1999
Road Traffic and Transport Regulations, 2001

- (d) altering the axle or axle-unit position or number of axles;

“motor car” means a motor vehicle, excluding a motorcycle, designed or adapted solely or principally for the conveyance of not more than nine persons, including the driver;

“motorcycle” includes -

- (a) a motorcycle having a sidecar attached to it;
- (b) a motor tricycle; and
- (c) a motor quadrucycle;

[definition of “motorcycle” substituted by GN 205/2004]

“motor quadrucycle” means a motor vehicle, excluding a tractor, which has four wheels or more and which is designed to be steered by the type of controls usually fitted to a motorcycle;

“motor trade number” means a motor trade number referred to in regulation 52;

“motor trade number registration certificate” means the certificate referred to in regulation 54;

“motor transport contractor” means a person who carries on a business of delivering motor vehicles of which he or she is not the owner;

“motor tricycle” means a motor vehicle, excluding a motorcycle, motor quadrucycle or a tractor, which has three wheels and which is designed to be steered by the type of controls usually fitted to a motorcycle;

“motor vehicle licence” means a licence referred to in regulation 32;

“number plate” means a plate referred to in regulation 48 on which the licence mark referred to in regulation 34 and the licence number allotted to a motor vehicle upon licensing, is displayed;

“overall height”, in relation to a vehicle, means the distance measured from ground level to the highest part of -

- (a) any part of such vehicle; or
- (b) any load thereon,

whichever part is the highest, but in the case of a vehicle driven by electrical power, the overall height should not include any overhead electrical contacting gear or catwalk protruding above such vehicle;

“overall length”, in relation to a vehicle, means the distance between the front end and the rear end of the vehicle and, in relation to a combination of vehicles, the distance between the front end of the leading vehicle and the rear end of the rearmost vehicle;

REGULATIONS
Road Traffic and Transport Act 22 of 1999
Road Traffic and Transport Regulations, 2001

“overall width”, in relation to a vehicle, means the width measured between two planes parallel to the longitudinal centre-line of the vehicle and passing through the extreme projecting points on either side of that vehicle, excluding any side mirror or direction indicator;

“overrun brake”, in relation to a trailer, means a braking system actuated by a device fitted to the drawbar of the trailer when a force is exerted on that device by reason of the inertia of the trailer;

“parking brake” means a brake, normally a hand brake, used in the ordinary course of events to keep a vehicle stationary;

“Pedestrian crossing” means -

- (a) that portion of a public road at an intersection included within the prolongation or connection of the kerb line and adjacent boundary line of such road, whether such portion is marked or not; or
- (b) any other portion of a public road designated as a pedestrian crossing by appropriate road traffic signs;

[The word “pedestrian” should not be capitalised.]

“pedal cycle” means any bicycle or tricycle designed for propulsion solely by means of human power;

“personalised licence number” means a personalised licence number referred to in regulation 37(1);

[definition of “personalised licence number” inserted by GN 104/2007]

“public driving permit” means a public driving permit issued in terms of the repealed Ordinance;

“police clearance” means a clearance certificate contemplated in section 1 of the Vehicle Theft Act, 1999 (Act No. 12 of 1999);

[The correct name of Act 12 of 1999 is the “Motor Vehicle Theft Act”.]

“rear end”, in relation to a vehicle, means that part of the vehicle which projects furthest to the rear;

“rear overhang”, in relation to a vehicle, means that part of the vehicle which projects to the rear of the centre-line of the rear axle or the rearmost axle of the rear axle unit or, if that vehicle has only one axle, which projects to the rear of the centre-line of that axle;

“reasonably level”, in relation to a road, means a road which does not exceed a plus or minus one per cent grade;

“registration certificate” means a certificate issued to the title-holder of a motor vehicle in terms of regulation 22;

“retro-reflector” means a reflector which complies with the standard specification of the South African Bureau of Standards, SABS 513: 1985 “Retro-reflectors (Reflex Reflectors)”, published

REGULATIONS
Road Traffic and Transport Act 22 of 1999
Road Traffic and Transport Regulations, 2001

by the South African Government Notice 2190 dated 14 June 1986, and which bears a certification mark or approval marks, but where a reflector is incorporated in a cluster of lamps, the approval mark can be on the cluster instead of the reflector;

“**safety glass**” means transparent glass or other transparent material so constructed or treated that, when fractured, the possibility of large flying fragments or sharp splinters is minimised;

“**school bus**” means a bus or minibus owned by or contracted to a school and used principally for the conveyance of school children and other persons associated with that school;

“**selective restriction sign**” means a regulatory sign which comprises of a two part message which is such that the lower message modifies or qualifies the significance of the upper message;

[The word “of” after the word “comprises” is superfluous.]

“**semi-trailer**” means a trailer having no front axle and so designed that at least 15 per cent of its tare is super-imposed on and borne by a vehicle drawing such trailer;

“**service brake**” means a brake, normally a footbrake, used in the ordinary course of events to reduce the speed of a vehicle or to stop the vehicle and which consists of -

- (a) a single braking system which brakes the front and rear wheels of the vehicle simultaneously or, in the case of -
 - (i) a semi-trailer, brakes the wheels thereof simultaneously;
 - (ii) a trailer, which according to the registration certificate thereof, was registered for the first time before 1 January 1983 and which is not a semi-trailer, brakes the front or rear wheels or all wheels thereof simultaneously; or
 - (iii) a tractor, brakes the wheels of the rear axle or rear axle unit of the tractor simultaneously; or
- (b) two braking systems which -
 - (i) jointly brake the front and rear wheels of the vehicle simultaneously; and
 - (ii) independently brake at least two wheels of the vehicle simultaneously;

“**special permit**” means a permit referred to in regulation 66(1)(b);

“**speed detectors or jammers**” means any device used for detecting the use, or preventing the effective use, of a speed measuring device;

[definition of “speed detectors or jammers” inserted by GN 81/2010]

“**State motorcade**” means a motor vehicle or a group of motor vehicles traveling together for the purposes of conveying Namibian or foreign state dignitaries and escorted by traffic officers or military police to ensure a safe and unimpeded journey for the motor vehicle or motor vehicles;

[The definition of “State motorcade” is substituted by GN 188/2006. The term being defined has been shown in bold like the other terms defined in the regulations, even though it is not in boldface type in the *Government Gazette*.]

REGULATIONS
Road Traffic and Transport Act 22 of 1999
Road Traffic and Transport Regulations, 2001

“**steering axle**” means an axle, the wheels of which are attached in such a manner that it enables the vehicle concerned to be steered thereby, but excludes -

- (a) any axle of a semitrailer or trailer;
- (b) the rear axle or axles of any motor vehicle; and
- (c) any axle of a motor vehicle which is steered by movement of the front part of the vehicle relative to the rear part of the vehicle, or which is steered by movement of its articulated frame,

and the phrase “steering axle unit” has the same meaning subject to due alteration where necessary;

“**stop lamp**” means a device fitted to a vehicle for the purpose of signalling, by means of a light, the intention of the driver of that vehicle to stop or reduce the speed of that vehicle;

“**temporary permit**” means a permit referred to in regulation 66(1)(a);

“**the Act**” means the Road Traffic and Transport Act, 1999 (Act No. 22 of 1999);

[definition of “the Standards Act, 1993” deleted by GN 188/2006]

“**tractor**” means a motor vehicle designed or adapted solely or principally for drawing other vehicles and not to carry any load thereon, but does not include a truck-tractor;

“**traffic island**” means a physical island that serves as a channelling device within a junction or on a public road;

“**traffic register number**” means a number allocated in terms of regulation 373;

“**traffic register number certificate**” means a certificate issued in terms of regulation 373;

“**traffic signal**” means a road traffic sign which, by means of automatic light signals, alternately directs traffic to stop and permits it to proceed;

“**truck-tractor**” means a motor vehicle designed or adapted -

- (a) for drawing other vehicles; and
- (b) not to carry any load other than that imposed by a semi-trailer or by ballast,

but does not include a tractor;

“**turning radius**”, in relation to a vehicle, means the radius of the circle described by the outer steerable wheel of a vehicle when such wheel is deflected as far as possible from the straight, either to the left or to the right, and, where the radius so obtained are not the same, the larger of the two is taken as the turning radius of the vehicle, the radius being measured to the outer edge of the track described by such outer steered wheel;

“**vintage motor vehicle**”, in relation to provisions relating to roadworthiness, means a motor vehicle manufactured before 1965;

REGULATIONS
Road Traffic and Transport Act 22 of 1999
Road Traffic and Transport Regulations, 2001

“wheel-base” -

- (a) in relation to a semi-trailer, means the distance measured at ground level between parallel planes at right-angles to the longitudinal centre-line of the vehicle passing through the centre-line of its kingpin and the centre-line of its axle or axle unit, as the case may be;
- (b) in relation to a trailer with only one axle or one axle unit, excluding a semi-trailer, means the distance, measured at ground level, between parallel planes at right angles to the longitudinal centre-line of the vehicle passing through the centre-line of the coupling pin or knuckle and the centre-line of such axle or axle unit, as the case may be; and
- (c) in relation to any other vehicle, means the distance measured at ground level, between parallel planes at right-angles to the longitudinal centre-line of the vehicle passing through the centre-line of the front axle or front axle unit and the centre-line of the rear axle or rear axle unit, as the case may be; and

“wheel massload”, in relation to any wheel of a vehicle, means the total mass supported by the contact area between the tyre of that wheel and the road surface.

CHAPTER 2
AUTHORISED OFFICERS

Registration of authorised officers

2. An authorised officer appointed in terms of section 11 of the Act, may not perform the duties and functions of an authorised officer unless he or she is registered in a category contemplated in that section.

Qualifications for authorised officers

3. An authorised officer may not be registered in any category contemplated in section 11 of the Act unless he or she has obtained, after completion of the required training, an appropriate qualification for that category of authorised officer from an approved training centre.

Manner of application for registration in category of authorised officer

4. An application for registration in any category of authorised officer must be made to the Minister on the approved form and must be accompanied by acceptable identification of the applicant and a certified copy of any document, certificate or diploma relating to the applicant’s competence and registration requirements as contemplated in regulation 5 contemplated in Schedule 1.

[Regulation 4 is amended by GN 98/2016. It directs the deletion of the phrase “and the appropriate fees” (plural), which did not appear in Regulation 4. This direction has been applied to delete the phrase “and the appropriate fee” (singular).]

Requirements for competency and registration to be complied with by applicant to be registered in category of authorised officer

REGULATIONS
Road Traffic and Transport Act 22 of 1999
Road Traffic and Transport Regulations, 2001

5. (1) The requirements for registration in any category of authorised officer are that the applicant -

- (a) has obtained an appropriate training centre; and qualification at an approved training centre; and
 - (b) in the opinion of the Minister, is a fit and proper person to be registered as an authorised officer, but a person appointed in any category as authorised officer in terms of the repealed Ordinance or the Road Transportation Act, 1977 (Act No. 74 of 1977) is deemed to comply with this subregulation, for that particular category.
- (2) The qualification referred to in subregulation (1)(a) must -
- (a) in the case of a vehicle examiner, indicate the classes of motor vehicles he or she is qualified to inspect, examine and test; or
 - (b) in the case of a driving examiner, indicate the codes of learner's licences and driving licences for which a person may be examined and tested by that examiner.

Manner of registration of authorised officers

6. (1) If the Minister is satisfied that an applicant complies with regulation 5, he or she must -

- (a) in the case of a vehicle examiner or driving examiner, grade the applicant in terms of regulation 8;
- (b) record the particulars of the applicant on the register of authorised officers referred to in regulation 366(1)(a)(i); and
- (c) issue to the applicant, on receipt of the appropriate fee contemplated in Schedule 1, a certificate of registration on the approved form.

(2) If an applicant does not comply with regulation 5, the Minister must refuse to register the applicant and notify him or her accordingly.

Change of registration particulars

7. (1) A person registered in terms of regulation 6 must, within 21 days after the change of any of the particulars submitted in terms of regulation 4, notify the Minister of that change on the approved form.

(2) The Minister must, on receipt of a notification referred to in subregulation (1), update the register of authorised officers referred to in regulation 366(1)(a)(i) accordingly.

Grades of vehicle examiners and driving examiners

- 8.** (1) The Minister must grade a vehicle examiner as -
- (a) grade A, if the qualification referred to in regulation 5(1)(a) indicates that such examiner is qualified to examine and test a motor vehicle of any class, but -

REGULATIONS
Road Traffic and Transport Act 22 of 1999
Road Traffic and Transport Regulations, 2001

- (i) a person appointed as an examiner of vehicles in terms of the repealed Ordinance;
 - (ii) who holds a code EC driving licence for a manual transmission or equivalent and a code A driving licence; and
 - (iii) who has obtained a diploma or equivalent qualification in the examination of vehicles; or
 - (iv) who has a minimum of five years experience as an examiner of vehicles, which is acceptable to the Minister, is deemed to comply with this paragraph; or
- (b) grade B, if the qualification referred to in regulation 5(1)(a) indicates that such examiner is qualified to examine and test a motor vehicle of any class, except for a goods vehicle or bus with a gross vehicle mass exceeding 3,500 kilograms, but a person appointed as an examiner of vehicles in terms of the repealed Ordinance and who holds a code E8 driving licence for a manual transmission and a code A driving licence, is deemed to comply with this paragraph.
- (2) A vehicle examiner who is graded in terms of subregulation (1) -
- (a) as a grade A examiner of vehicles, is authorised to inspect, examine and test a motor vehicle or any class: or
 - (b) as a grade B examiner of vehicles, is authorised to inspect, examine and test a motor vehicle of any class, except for a goods vehicle or a bus with a gross vehicle mass exceeding 3 500 kilograms.
- (3) The Minister must grade a driving examiner as -
- (a) grade A, if the qualification referred to in regulation 5(1)(a) indicates that such examiner is qualified to examine and test a person for any code of learner's or driving licence and the examiner holds a code EC driving licence for manual transmission and a code A driving licence;
 - (b) grade B, if the qualification referred to in regulation 5(1)(a) indicates that such examiner is qualified to examine and test a person for a learner's licence of any code and for a driving licence code B, C I, C, EB, EC I and EC and the examiner holds a code EC driving licence for a manual transmission;
 - (c) grade C, if the qualification referred to in regulation 5(1)(a) indicates that such examiner is qualified to examine and test a person for a learner's licence of any code and for driving licence codes A1, A and B and the examiner holds a code EB licence for a manual transmission and a code A driving licence;
 - (d) grade D, if the qualification referred to in regulation 5(1)(a) indicates that such examiner is qualified to examine and test a person for a learner's licence of any code and for a driving licence code B and the examiner holds a code EB driving licence for a manual transmission;

REGULATIONS
Road Traffic and Transport Act 22 of 1999
Road Traffic and Transport Regulations, 2001

- (e) grade F, if such examiner is qualified to the satisfaction of the Minister to substitute a driving licence of any code issued or deemed to have been issued in terms of the repealed Ordinance; or
- (f) grade L, if the qualification referred to in regulation 5(1)(a) indicates that such examiner is qualified to examine and test a person for a learner's licence of any code,

but -

- (i) a person appointed as an examiner for drivers' licences in terms of the repealed Ordinance who holds a code EC driving licence or equivalent, and has -
 - (aa) obtained a diploma or equivalent qualification in the examination for driving licences; or
 - (bb) a minimum of five years experience as an examiner for drivers' licences, which is acceptable to the Minister,
 may be graded in any grade of driving examiner; or
 - (ii) a person appointed as an examiner for drivers' licences in terms of the repealed Ordinance who does not comply with subparagraph (i), must be graded as a grade C, D or L driving examiner, as the case may be.
- (4) A driving examiner who is graded in terms of subregulation (3) -
- (a) as a grade A driving examiner, is authorised to examine and test a person for a learner's licence or driving licence of any code;
 - (b) as a grade B driving examiner, is authorised to examine and test a person for a learner's licence of any code or driving licence of the code B, C1, C, EB, EC1 or EC;
 - (c) as a grade C driving examiner, is authorised to examine and test a person for a learner's licence of any code or driving licence of the code A1, A or B;
 - (d) as a grade D driving examiner, is authorised to examine and test a person for a learner's licence of any code or driving licence of the code B;
 - (e) as a grade F driving examiner, is authorised to substitute a driving licence of any code issued or deemed to have been issued in terms of the repealed Ordinance; or
 - (f) as a grade L driving examiner, is authorised to examine and test a person for any code of learner's licence.

Suspension or revocation of registration of authorised officers

9. (1) The Minister may suspend or revoke the registration of an authorised officer, if the Minister is satisfied that the authorised officer -

REGULATIONS
Road Traffic and Transport Act 22 of 1999
Road Traffic and Transport Regulations, 2001

- (a) has committed an act of misconduct, as set out in subregulation (2), in the exercise of his or her powers or the performance of his or her duties; or
- (b) is incapable of exercising his or her powers or performing his or her duties or is incompetent to exercise his or her powers or to perform his or her duties, as an authorised officer, in the category in which he or she is registered.

(2) An authorised officer commits an act of misconduct if he or she -

- (a) contravenes a term or a condition of his or her registration as an authorised officer;
- (b) without first having obtained the permission to do so, discloses information that is of a confidential nature and which is gained by or conveyed to him or her by virtue of him or her being an authorised officer, except where the disclosure of the information is necessary for the performance of duties of an authorised officer or is required in terms of law.

[The full stop at the end of this paragraph should be a semi-colon.]

- (c) uses, without permission, the facilities and equipment used in connection with his or her duties as an authorised officer for purposes other than for the performance of his or her duties;
- (d) performs any of his or her duties as an authorised officer while under the influence of intoxicating liquor or drugs which adversely affect his or her ability to perform his or her duties as an authorised officer;
- (e) engages himself or herself, without permission, in any activity which conflicts with the performance of his or her duties as an authorised officer;
- (f) commits a criminal offence relating to the performance of his or her duties as an authorised officer;
- (g) refuses, omits or neglects to carry out lawful duties given to him or her in his or her capacity as an authorised officer by any person authorised to do so;
- (h) conducts him or herself in a manner which may reasonably be regarded as improper and dishonourable; or
- (i) contravenes or fails to comply with the Act.

(3) Before revoking or suspending the registration of an authorised officer the Minister must -

- (a) notify the authorised officer concerned of the Minister's intention to suspend or revoke the registration of the authorised officer; and
- (b) request the authorised officer concerned that he or she may, within 14 days of being notified in terms of paragraph (a), make written representations to the Minister.

(4) On receipt of representations, if any, made in terms of subregulation (3)(b), the Minister must consider the representations and may -

REGULATIONS
Road Traffic and Transport Act 22 of 1999
Road Traffic and Transport Regulations, 2001

- (a) if satisfied that the facts relating to the misconduct are sufficiently established, revoke or suspend the registration of an authorised officer; or
 - (b) conduct a hearing in terms of regulation 379.
- (5) If at the expiry of the period referred to in subregulation (3)(b) the Minister has not received any representations the Minister may -
- (a) if satisfied that the facts relating to the misconduct are sufficiently established, revoke or suspend the registration of an authorised officer; or
 - (b) conduct a hearing in terms of regulation 379.
- (6) If a hearing has been conducted in terms of subregulation (4)(b) or (5)(b) the Minister may, on receiving the recommendation of the presiding officer in terms of regulation 379(15), revoke or suspend the registration of an authorised officer.
- (7) When the Minister has revoked or suspended the registration of an authorised officer the Minister must -
- (a) notify the authorised officer concerned of the reasons for the suspension or revocation, and if the Minister has suspended the authorised officer, of the period of suspension; and
 - (b) cause to be updated the register of authorised officers referred to in regulation 366(1)(a)(i) accordingly.
- (8) An authorised officer whose registration has been revoked or suspended must, within 14 days of being notified of the revocation, submit -
- (a) the certificate of registration referred to in regulation 6(1)(c), to the Minister and the Minister may -
 - (i) in the case of a revocation, cancel the registration certificate; or
 - (ii) in the case of a suspension, keep the certificate for the period of suspension; and
 - (b) the certificate of appointment referred to in section 11(8) of the Act to the person who appointed him or her.

[regulation 9 substituted by GN 183/2005]

Appeal procedure

10. (1) An applicant who applied for registration in a category of authorised officer or grading in a particular grade or an authorised officer whose registration has been suspended or revoked, who feels aggrieved by a decision relating to his or her registration or grading or the suspension or revocation of his or her registration, may, within 21 days after the decision, suspension or revocation in writing appeal against that decision, suspension or revocation to the Commission and the appellant must at the same time serve a copy of the appeal on the Minister.

REGULATIONS
Road Traffic and Transport Act 22 of 1999
Road Traffic and Transport Regulations, 2001

(2) After receipt of the copy of the appeal referred to in subregulation (1) the Minister must forthwith furnish the Commission with the reasons for the decision, suspension or revocation to which such appeal relates.

(3) For the purpose of deciding an appeal lodged in terms of subregulation (1), the Commission may require each party to the appeal to furnish such information or evidence as it considers necessary.

(4) The Commission may after due consideration of the appeal, give such decision as it considers appropriate.

CHAPTER 3
REGISTRATION AND LICENSING OF MOTOR VEHICLES
AND INCIDENTAL MATTERS

PART 1
REGISTRATION OF MOTOR VEHICLES

Motor vehicle to be registered

11. Subject to regulations 12 and 13, every motor vehicle in Namibia must, whether or not it is operated on a public road, be registered by the title-holder thereof in accordance with this Part, with the appropriate registering authority.

Motor vehicle deemed to be registered

12. (1) Subject to subregulation (3), a motor vehicle which is registered and licensed in terms of any law of any country other than Namibia and which is not permanently or ordinarily kept in Namibia while it is registered and licensed in terms of that law, is deemed to be registered in terms of this Part while being operated in Namibia by or on behalf of the person in whose name the motor vehicle is registered and licensed.

(2) Subject to subregulation (3), a motor vehicle which is registered in accordance with a law of a contracting State to the Convention and in accordance with the terms of the Convention, is deemed to be registered in terms of this Part while in Namibia -

- (a) during a continuous period of 12 months calculated from the date on which that motor vehicle is brought into Namibia; or
- (b) until the registration ceases to be of force and effect in terms of the Convention,

whichever event is the earlier, and that vehicle may, notwithstanding anything to the contrary contained in this Part, be operated on a public road while it complies with the Convention.

(3) A motor vehicle referred to in subregulation (1) or (2) is no longer deemed to be registered if it does not comply with this regulation while in Namibia.

Motor vehicle exempt from registration

13. (1) The following motor vehicles are not required to be registered in terms of this Part, namely a motor vehicle -

- (a) which is propelled by electrical power derived from overhead wires;

REGULATIONS
Road Traffic and Transport Act 22 of 1999
Road Traffic and Transport Regulations, 2001

- (b) which has crawler tracks;
- (c) which is not -
 - (i) self-propelled;
 - (ii) a caravan;
 - (iii) designed principally for the conveyance of persons or goods, or both; and
 - (iv) operated on a public road;
- (d) which by reason of its dimensions or mass or the mass or a part thereof may not be operated on a public road in terms of section 99 of the Act, and which is not so operated;
- (e) referred to in paragraph (c) and which is drawn by a tractor whether or not it is operated on a public road;
- (f) which is designed exclusively for racing, including a micro midget car or cart and a go-cart, if that motor vehicle is not operated on a public road; or
- (g) which is a self-propelled lawnmower.

(2) For the purposes of subregulation (1), the words “operated on a public road” may not be construed to include the presence of the motor vehicle on a public road -

- (a) while it is being driven to the premises of the owner in order to take delivery thereof;
- (b) while it is being driven across a public road from the one premises of the owner to another over a distance of not more than one kilometre; or
- (c) while it is proceeding, during the period between sunset and sunrise, to a place where repairs to that motor vehicle are to be effected or from a place where repairs to that motor vehicle have been effected.

[paragraph (c) substituted by GN 205/2004]

(3) If a motor vehicle which is exempt in terms of subregulation (1)(c) is operated on a public road contrary to subregulation (2), the title-holder of that motor vehicle is liable for the registration thereof on the date referred to in regulation 15(1)(a)(vii).

Date on which registration of motor vehicle becomes void

- 14.** The registration of a motor vehicle becomes void -
- (a) on the date of change of title-holder or of owner of the motor vehicle, but if the title-holder or owner of the motor vehicle is a partnership and a change of title-holder or owner of the motor vehicle occurs by reason of one of the partners dying or ceasing to be a partner of that partnership or a new partner being admitted thereto, the registering authority concerned may, upon written application to it by

REGULATIONS
Road Traffic and Transport Act 22 of 1999
Road Traffic and Transport Regulations, 2001

or on behalf of that partnership, determine that no change of title-holder or owner is deemed to have occurred in respect of that motor vehicle and that determination is final;

- (b) on the date on which a deregistration certificate in respect of the motor vehicle is issued in terms of regulation 24(3)(c), 89(5)(b) or 90(3)(c);
- (c) if the motor vehicle is subject to an instalment sale transaction or leasing transaction as defined in the Credit Agreements Act, 1980 (Act No. 75 of 1980), on expiry of 31 days from the date of repossession of that motor vehicle by the title-holder, but the registration of a motor vehicle in respect of which the owner fulfils his or her obligation in terms of section 12 of that Act, does not become void;
- (d) if the motor vehicle is acquired from the estate of a deceased person, on the date on which that motor vehicle is acquired or the estate is wound up whichever date is the earlier; or
- (e) on the date determined by the Minister in any circumstances not contemplated in this regulation.

Date and conditions on which motor vehicle is to be registered

15. (1) Subject to subregulation (2), liability for the registration of a motor vehicle arises -

- (a) in the case of a motor vehicle to be registered for the first time in Namibia -
 - (i) if the motor vehicle was manufactured on or after a date determined by the Minister by notice in the *Gazette*, on the date of completion of manufacture of that motor vehicle;
 - (ii) if the motor vehicle was built by a builder on or after a date determined by the Minister by notice in the *Gazette*, on the date of completion of the building of that motor vehicle;
 - (iii) if the motor vehicle was built up from parts by a person other than a builder, on the date of completion of the building of that motor vehicle;
 - (iv) if the motor vehicle was imported by an importer on or after a date determined by the Minister by notice in the *Gazette*, on the date of arrival of that vehicle in Namibia or on the date on which that motor vehicle is cleared in terms of customs and excise legislation, if applicable;
 - (v) subject to regulation 12, if the motor vehicle was acquired outside Namibia, on the date that such motor vehicle is brought into Namibia or on the date on which that motor vehicle is cleared in terms of customs and excise legislation, if applicable;
 - (vi) if it is a motor vehicle which is deemed to be registered in terms of regulation 12, on the date it ceases to be so deemed; or

REGULATIONS
Road Traffic and Transport Act 22 of 1999
Road Traffic and Transport Regulations, 2001

- (vii) if it is a motor vehicle which is exempted from registration in terms of regulation 13 and that exemption is withdrawn or is no longer applicable, on the date of the withdrawal or when that exemption no longer applies;
- (b) in the case of a motor vehicle which was previously registered in Namibia -
 - (i) on the date the registration of that vehicle becomes void, in terms of regulation 14(a), (c) or (d), or if applicable, 14(c); or
 - (ii) which was stolen and deregistered in terms of regulation 89(5) and is recovered, on the date of release of that motor vehicle by the Namibian Police Force; or
- (c) in circumstances not contemplated in the preceding paragraphs, on the date determined by the Minister.

(2) Notwithstanding anything to the contrary contained in this Part, a motor vehicle referred to in subregulation (1)(b) may be operated on a public road for a period of 21 days after the date of liability referred to in this regulation in order to register the motor vehicle while the licence number allocated thereto and the licence disc issued in respect thereof are displayed in the manner contemplated in regulations 48 and 50 respectively.

(3) If it is an issue in any civil or criminal proceedings whether an alleged date is the date referred to in subregulation (1), the date so alleged is, until the contrary is proved, deemed to be the date referred to in that subregulation.

Manner of application for registration of motor vehicle

16. (1) An application for the registration of a motor vehicle, other than a motor vehicle referred to in regulation 23, must be made within 21 days after the date of liability referred to in regulation 15, to the appropriate registering authority on the approved form.

- (2) An application referred to in subregulation (1) must be accompanied by -
 - (a) the acceptable identification of the title-holder of the motor vehicle and, in the case of a body of persons, that of its proxy and representative and a letter of proxy;
 - (b) the acceptable identification of the owner of the motor vehicle and, in the case of a body of persons, that of its proxy and representative and a letter of proxy;
 - (c) the appropriate registration fees prescribed under section 18 of the Road Fund Administration Act, 1999 (Act No. 18 of 1999) and, if applicable, any penalties and arrear fees referred to in regulations 92 and 94;
 - (d) if the motor vehicle is registered in Namibia, the registration certificate or if the motor vehicle is registered in a foreign country, the registration document from that foreign country;
 - (e) if the motor vehicle is acquired from a Government ministry, proof of the acquisition signed by the accounting officer of that ministry;
 - (f) in the case of a motor vehicle which is being registered for the first time -

REGULATIONS
Road Traffic and Transport Act 22 of 1999
Road Traffic and Transport Regulations, 2001

- (i) if required, the particulars of the motor vehicle on the approved form;
- (ii) if it is a new motor vehicle, a certificate from the manufacturer, builder or importer of the motor vehicle containing -
 - (aa) the chassis number expressed in not more than 17 alpha-numerical characters;
 - (bb) if self-propelled, the engine number expressed in not more than 20 alpha-numerical characters;
 - (cc) the make expressed in not more than 30 alpha-numerical characters;
 - (dd) the model name expressed in not more than 20 alpha-numerical characters, and the model- derivative expressed in not more than 20 alpha- numerical characters, neither of which, for the purpose of this subregulation must include the year of manufacture;
 - (ee) other than in the case of a motorcycle, the tare in kilograms expressed in not more than five figures;
 - (ff) if self-propelled, the engine capacity in cubic centimetres expressed in not more than five figures;
 - (gg) in the case of a mini-bus, bus or goods vehicle, the gross vehicle mass in kilograms expressed in not more than six figures;
 - (hh) if self-propelled, the nett engine power to the nearest kilowatt expressed in not more than three figures; and
 - (ii) the model number referred to in regulation 82(1)(e) or a letter of authority contemplated in regulation 81; and
- (iii) the main colour of the motor vehicle concerned;
- (g) if the tare has changed due to any reason, a mass measuring certificate referred to in regulation 101;
- (h) a Police clearance with regard to the motor vehicle except if it is a new motor vehicle; and
- (i) if required by the registering authority -
 - (i) proof of the right to be registered as title-holder of the motor vehicle concerned;
 - (ii) proof of compliance with the provisions of the customs and excise legislation;
 - (iii) where doubt exists regarding the tare of the motor vehicle concerned, a mass measuring certificate referred to in regulation 101; or
 - (iv) any other documentation required by the Minister.

REGULATIONS
Road Traffic and Transport Act 22 of 1999
Road Traffic and Transport Regulations, 2001

(3) If liability for the registration of a motor vehicle arises due to the sale of the motor vehicle by a motor dealer to a banking institution, so that the banking institution may sell or lease that motor vehicle to its client and if the appropriate registering authority of the title-holder of that motor vehicle is the same registering authority as that of the motor dealer, the motor dealer concerned must submit the application referred to in subregulation (1) to the appropriate registering authority.

(4) If the title-holder of the motor vehicle concerned does not permanently reside or carry on business in Namibia, the owner of that motor vehicle must submit the application referred to in subregulation (1) to the appropriate registering authority.

(5) A tricycle and a quadrucycle is exempt from the requirements of subregulation (2)(d), until such date as the Minister may determine by notice in the Gazette.

[Subregulation (5) is inserted by GN 205/2004. The verb "is" should be "are" to be grammatically correct. The word "Gazette" is not italicised.]

(6) A roadworthy certificate must accompany the application for registration of a motor quadrucycle or tricycle.

[subregulation (6) inserted by GN 156/2015 and substituted by GN 98/2016]

Application for duplicate document

16A. An application for a duplicate registration or deregistration certificate must be accompanied by -

- (a) a completed and signed declaration form stating the loss or destruction of the document;
- (b) positive identification of the owner;
- (c) in the case of a representative, his or her identity document and a letter of authorisation to act on behalf of the owner; and
- (d) the fee in terms of section 18 of the Road Fund Administration Act, 1999 (Act No. 18 of 1999).

[regulation 16A inserted by GN 156/2015]

Additional requirements for registration of motor vehicle built up from parts

17. An application for the registration of a motor vehicle referred to in regulation 15(1)(a)(iii) must, in addition to the requirements and documents referred to in regulation 16, be accompanied by -

- (a) an affidavit on the approved form, stating the parts used, the person from whom those parts were acquired and, attached to the form, the receipts of the purchase or donation of such parts;
- (b) if the motor vehicle concerned is built up from a motor vehicle which had become permanently unfit for use as such and was deregistered in terms of regulation 90(3), the deregistration certificate in respect of that motor vehicle; and

REGULATIONS
Road Traffic and Transport Act 22 of 1999
Road Traffic and Transport Regulations, 2001

- (c) a Police clearance in respect of the motor vehicle.

Additional requirements for registration of deregistered motor vehicle

18. An application for the registration of a motor vehicle which was stolen and recovered must, in addition to the requirements and documents referred to in regulation 16, be accompanied by the Police clearance issued in respect of the motor vehicle.

Additional requirements for registration of a motor vehicle deregistered pursuant to regulation 32A

18A. An application for registration of a motor vehicle referred to in regulation 32A must, in addition to the requirements contemplated in regulation 16, be accompanied by -

- (a) the registration certificate in respect of that motor vehicle or a duplicate registration certificate contemplated in regulation 16A, in case where the owner has lost the registration certificate; and
- (b) a mass measuring certificate obtained in the manner set out in regulation 101.

[Regulation 18A is inserted by GN 31/2019. The phrase "in case" in paragraph (a) should be "in a case" or "in the case".]

Additional requirements for registration of motor vehicle acquired from deceased estate

19. An application for the registration of a motor vehicle that is acquired from the estate or a deceased person must, in addition to the requirements and documents referred to in regulation 16, be accompanied by a document substantiating the acquisition of the motor vehicle.

Additional requirements for registration of motor vehicle acquired due to repossession by title-holder

20. An application for the registration of a motor vehicle referred to in regulation 14(c) must, in addition to the requirements and documents referred to in regulation 16, be accompanied by a certified copy of -

- (a) the court order; or
- (b) the voluntary surrender documentation, but an affidavit made by the title-holder of that motor vehicle explaining the circumstances under which the vehicle was repossessed may be submitted in the case where the voluntary surrender documentation cannot be obtained, as proof of the right of the title-holder to repossess that motor vehicle.

Additional requirements for registration of motor vehicle that is registered outside borders of Namibia

21. (1) An application for the registration of a motor vehicle referred to in regulation 15(1)(a)(v) or (vi) must, in addition to the requirements and documents referred to in regulation 16, be accompanied by -

- (a) proof of compliance with the provisions of customs and excise legislation;

REGULATIONS
Road Traffic and Transport Act 22 of 1999
Road Traffic and Transport Regulations, 2001

- (b) if the motor vehicle is registered outside the border of Namibia, the documents relating to the registration and licensing or the motor vehicle concerned issued in the country where that motor vehicle is registered; and
 - (c) a Police clearance in respect of the motor vehicle issued in the country or origin and which, in the case of a SARPCCO country, must be in the form of a SARPCCO clearance certificate or if a Police clearance is not available, an Interpol police clearance.
- (2) For the purposes of paragraph (c) of subregulation (1) -
- (a) “SARPCCO country” means any of the countries which, together with Namibia, are represented at the Southern African Regional Police Chief’s Cooperation Organisation, being Angola, Botswana, Lesotho, Malawi, Mozambique, South Africa, Swaziland, Tanzania, Zambia and Zimbabwe: and
 - (b) “SARPCCO clearance certificate” means the “SARPCCO EXPORT/IMPORT EXPORTACAO/IMPORTACAO - MOTOR VEHICLE CLEARANCE” as accepted by the said Southern African Regional Police Chiefs Cooperation Organization.

Manner of registration of motor vehicle

22. (1) On receipt of the application referred to in regulation 16, the registering authority may, and if the applicant so requires, must issue an assessment showing the penalties and fees referred to in regulations 92 and 94, for the registration of the motor vehicle concerned.

(2) The registering authority must, subject to regulation 94(2), on payment of the amount shown in the assessment, and if satisfied that the application is in order -

- (a) register the motor vehicle concerned;
- (b) record in the register of motor vehicles referred to in regulation 366(6)(a) the particulars of the motor vehicle concerned, title- holder and owner of that motor vehicle; and
- (c) issue a registration certificate on the approved form.

(3) The title-holder must upon registration of the motor vehicle concerned, forthwith notify the owner of the registration.

(4) Notwithstanding anything to the contrary contained in these regulations, a registering authority may not register a motor vehicle of which the steering mechanism is positioned on the left hand side of that vehicle.

[subregulation (4) inserted by GN 205/2004]

Manner of registration by manufacturer, builder or importer who is registering authority

23. (1) From a date determined by the Minister by notice in the *Gazette*, a manufacturer, builder or importer who is a registering authority, must within seven days from the date of liability referred to in regulation 15(1) -

REGULATIONS
Road Traffic and Transport Act 22 of 1999
Road Traffic and Transport Regulations, 2001

- (a) register the motor vehicle manufactured, built or imported by it; and
- (b) record the particulars in relation to the -
 - (i) motor vehicle concerned; and
 - (ii) title-holder and owner of such motor vehicle, in the register of motor vehicles referred to in regulation 366(6)(a).

(2) The manufacturer, builder or importer referred to in subregulation (1), must record in the register of motor vehicles referred to in regulation 366(6)(a) any change of title-holder or owner in respect of every motor vehicle manufactured, built or imported by him or her until a registration certificate has been issued in respect of such motor vehicle.

(3) The manufacturer, builder or importer referred to in subregulation (1) is not liable for payment of the registration fees referred to in regulation 16(2)(c).

Deregistration of registered motor vehicle which becomes exempt from registration

24. (1) If a registered motor vehicle becomes exempt from registration in terms of regulation 13, the title-holder of the motor vehicle must apply for the deregistration of that motor vehicle on the approved form, to the appropriate registering authority.

- (2) The application referred to in subregulation (1) must be accompanied by -
 - (a) the acceptable identification of the title-holder and, if the title-holder is a body of persons, that of its proxy and representative and a letter of proxy;
 - (b) the registration certificate of the motor vehicle concerned; and
 - (c) the fee prescribed in terms of section 18 of the Road Fund Administration Act, 1999.

(3) On receipt of the application referred to in subregulation (1), the registering authority must -

- (a) satisfy itself that the application is in order;
- (b) update the particulars pertaining to the motor vehicle concerned in the register of motor vehicles referred to in regulation 366(6)(a); and
- (c) issue a deregistration certificate on the approved form to the title-holder of the motor vehicle concerned.

PART 2
LICENSING OF MOTOR VEHICLES

Motor vehicle to be licensed

25. Subject to regulations 26 and 27, every motor vehicle in Namibia must, whether or not it is operated on a public road, be licensed by its owner in accordance with this Part, with the appropriate registering authority.

REGULATIONS
Road Traffic and Transport Act 22 of 1999
Road Traffic and Transport Regulations, 2001

Motor vehicle deemed to be licensed

26. (1) Despite anything to the contrary contained in this Part, a motor vehicle which is deemed to be registered in terms of regulation 12 is deemed to be licensed in terms of this Part.

(2) A motor vehicle owned by a motor dealer for the purposes of sale or exchange in the course of his or her business as a motor dealer, and if the motor vehicle is not operated on a public road, except under a motor trade number, is deemed, despite anything to the contrary contained in this Part, to be licensed in terms of this Part.

(3) A motor vehicle referred to in subregulation (1) is no longer deemed to be licensed with effect from the date referred to in regulation 12(3), and the owner of the motor vehicle is liable to licence that motor vehicle in terms of this Part.

Motor vehicle exempt from licensing

27. A motor vehicle that is exempt from registration in terms of regulation 13 is not required to be licensed in terms of this Part.

Motor vehicles exempt from motor vehicle licence fees

28. (1) A motor vehicle -

- (a) which is a trailer, other than a semi-trailer;
- (b) which is self-propelled and is a tractor, water boring machine, threshing machine, harvester, harrow, mower, baler, scraper, leveller, spraying machine, crane, plough or a similar vehicle, the owner of which is a *bona fide* farmer, and which is used only in connection with that farmer's own farming activities;
- (c) which is not designed principally for the conveyance of goods or persons or both on a public road and which permanently incorporates machinery for the purposes of -
 - (i) road-making;
 - (ii) road-sweeping;
 - (iii) earthmoving;
 - (iv) excavation;
 - (v) pipe-laying;
 - (vi) construction;
 - (vii) water-boring;
 - (viii) loading;
 - (ix) lifting;

REGULATIONS
Road Traffic and Transport Act 22 of 1999
Road Traffic and Transport Regulations, 2001

- (x) internal handling;
- (xi) drilling; or
- (xii) any like purpose determined by the Minister;
- (d) which is a trailer for pre-mix purposes;
- (e) which is a mobile hammer;
- (f) which is commonly known as a stock-car, racing car or a racing motorcycle, which is used solely for racing purposes and which is certified as such by the secretary of the racing club of which the owner of the motor vehicle is a member and that motor vehicle is not operated on a public road;
- (g) which is in the opinion of the Minister over 40 years of age, and which is used only for -
 - (i) any race or sport referred to in regulation 352;
 - (ii) an event organised by a properly constituted motor club;
 - (iii) exhibition purposes; or
 - (iv) travelling to and from a filling station for the purpose of filling the motor vehicle with fuel;
- (h) which is designed or adapted solely or principally for fighting fires and which is registered as a fire-fighting vehicle; or
- (i) which may only be operated on a public road under an authorisation in terms of section 99 of the Act;
- (j) of which the owner is a person who is entitled to diplomatic immunity under section 4 of the Diplomatic Privileges Act, 1951 (Act No. 71 of 1951),

is exempt from the payment of motor vehicle licence fees.

(2) For the purposes of this regulation, the words “operated on a public road” must not be construed to include the presence of a motor vehicle on a public road for the purpose of -

- (a) being driven to the premises of the owner in order to take delivery thereof;
- (b) crossing or driving along a public road from the premises of the owner to another over a distance of not more than one kilometre; or
- (c) proceeding to or from a place where repairs are to be or have been effected to the motor vehicle.

(3) If a motor vehicle referred to in subregulation (1) is operated on a public road contrary to subregulation (2), the motor vehicle is no longer exempt in terms of this regulation and the owner of that motor vehicle is liable for the licensing thereof with effect from the date it is so operated.

REGULATIONS
Road Traffic and Transport Act 22 of 1999
Road Traffic and Transport Regulations, 2001

Date on which motor vehicle licence and licence disc of motor vehicle becomes void

29. The motor vehicle licence and licence disc of a motor vehicle becomes void on the date -

- (a) referred to in regulation 14(a), (c), (d) or (e), 32(4) or 44(1);
- (b) on which a new licence number is allocated as referred to in regulation 35;
- (c) on which a specific licence number is issued in terms of regulation 36;
- (d) on which a licence number is transferred in terms of regulation 36A;
- (e) on which a personalised licence number is issued or transferred in terms of this Chapter;
- (f) of surrender of a personalised licence number as contemplated in regulation 39F;
- (g) on which a personalised licence number becomes void in terms of regulation 41(1)(b) and (c);
- (h) of cancellation of a personalised licence number, where a decision in terms of regulation 42(5) includes an order for the cancellation of a personalised licence number;
- (i) of issue of an acknowledgement of receipt in terms of regulation 89(5)(c) or 90(3)(b) in respect of the motor vehicle concerned;
- (j) of deregistration of the motor vehicle in terms of this Chapter;
- (k) on which the motor vehicle is acquired or the estate is wound up, whichever is the earlier, if the motor vehicle concerned is acquired from the estate of a deceased person;
- (l) if the motor vehicle is subject to an installment sale transaction or leasing transaction, 31 days from the date of repossession of the motor vehicle by the title-holder, but the motor vehicle licence and licence disc of a motor vehicle of which the owner fulfils his or her obligation in terms of section 12 of the Credit Agreements Act, 1980 (Act No. 75 of 1980) does not become void;
- (m) on which the motor vehicle licence is destroyed in terms of regulation 164(1)(a); or
- (n) determined by the Minister in circumstances not contemplated in this regulation.

[regulation 29 amended by GN 45/2004 and substituted by GN 104/2007]

Date on which motor vehicle is to be licensed

30. (1) Subject to subregulation (3), liability for the licensing of a motor vehicle arises on the date -

REGULATIONS
Road Traffic and Transport Act 22 of 1999
Road Traffic and Transport Regulations, 2001

- (a) on which liability for the registration of that motor vehicle arises in terms of regulation 15;
- (b) on which a new licence number is allocated as referred to in regulation 35;
- (c) on which the motor vehicle licence and licence disc of a motor vehicle become void as specified in regulation 29(e), (f), (g), (h) and (n);
- (d) of the expiry of the licence of such motor vehicle in terms of regulation 33;
- (e) referred to in regulation 44(1);
- (f) of release by the Namibian Police Force of a stolen motor vehicle which was recovered but has not been deregistered in terms of regulation 89(5);
- (g) on which the licence disc, that includes the roadworthy certificate and operator card, is lost, stolen or destroyed; or
- (h) determined by the Minister in circumstances not contemplated in this regulation.

[subregulation (1) substituted by GN 104/2007]

(2) The date of liability referred to in subregulation (1)(d) must be construed to arise on the first day of the month following the date of expiry of the existing licence.

(3) Notwithstanding anything to the contrary contained in these regulations, a motor vehicle of which the licence disc issued in respect of that motor vehicle or the licence number allocated to that motor vehicle has expired may, from the date of expiry, continue to operate on a public road for a grace period of 21 days as contemplated in regulation 95 and on condition that the expired licence number and the licence disc are displayed in accordance with regulations 48 and 50 respectively.

[subregulation (3) substituted by GN 205/2004]

(4) If it is in issue in any civil or criminal proceedings whether an alleged date is the date referred to in subregulation (1), the date so alleged is, until the contrary is proved, deemed to be the date referred to in that subregulation.

Manner of application for licensing of motor vehicle

31. (1) An application for the licensing of a motor vehicle must be made to any registering authority on an approved form by the owner of the motor vehicle, within 21 days after the date of liability referred to in regulation 30, but the owner may licence his or her motor vehicle on any date prior to the date of liability referred to in that regulation for a further period of 12 months and subregulation (3) is applicable to that transaction.

[subregulation (1) substituted by GN 31/2019]

- (2) An application referred to in subregulation (1) must be accompanied by -
 - (a) acceptable identification of the owner of the motor vehicle and, if the owner is a body of persons, acceptable identification of its proxy and representative and a letter of proxy;

REGULATIONS
Road Traffic and Transport Act 22 of 1999
Road Traffic and Transport Regulations, 2001

- (b) the appropriate motor vehicle licence fees prescribed in terms of section 18 of the Road Fund Administration Act, 1999 (Act No. 18 of 1999);
- (c) if applicable the penalties and arrear licence fees referred to in regulations 92 and 94;
- (d) if required in terms of section 58 of the Act, a roadworthy certificate;
- (e) if the Government owns the motor vehicle concerned, a licence number referred to in regulation 34(3) allocated by the relevant Ministry;
- (f) if applicable, the motor vehicle licence;
- (g) a certified copy of the certificate of entitlement issued in terms of regulation 39(11), if the applicant has applied for a personalized licence number; or
- (h) in the case of a motor vehicle that is subject to the payment of travelling distance charges as contemplated in section 18(1)(a) of the Road Fund Administration Act, 1999 (Act No. 18 of 1999), proof of payment of such charges.

[subregulation (2) amended by GN 45/2005, and substituted by GN 104/2007 and by GN 73/2008]

(3) If an application is made in terms of subregulation (1) and the owner of the motor vehicle submits a motor vehicle licence of which the period of validity has not yet expired, the fees payable for the licence applied for, must be reduced by one twelfth per month or part thereof for every month the licence is still valid, but the motor vehicle licence fees payable for the licence of a motor vehicle referred to in regulations 24, 89(1)(c) and 90(1)(b), may not be so reduced.

Manner of licensing of motor vehicle

32. (1) On receipt of the application referred to in regulation 31, the registering authority may, and if the applicant so requires, must issue an assessment showing the fees and penalties referred to in regulation 31(2)(b) and (c), for the licensing of the motor vehicle concerned.

(2) The registering authority must, subject to regulation 94(2), on payment of the amount shown in the assessment and if satisfied that the application is in order -

- (a) licence the motor vehicle concerned;
- (b) allocate a licence number to the motor vehicle concerned, if a licence number has not been allocated to that motor vehicle previously, and where the licence mark of the registering authority concerned begins with the letter "0", that licence number may not end on the number "0";
- (c) update the particulars pertaining to that motor vehicle in the register of motor vehicles referred to in regulation 366(6)(a);
- (d) issue a motor vehicle licence on the approved form to the owner of that motor vehicle;

REGULATIONS
Road Traffic and Transport Act 22 of 1999
Road Traffic and Transport Regulations, 2001

- (e) subject to subregulations (4) and (6), issue a licence disc on the approved form, which serves as proof that the motor vehicle is licenced; and

[paragraph (e) substituted by GN 73/2008]

- (f) issue a confirmation on the approved form, if applicable.

(3) The licence disc referred to in subregulation (2)(e) must be completed in black non-fading ink.

(4) If a roadworthy certificate is required and the application referred to in regulation 31 is not accompanied by that certificate, the registering authority may not issue a licence disc until the owner of the motor vehicle submits the roadworthy certificate, but if the roadworthy certificate is submitted after the month in which the motor vehicle is licenced, the motor vehicle licence of that motor vehicle becomes void on the day the roadworthy certificate is submitted and on that date the owner becomes liable for the licencing of that motor vehicle.

(5) When the owner of the motor vehicle referred to in subregulation (4) obtains a roadworthy certificate, he or she must -

- (a) submit the certificate to the appropriate registering authority; and
- (b) apply on the approved form for a licence disc in respect of the motor vehicle concerned.

(6) If the operator of the motor vehicle concerned is liable to pay travelling distance charges in relation to the motor vehicle concerned, and the application for licencing of the motor vehicle referred to in regulation 31(2)(h) is not accompanied by proof of payment of such charges, the registering authority may not issue a licence disc until the owner of that motor vehicle submits such proof to that registering authority.

[subregulation (6) inserted by GN 73/2008]

Automatic deregistration of a motor vehicle not licenced within the prescribed period

32A. (1) If the motor vehicle is required to be licenced in terms of the Regulations, and an application for renewal of such licence was not received by the registering authority within a period of three years from the date of liability to licence the motor vehicle, the motor vehicle concerned must be deregistered automatically.

(2) When the motor vehicle is deregistered in terms of subregulation (1), the owner is, on the date referred to in regulation 15(1)(b), liable for re-registration in terms of regulation 18A, and such owner is liable to licence such vehicle as referred to in regulation 31.

(3) The motor vehicle owner is liable for all penalties and arrear licence fees contemplated in regulation 92 and 94 up to the date of automatic re-registration referred to in subregulation (1).

[Regulation 32A is inserted by GN 31/2019. The word "regulation" should be "regulations" (plural).]

Period of validity of motor vehicle licence and licence disc

REGULATIONS
Road Traffic and Transport Act 22 of 1999
Road Traffic and Transport Regulations, 2001

33. A motor vehicle licence and licence disc are valid for a period of 12 months from the first day of the month in which the licence and licence disc were issued, and the date or expiry of that licence must be shown on the motor vehicle licence and licence disc, but if the owner applies for the renewal of the current motor vehicle licence and licence disc in terms of regulation 43(2) before the expiry date of that motor vehicle licence and licence disc, the period of validity of the new motor vehicle licence and licence disc must be calculated from the first day of the month which follows on the expiry date of the current motor vehicle licence and licence disc.

[The word *disk* appears once in regulation 33 spelt with a “k”; most other uses of the word in these regulations use the spelling “disc”.]

Licence number of motor vehicle

34. (1) Subject to subregulations (3) and (4) and regulation 37, every motor vehicle licensed in Namibia must be allocated a licence number by the registering authority, consisting of a combination of the letter “N”, denoting Namibia, a maximum of six numbers, followed by a licence mark comprising of a maximum of two letters denoting the registering authority at which the motor vehicle is licensed.

(2) The Minister shall by notice in the Gazette, determine the letters denoting each registering authority in Namibia.

(3) The licence number of a motor vehicle of which a Government ministry is the owner, may consist of a combination of letters and numbers determined by the Minister by notice in the *Gazette*.

(4) In lieu of registration and licensing by a registering authority the Ministry responsible for Foreign Affairs of Namibia must register and assign, free of charge, a licence mark and number to every motor vehicle owned by a person registered as being entitled to diplomatic immunity under section 4 of the Diplomatic Privileges Act, 1951 (Act No. 71 of 1951), and the same licence mark and number may not be assigned to more than one motor vehicle.

Minister may change allocated licence number

35. The Minister, or in relation to a motor vehicle referred to in regulation 34(4), the Minister responsible for Foreign Affairs of Namibia, may, on the conditions he or she determines, change the licence number allocated to a motor vehicle.

Specific licence numbers

36. (1) For the purpose of this Part, a “specific licence number” means -

- (a) a licence number reserved by the Minister in terms of subregulation (2); or
- (b) a licence number requested for in terms of subregulation (3)(b).

[The word “for” after “requested” is superfluous.]

(2) The Minister may, as he or she may consider necessary reserve, as specific licence numbers, the licence numbers referred to in regulation 34(1) and (2), for the purpose of allocation to any person who requests for such number in terms of subregulation (3).

REGULATIONS
Road Traffic and Transport Act 22 of 1999
Road Traffic and Transport Regulations, 2001

[The word “for” after “requests” is superfluous.]

(3) A person may, on an approved form and on the payment of the fee prescribed in Schedule 1, request the appropriate registering authority to allocate -

- (a) a specific licence number reserved in terms of subregulation (2); or
- (b) any other specific licence number of such person’s choice,

to a motor vehicle of which such person is the owner.

(4) On receipt of a request made in terms of subregulation (3), the registering authority must, if satisfied that the specific licence number requested for in terms of that subregulation has not been allocated to another motor vehicle, allocate such licence number to the motor vehicle which is owned by the person referred to in that subregulation.

[regulation 36 substituted by GN 45/2005]

Transfer of a licence number

36A. (1) An owner of a motor vehicle may apply to an appropriate registering authority for the transfer of a licence number allocated to a motor vehicle -

- (a) from a motor vehicle of which the applicant is an owner to another motor vehicle of which the applicant is the owner; or
- (b) from the motor vehicle of one owner to a motor vehicle owned by another person.

(2) The application referred to in subregulation (1) must be accompanied by the fee prescribed in Schedule 1.

(3) On receipt of an application made in terms of subregulation (1), the registering authority may transfer the relevant number to the respective motor vehicle referred to in the application.

[regulation 36A inserted by GN 45/2005]

Personalised licence numbers

37. (1) A person may apply in accordance with regulation 38 for the allocation of a licence number of his or her choice, referred to as a personalised licence number, to motor vehicle of which he or she is the owner or is becoming the owner.

[Subregulation (1) is substituted by GN 104/2007. The word “a” appears to have been omitted before the term “motor vehicle”.]

(2) The issuing authority or person may authorise any number plate manufacturer to manufacture personalised number plates on the conditions determined by the issuing authority or person and only such an authorised manufacturer may manufacture personalised number plates.

(3) A personalised licence number may consist of a maximum of seven alphabetical or numerical characters or a combination of alphanumerical characters.

REGULATIONS
Road Traffic and Transport Act 22 of 1999
Road Traffic and Transport Regulations, 2001

- (4) The characters referred to in subregulation (3), must be followed by -
- (a) an emblem of the National Flag of Namibia, which emblem must comply with the description set out in Schedule 6 to the Namibian Constitution; and
 - (b) the letters “NA”, depicting “Namibia”.

[subregulation (4) substituted by GN 104/2007]

(5) A personalised number plate must comply with the Standard Specification of the South African Bureau of Standards SABS 1116 “Retro-Reflective Registration Plates for Motor Vehicles”, Part 4:1996” Registration Plates (plastics)’ as published under South African Government Notice No. R 1644 of 3 August of 1984 and the characters must be blue on a white background as contemplated in that specification.

(6) Despite the specification referred to in subregulation (5) the National Flag of Namibia must be in full colour.

[subregulation (6) substituted by GN 104/2007]

- (7) A personalised licence number must be displayed -
- (a) with all the characters and the National Flag of Namibia in one line; or
 - (b) if the size of the motor vehicle prevents the display referred to in paragraph (a), with some characters in one line and the remainder of the characters in a line immediately below.

[subregulation (7) amended by GN 104/2007]

(8) A personalised licence number may not be of an obscene, indecent or immoral nature or such that it would offend the public morals or decency.

(9) A person may not issue, manufacture or affix to a motor vehicle a personalised number plate, unless in accordance with these regulations.

Application for personalised licence number

38. An application for a personalised licence number must be made to the appropriate registering authority and must be accompanied by -

- (a) acceptable identification document of the applicant;
- (b) up to three personalised licence numbers, in the order of the applicant’s preference; and
- (c) a declaration, made under oath before a commissioner of oaths, declaring that the applicant is to his or her knowledge not aware of any copyright vesting in the expression that is applied for to be used as a personalised licence number or if copyright so vests in that expression a declaration to the effect that the applicant has been given the right of use of that expression.

[regulation 38 substituted by GN 104/2007]

REGULATIONS
Road Traffic and Transport Act 22 of 1999
Road Traffic and Transport Regulations, 2001

Issue of personalised licence number

39. (1) For the purpose of these regulations the Minister must designate an issuing authority.

(2) On receipt of an application for a personalised licence number in terms of regulation 38, the appropriate registering authority must, upon finding the application to be complete and accompanied by the documentation referred to in regulation 38, forward the application to the issuing authority.

(3) On receipt of an application in terms of subregulation (2), the issuing authority must -

- (a) satisfy itself that the application is complete and accompanied by the documentation referred to in regulation 38;
- (b) determine whether the requested characters are obscene, indecent or of an immoral nature or would not offend public morals or decency; and
- (c) determine -
 - (i) whether the personalised licence number applied for is not similar to a homophone of, or a replica of a personalised licence number that has already been allocated by the issuing authority in relation to a motor vehicle; or
 - (ii) whether an application for a similar personalised licence number has been refused on grounds that it is of an obscene, indecent or of an immoral nature or would offend the public morals or standards of decency.

[The phrase “of an” before the word “immoral” are superfluous.]

(4) If the issuing authority is satisfied that the application for a personalised licence number complies with subregulation (3), the issuing authority must -

- (a) issue a confirmation of allocation on the approved form, indicating that the personalised licence number has been approved by the issuing authority;
- (b) update the register of personalised licence numbers referred to in regulation 366(8) accordingly; and

[The word “personalised” is misspelt in the *Government Gazette*, as reproduced above.]

- (c) notify the appropriate registering authority accordingly, and forward the confirmation of allocation to the appropriate registering authority.

(5) In the case of two or more persons applying for the same expression to be used as a personalised licence number, the issuing authority must allocate the expression to the first application received by the issuing authority.

(6) If the issuing authority is satisfied that the application for a personalised licence number does not comply with subregulation (3), the issuing authority must refuse the application and notify the appropriate registering authority accordingly.

REGULATIONS
Road Traffic and Transport Act 22 of 1999
Road Traffic and Transport Regulations, 2001

(7) If an application for a personalised licence number is refused in terms of subregulation (6), the appropriate registering authority must notify the applicant accordingly and provide the applicant with reasons for the refusal.

(8) If an application for a personalised licence number is approved in terms of subregulation (4), the appropriate registering authority must notify the applicant accordingly, and provide the applicant with the confirmation of allocation.

(9) On receipt of the confirmation of allocation in terms of subregulation (8), the applicant must within 21 days from the date of receipt submit the confirmation of allocation together with the appropriate fee prescribed in Schedule 1, to the appropriate registering authority.

(10) If the applicant fails to pay the appropriate fee referred to in subregulation (9) within the 21 days referred to in that subregulation, the confirmation of allocation of the personalised licence number expires.

(11) On receipt of the confirmation of allocation and the appropriate fee, the appropriate registering authority must -

- (a) issue a certificate of entitlement on an approved form to the applicant;
- (b) notify the issuing authority on the approved form that a certificate of entitlement has been issued;
- (c) if the certificate of entitlement is issued to a person who is the owner of a motor vehicle that is registered and licensed in terms of this Chapter and if the personalised licence number applied for is to be displayed on that motor vehicle, licence the motor vehicle in accordance with this Chapter, and the appropriate registering authority may retain the licence until the personalised licence number plates are collected in terms of subregulation (15); and
- (d) update the register of motor vehicles referred to in regulation 366(6)(a) accordingly.

(12) On receipt of the notification referred to in subregulation (11)(b), the issuing authority must issue a works order on the approved form and forward it to the number plate manufacturer referred to in regulation 37(2).

(13) A number plate manufacturer -

- (a) may only manufacture a personalised number plate on receipt of a works order from the issuing authority;
- (b) must manufacture the required set of personalised number plates within the period determined in the authorisation referred to in regulation 37(2); and
- (c) must forward the completed personalised number plates to the appropriate registering authority.

REGULATIONS
Road Traffic and Transport Act 22 of 1999
Road Traffic and Transport Regulations, 2001

(14) On receipt of the personalised number plates in terms of subregulation (13) the appropriate registering authority must notify the holder of the certificate of entitlement that the personalised number plates have been manufactured.

(15) The holder of the certificate of entitlement must as soon as reasonably possible after receipt of the notification referred to in subregulation (14) collect the personalised number plates and display it in accordance with regulations 48(4) to (8).

[The pronoun “it” does not agree with the noun “personalised number plates”.]

(16) If a personalised number plate is lost, stolen, damaged or destroyed the owner of the motor vehicle to which the personalised number plate relates may apply to the issuing authority for authorisation for the remanufacturing of the personalised number plate concerned and such application must be accompanied by the appropriate fee prescribed in Schedule 1.

(17) If the issuing authority is satisfied that the applicant is the owner of the motor vehicle to which the personalised licence number has been allocated, it must in terms of subregulation (16), authorise the manufacture of a substitute personalised number plate in accordance with this regulation.

[regulation 39 substituted by GN 104/2007]

Conditions of the certificate of entitlement

39A. (1) Subject to subregulation (5), the certificate of entitlement issued in terms of regulation 39(11) reflects the holder’s right to a personalised licence number.

(2) The personalised licence number reflected in the certificate of entitlement may only be displayed on personalised licence plate -

[The word “a” appears to have been omitted before the term “personalised licence plate”.]

- (a) which complies with regulation 37(5); and
- (b) affixed to a motor vehicle of which the holder is the owner or title holder.

(3) If the holder of a certificate of entitlement is the owner or title holder of a motor vehicle licensed in the name of the holder of the right reflected in the certificate of entitlement, that holder may, subject to regulation 39(11)(c), continue to operate that motor vehicle on a public road under the licence number allocated to that motor vehicle in terms of regulation 32, until such time as the appropriate registering authority provide the holder of the certificate of entitlement with the personalised number plate.

(4) If the holder of the certificate of entitlement is not the owner or title holder of a motor vehicle the holder must, subject to subregulation (5), if he or she becomes an owner or title holder of a motor vehicle -

- (a) register and licence that motor vehicle, within 21 days from the date of liability referred to in regulations 15 and 30, at the appropriate registering authority in accordance with this Chapter; and
- (b) operate the motor vehicle under a temporary permit in accordance with Part 4 of this Chapter until the appropriate registering authority provides that holder with the

REGULATIONS
Road Traffic and Transport Act 22 of 1999
Road Traffic and Transport Regulations, 2001

personalised number plates and allocates that personalised licence number to that motor vehicle, if it considers it necessary.

(5) The right of the holder to a personalised licence number expires after 90 days from the date of issue of the certificate of entitlement, if that holder fails to licence the motor vehicle as contemplated in this regulation, and that holder is not entitled to a refund of the fees paid by him or her.

(6) The holder of a right to a personalised licence may not transfer that right to another person, except in accordance with this Part.

[regulation 39A inserted by GN 104/2007]

Circumstances under which a personalised licence number may be retained or transferred

39B. A holder of a right to a personalised licence number may -

- (a) if there is a change of owner or title holder of the motor vehicle to which the personalised licence number relates -
 - (i) retain that number in the manner and on the conditions prescribed in regulation 39C; or
 - (ii) transfer the right to that number to the new owner of the motor vehicle in the manner and on the conditions prescribed in regulation 39C;
- (b) if there is no change of owner or title holder of a motor vehicle to which the personalised licence number relates, transfer the right to another owner of a motor vehicle in the manner and on the conditions prescribed in regulation 39D; or
- (c) apply for the reallocation of the personalised licence number from one motor vehicle of which he or she is the owner or title holder to another vehicle of which he or she is the owner or title holder in the manner and on the conditions prescribed in regulation 39E.

[regulation 39B inserted by GN 104/2007]

Retention or transfer of personalised licence number in case of change of owner or title holder of motor vehicle to which personalised licence number was allocated

39C. (1) The holder of a right to a personalised licence number that has been allocated to a motor vehicle of which he or she is an owner or title holder may, if there is a change of owner of the motor vehicle

- (a) retain the personalised licence number for allocation to another motor vehicle of which he or she is the owner or title holder or is becoming the owner or title holder; or
- (b) transfer the right to the personalised licence number to the new owner or title holder of the motor vehicle.

(2) If the holder of a right to a personalised licence number retains the personalised licence number in terms of subregulation (1)(a), and that holder is the owner or title holder of

REGULATIONS
Road Traffic and Transport Act 22 of 1999
Road Traffic and Transport Regulations, 2001

another motor vehicle which the holder intends to operate on a public road under that personalised number, the holder must apply to the appropriate registering authority for the retention of the number, and the application must be accompanied by -

- (a) a certified copy of the certificate of entitlement of that holder; and
- (b) an application for the licensing of the motor vehicle concerned in accordance with this Chapter.

(3) On receipt of an application for the retention of a personalised licence number and an application for the licensing of the motor vehicle concerned in terms of subregulation (2), the appropriate registering authority must, if satisfied that both applications are complete, forward the application for the retention of the personalised licence number to the issuing authority.

(4) On receipt of an application for the retention of a personalised licence number the issuing authority must, if satisfied that the application is complete -

- (a) allocate the personalised licence number to the motor vehicle contemplated in subregulation (2)(a);
- (b) notify the appropriate registering authority that the personalised licence number has been retained by it for allocation to another vehicle of which the holder of the right to the personalised licence number is the owner, and the appropriate registering authority may proceed with the licensing of the motor vehicle concerned in accordance with this Chapter; and
- (c) update the register of personalised licence numbers referred to in regulation 366(8) accordingly.

(5) If, on the date of application for the retention of the personalised licence number, the holder of the right to the personalised licence number is not the owner or title holder of another motor vehicle, the issuing authority may retain that personalised licence number for a period of 90 days from the date of receipt of the application for the retention of the personalised licence number, on condition that -

- (a) the holder must, if he or she becomes an owner or title holder of a motor vehicle, register and licence that motor vehicle within 21 days from the date of liability referred to in regulations 15 and 30, at the appropriate registering authority in accordance with this Chapter; and
- (b) if the holder referred to in paragraph (a), does not exercise his or her right to the personalised licence number in relation to a motor vehicle within 90 days the holder's right to that personalised licence number expires and the holder is not entitled to a refund of the fees paid by him or her.

(6) If the holder of a right to a personalised licence number transfers the right to the personalised licence number together with the motor vehicle to which that personalised licence number has been allocated as contemplated in subregulation (1)(b), the new owner or title holder of that motor vehicle must register and licence that motor vehicle in accordance with this Chapter.

(7) An application for the registration and licensing of a motor vehicle contemplated in subregulation (6) must comply with regulation 38 and must be accompanied by the certificate of

REGULATIONS
Road Traffic and Transport Act 22 of 1999
Road Traffic and Transport Regulations, 2001

entitlement, and regulations 39(4) to (16) and 39A apply with necessary changes to that application.

[regulation 39C inserted by GN 104/2007]

Transfer of right to personalised licence number by holder to another person

39D. (1) The holder of a right to a personalised licence number allocated to a motor vehicle of which he or she is the owner or title holder may transfer that right to another person.

(2) The holder of a right to a personalised licence number who intends to transfer that right must -

- (a) notify the appropriate registering authority of the transfer on the approved form; and
- (b) provide the person to whom the right is to be transferred with the certificate of entitlement.

(3) On receipt of a notification in terms of subregulation (2), the appropriate registering authority must update the register of motor vehicles referred to in regulation 366(6)(a) accordingly.

(4) The person to whom the right to a personalised licence number is transferred, must within 21 days from the date of transfer, apply at the appropriate registering authority for a certificate of entitlement, and regulations 39 and 39A apply with the necessary changes to an application made in terms of this subregulation.

(5) The application referred to in subregulation (4) must, in addition to the requirements referred to in regulation 38, be accompanied by the certificate of entitlement referred to in subregulation 2(b).

[regulation 39D inserted by GN 104/2007]

Transfer of personalised licence number between motor vehicles of which holder of right to personalised licence number is owner or title holder

39E. (1) The holder of a right to a personalised licence number which has been allocated to a motor vehicle of which he or she is the owner or title holder may have that number transferred and allocated to another motor vehicle of which he or she is the owner or title holder.

(2) The holder of a right to a personalised licence who intends to transfer the personalised licence number as stated in subregulation (1) must make an application for the transfer on the approved form at the appropriate registering authority.

(3) An application referred to in subregulation (2) must, in addition to the requirements prescribed in regulation 38, be accompanied by -

- (a) the appropriate fee prescribed in Schedule 1;
- (b) a certified copy of the certificate of entitlement of the holder; and

REGULATIONS
Road Traffic and Transport Act 22 of 1999
Road Traffic and Transport Regulations, 2001

(c) an application for the licensing of both motor vehicles in accordance with regulation 31.

(4) On receipt of both applications contemplated in terms of subregulation (3)(c), the appropriate registering authority must, if satisfied that the applications are complete -

- (a) allocate the personalised licence number to the motor vehicle concerned in accordance with regulations 39(4) to 39(11) and 39A;
- (b) licence both motor vehicles in the manner contemplated in regulation 32; and
- (c) update the register of motor vehicles referred to in regulation 366(6)(a) accordingly.

[regulation 39E inserted by GN 104/2007]

Voluntary surrender of right to a personalised licence number

39F. (1) If holder of a right to a personalised licence number allocated to a motor vehicle of which the holder is the owner or title holder does not require the right to that personalised licence number, he or she may surrender the right to that personalised licence number.

[The word “the” appears to have been omitted after the opening word “If”.]

(2) The holder of a right to a personalised licence number who in terms of subregulation (1) surrenders the right to the personalised licence number, must notify the appropriate registering authority on the approved form, and the notification must be accompanied by -

- (a) an application referred to in regulation 31, for the licensing of the motor vehicle to which the personalised licence number was allocated; and
- (b) the certificate of entitlement issued in terms of regulation 39(11).

(3) On receipt of the notification and application contemplated in subregulation (2), the appropriate registering authority must, if satisfied that the application is complete -

- (a) forward the notification to the issuing authority;
- (b) licence the motor vehicle in accordance with this Chapter; and
- (c) update the particulars pertaining to personalised licence numbers in the register of motor vehicles referred to in regulation 366(6)(a).

(4) The issuing authority may, from the date of receipt of the notification referred to in subregulation (3), allocate that personalised licence number to any other person who makes an application for the allocation of the personalised licence number in accordance with regulation 38.

[regulation 39F inserted by GN 104/2007]

Annual renewal fee

REGULATIONS
Road Traffic and Transport Act 22 of 1999
Road Traffic and Transport Regulations, 2001

40. (1) A personalised licence number is subject to an annual renewal fee as prescribed in Schedule 1, but if a motor vehicle licence to which a personalised licence number relates becomes void, the annual renewal fee may be refunded to the person who is the owner of that motor vehicle on a pro rata basis.

(2) The annual renewal fee is payable on the anniversary of the date of issue of the certificate of entitlement for the personalised licence number concerned.

(3) Regulation 51 applies with necessary changes to the refund in terms of subregulation (1).

[regulation 40 substituted by GN 104/2007]

Circumstances when personalised number plates become void

41. (1) A personalised licence number becomes void -

- (a) on the expiry of the 90 days referred to in regulation 39A(5);
- (b) on the date on which the motor vehicle to which it relates is deregistered due to that motor vehicle being stolen;
- (c) subject to regulation 39C, 39D, 39E and 39F, on the date of change of an owner or title holder of the motor vehicle to which it relates; or
- (d) 90 days after the annual renewal fee is payable and has not been paid.

(2) The issuing authority may in accordance with this Part reallocate a personalised licence number that has become void in terms of subregulation (1).

(3) A personalised licence number that has become void in terms of subregulation (1)(d) may be reallocated to the owner of the motor vehicle that it relates to if that owner pays the arrears in relation to the annual renewal fee on the date that the motor vehicle licence is renewed.

(4) If a motor vehicle to which a personalised licence number relates is stolen the owner of that motor vehicle must notify the appropriate registering authority, who must update the register of motor vehicles referred to in regulation 366(6)(a), and notify the issuing authority accordingly.

(5) If a motor vehicle is deregistered as a result of it being stolen the personalised licence number in relation to that motor vehicle may not be allocated to another motor vehicle for a period of five years, except where that motor vehicle and that personalised number plate has been recovered and returned to the owner of such motor vehicle.

(6) If the stolen motor vehicle or the personalised number plates or both have been found, the appropriate registering authority must be notified thereof, and the appropriate registering authority must update the register of motor vehicles referred to in regulation 366(6)(a), and notify the issuing authority accordingly.

[regulation 41 substituted by GN 104/2007]

Right of appeal to the Commission in respect of personalised number plates

REGULATIONS
Road Traffic and Transport Act 22 of 1999
Road Traffic and Transport Regulations, 2001

42. (1) A person who is dissatisfied with the refusal of the issuing authority to issue an authorisation for a personalised licence number may, within 21 days from the date that he or she is informed of that refusal, in writing appeal to the Commission against that decision.

(2) A person who is of the opinion that a personalised licence number has been allocated contrary to the provisions of regulation 39(3)(b) or (c), or who has copyright over the expression used as a personalised licence number, may in writing appeal to the Commission against the issue of the personalised licence number.

(3) The person referred to in subregulations (1) and (2) must simultaneously serve a notice of the appeal on the issuing authority.

(4) The issuing authority must, within 14 days of receipt of the notice of appeal, provide the Commission with reasons for the refusal to issue an authorisation to the person contemplated in subregulation (1), and the reason for the allocation of a personalised licence number as contemplated in subregulation (2).

(5) Subject to subregulation (4), the Commission must, within 30 days after receiving the issuing authority's reasons, provide the appellant with its decision and the reasons for such decision.

(6) A decision in terms of subregulation (5) may include an order that the personalised licence number be cancelled, and the person to whom that personalised licence number was allocated must, upon receiving notice of such cancellation, surrender that personalised number plate in accordance with regulation 41.

(7) If the person contemplated in subregulation (6) has paid the annual renewal fee, the issuing authority must refund such fee, on a pro rata basis to such person.

[regulation 42 substituted by GN 104/2007]

Annual renewal of motor vehicle licence

43. (1) The Minister may, if he or she considers it necessary, forward a motor vehicle licence assessment on the approved form, to the postal address of the owner of the motor vehicle, for the renewal of the licence of that motor vehicle.

(2) For the purpose of the renewal referred to in subregulation (1), the owner must submit the assessment referred to in that subregulation to any registering authority and that submission serves as an application for the renewal referred to in subregulation (1).

[subregulation (2) substituted by GN 31/2019]

- (3) The application referred to in subregulation (2) must be accompanied by -
- (a) the appropriate motor vehicle licence fees prescribed in terms of section 18 of the Road Fund Administration Act, 1999;
 - (b) if applicable, the penalties and arrear licence fees referred to in regulations 92 and 94; and
 - (c) if required in terms of section 58 of the Act, a roadworthy certificate.

REGULATIONS
Road Traffic and Transport Act 22 of 1999
Road Traffic and Transport Regulations, 2001

(4) An owner who does not receive the motor vehicle licence assessment referred to in subregulation (1), is not relieved from the obligation to apply for the licensing of the motor vehicle in the manner referred to in regulation 31.

(5) On receipt of an application duly made in accordance with subregulation (2), the registering authority must licence the motor vehicle as contemplated in regulation 32(2).

(6) If a motor vehicle is required to be licensed in terms of this Part, and an application for the renewal of the licence of the motor vehicle is not received, the registering authority may within three months from the date of liability referred to in regulation 0, forward a notice of the failure to apply for the licensing of that motor vehicle, on the approved form, to the owner of the motor vehicle and a copy thereof to the title-holder of the motor vehicle, and that notice may again be forwarded within six months alter the first notice.

Electronic renewal of motor vehicle licence

43A. (1) The renewal of a motor vehicle licence may be done electronically.

(2) For the purpose of the renewal referred to in subregulation (1), the owner must renew the licence by updating his or her details online by accessing the Namibia Traffic Information System through the Roads Authority website and that update serves as an application for the renewal referred to in subregulation (1).

(3) On completion of the process set out in subregulation (2), the owner must pay in the manner provided for on the Roads Authority website -

- (a) the appropriate motor vehicle licence fee imposed in terms of section of the Road Fund Administration Act, 1999 (Act No. 18 of 1999); and
- (b) if applicable, the penalties and arrear licence fees referred to in regulations 92 and 94.

(4) On receipt of the licence information of the motor vehicle as referred to in subregulation (2), the registering authority must license the motor vehicle in the manner contemplated in regulation 32(2).

[regulation 43A inserted by GN 298/2021]

Additional requirements for application for licensing in the case of alteration or reconstruction of registered motor vehicle

44. (1) When a motor vehicle is altered or reconstructed in such a manner and to such an extent that the motor vehicle licence or licence disc issued in respect of the motor vehicle no longer correctly describes that motor vehicle that motor vehicle licence and licence disk becomes void on the date of the completion of the alteration or reconstruction and liability for the licensing of that motor vehicle arises on that date.

[The word disk appears once in subregulation (1) spelt with a "k";
most other uses of the word in these regulations use the spelling "disc".]

REGULATIONS
Road Traffic and Transport Act 22 of 1999
Road Traffic and Transport Regulations, 2001

(2) An application for the licensing of a motor vehicle referred to in subregulation (1), must be made in terms of regulation 31, and in addition to the requirements and documents referred to in that regulation, must be accompanied by -

- (a) a roadworthy certificate;
- (b) a mass measuring certificate referred to in regulation 101; and
- (c) a Police clearance in respect of the motor vehicle.

(3) Subregulation (1) does not apply in respect of a motor vehicle where only the colour is changed or the engine is replaced, but the owner of the motor vehicle must notify the appropriate registering authority of the change or replacement within 21 days after that change or replacement on the approved form and the notification must be accompanied by a Police clearance of the motor vehicle concerned.

(4) On receipt of a notice referred to in subregulation (3), the registering authority must -

- (a) update the particulars pertaining to the motor vehicle concerned in the register of motor vehicles referred to in regulation 366(6)(a); and
- (b) issue a confirmation of the update on the approved form.

(5) For the purposes of this regulation, “colour” means the main colour of the body of a motor vehicle, viewed from the outside.

(6) The registering authority must notify the title-holder of a motor vehicle (if the title-holder and the owner are not the same person) of any reconstruction or alteration of the motor vehicle on the approved form.

Procedure on change of appropriate registering authority due to owner moving

45. If the address of the owner of a motor vehicle changes and the registering authority at whose office the motor vehicle is licensed, is no longer the appropriate registering authority due to the change, the owner of that motor vehicle is liable to apply for the licensing of that motor vehicle in the manner referred to in regulation 31 to the new appropriate registering authority on the date referred to in regulation 30(1)(d).

Procedure on redefining of area of registering authority

46. If a registering authority becomes the new registering authority of an area previously under the jurisdiction of another registering authority, every owner of a licensed motor vehicle for whom the new registering authority becomes the appropriate registering authority, is liable to apply to the new registering authority for the licensing of that motor vehicle in the manner referred to in regulation 31 on the date referred to in regulation 30(1)(d), if that motor vehicle is not licensed with the new registering authority.

Procedure on change of licence mark of registering authority or licence number system

47. (1) If the Minister allocates a new licence mark or licence number system to a registering authority in terms of regulation 34(2), the owner of a motor vehicle licensed at that registering authority is liable to apply to that registering authority for the licensing of the motor

REGULATIONS
Road Traffic and Transport Act 22 of 1999
Road Traffic and Transport Regulations, 2001

vehicle in the manner referred to in regulation 31 and on the date referred to in regulation 30(1)(d).

(2) The Minister may by notice in the *Gazette* extend the date referred to in subregulation (1).

Display of licence number

48. (1) The licence number of a motor vehicle must be displayed on a plate, to be referred to as a number plate, which must comply with the standard specification of the South African Bureau of Standards, 1116 “Retro-reflective Number plates for Motor Vehicles” -

- (a) in the case of a metal plate, Part II - 1982 “Registration plates”, as published by South African Government Notice No. R.463 of 9 July 1982; and
- (b) in the case of a plastics plate, Part IV - 1984 “Registration plates (plastics)” as published by South African Government Notice No. R.1644 of 3 August 1984.

(2) The number plate must bear a standardisation mark as defined in section 1 of the Standards Act, 1982, and as shown in the Standard Specification referred to in subregulation (1) and the colour of the number plate must be as follows:

- (a) For a motor vehicle owned by a member, agent or officer of or a delegate to any public international organisation or institution and registered as being entitled to diplomatic immunity as contemplated in regulation 34(4), all letters and figures must be black and the background of the number plate must be a reflective white colour;
- (b) for a motor vehicle owned by a person, other than a person referred to in paragraph (a), registered as being entitled to diplomatic immunity as contemplated in regulation 34(4), all letters and figures must be white and the background of the number plate must be a reflective red colour;
- (c) for a motor vehicle of which any Government ministry is the owner, other than a motor vehicle referred to in paragraphs (d), (e), (f) or (g), all letters and figures must be white and the background of the number plate must be a reflective green colour;

[paragraph (c) substituted by GN 205/2004]

- (d) for a ceremonial motor vehicle owned by the Government and allocated to the Chief of the Defence Force, there must be three stars of 75 millimetres in diameter each, which must be golden in colour and in design similar to the stars depicting the rank of a general, and the background of the number plate must be a reflective red colour;
- (e) for a ceremonial motor vehicle owned by the Government and allocated to the Army Commander, there must be two stars of 75 millimetres in diameter each, which must be golden in colour and in design similar to the stars depicting the rank of a general, and the background of the number plate must be a reflective green colour;
- (f) for ceremonial motor vehicle owned by the government and allocated -

REGULATIONS
Road Traffic and Transport Act 22 of 1999
Road Traffic and Transport Regulations, 2001

- (i) to the Inspector-General of the Namibian Police, there must be on that number plate -
 - (aa) three, five point stars which are gold in colour and 70 mm in diameter each; and
 - (bb) the background of that number plate must be reflective blue and black, which background must be bordered in red;
- (ii) to the Deputy Inspector-General of the Namibian Police, there must be on that number plate -
 - (aa) two, five point stars which are gold in colour and 70 mm in diameter each; and
 - (bb) the background of that number plate must be reflective blue and black, which background must be bordered in red; and
- (iii) to the Commissioner of the Namibian Police, there must be on that number plate -
 - (aa) one, five point star which is gold in colour and 70 mm in diameter; and
 - (bb) the background of that number plate must be reflective blue and black, which background must be bordered in red;

[paragraph (f) substituted by GN 205/2004 and by GN 130/2018]

- (g) for a motor vehicle not included under paragraph (a), (b), (c), (d) or (e), all letters and figures must be black and the background of the number plate must be a reflective yellow.
- (h) for a ceremonial motor vehicle owned by the Government and allocated to the Commissioner of Prisons, there must be on that number plate the letters “PS”, which letters must be in a golden colour against a reflective red background, which background must be bordered by a thin golden line.

[paragraph (h) inserted by GN 205/2004]

- (3) (a) In the case of a number plate not used under the authority of a motor trade number licence, the letters and figures must be arranged -
 - (i) in the case of a motor vehicle referred to in paragraph (a) or (b) of subregulation (2), either -
 - (aa) with all the letters and figures in one line with three figures preceding a maximum of four letters, followed by two figures and a letter; or
 - (bb) with three figures preceding a maximum of four letters in one line and two figures preceding a letter on the line immediately below;

REGULATIONS
Road Traffic and Transport Act 22 of 1999
Road Traffic and Transport Regulations, 2001

- (ii) in the case of a motor vehicle referred to in paragraph (c) of subregulation (2) -
 - (aa) with all letters and figures in one line, the letters preceding the figures; or
 - (bb) with the letters in one line and the figures in a line immediately below those letters;

[subparagraph (iii) deleted by GN 205/2004]

- (b) In the case of a number plate used under the authority of a motor trade number licence, the figures must precede the letters and all figures and letters must be arranged -
 - (i) in the case of a number plate for a motor vehicle, other than a motorcycle, in one line; and
 - (ii) in the case of a number plate for a motorcycle, with the figures in one line and the letters in a line immediately below.
- (c) In the case of a number plate referred to in subregulation (2)(d) and (e), the stars must be arranged in a horizontal line.

(4) The owner of a motor vehicle must cause the number plate of the motor vehicle to be affixed thereto, from the date of licensing of the motor vehicle, in the manner referred to in subregulation (6), whether or not that motor vehicle is operated on a public road, but this subregulation does not apply in respect of a number plate which is removed from a motor vehicle for the purpose of effecting repairs to the motor vehicle or number plate, and while that motor vehicle is not operated on a public road.

- (5) A person may not operate a motor vehicle on a public road -
 - (a) if a licence number or anything purporting to be a licence number, which is not applicable to the motor vehicle, is displayed thereon;
 - (b) if the licence number is in any way obscured or has become illegible, except if the licence number is temporarily obscured or illegible by reason of a cause beyond the control of the driver of the motor vehicle;
 - (c) while, subject to subregulation (2) -
 - (i) any design appears on the number plate or if the plate is fitted to a number plate holder, on that holder; and
 - (ii) there appears within 150 millimetres of the licence number applicable to that motor vehicle, a design, ornamentation, figure or letter which is not a component part of the standard equipment or construction of that motor vehicle, but this paragraph does not apply to a distinguishing sign of the country of registration affixed in terms of the Convention;
 - (d) which, if the motor vehicle is deemed to be registered and licensed by reason of it being registered or licensed in any country, does not comply with the legislation of

REGULATIONS
Road Traffic and Transport Act 22 of 1999
Road Traffic and Transport Regulations, 2001

that country relating to the registration and licensing of motor vehicles and matters in connection therewith;

- (e) which is registered in any country other than Namibia, without displaying the distinguishing sign of the country of registration allocated in terms of the Convention;
 - (f) if the vehicle is registered in Namibia and displays thereon a distinguishing sign other than the distinguishing sign allocated to Namibia in terms of the Convention; or
 - (g) on which a plate is affixed on which a licence number appears which is not applicable to that motor vehicle or anything purporting to be a licence number.
- (6) A number plate must be affixed -
- (a) in such a manner that it is not easily detached;
 - (b) to the back of a motorcycle or trailer;
 - (c) one to the back and one to the front of all other motor vehicles;
 - (d) in an upright position or within 15 degrees of that position;
 - (e) in such a manner that each letter and figure thereon is clearly legible; and
 - (f) in such a manner that the whole number plate is clearly visible.
- (7) A number plate must, in the case of -
- (a) a double-deck bus of which the engine is at the rear, be affixed not higher than one comma nine metres from ground level; or
 - (b) any other motor vehicle, be affixed not higher than one-comma five metres from ground level.

(8) Subregulation (6) regarding the legibility and visibility of a number plate which is affixed to the back of a motor vehicle, does not apply to a motor vehicle which is towing another vehicle.

Distinguishing sign in terms of Convention

49. (1) The distinguishing sign for a motor vehicle registered in Namibia and taking part in international traffic as contemplated in the Convention must, subject to subregulation (2), be displayed upon the rear end of a motor vehicle and must consist of the capital letters "NAM".

[subregulation (1) substituted by GN 205/2004]

(2) The letters referred to in subregulation (1) must have a height of at least 80 millimetres and their strokes must have a width of at least 10 millimetres.

REGULATIONS
Road Traffic and Transport Act 22 of 1999
Road Traffic and Transport Regulations, 2001

(3) The letters referred to in subregulation (1) must be painted in black on a white background, in the shape of an ellipse with the major axis in a horizontal position.

(4) The dimensions of the axes of the ellipse must -

(a) for a motorcycle, be at least 175 millimetres and 115 millimetres; or

(b) for any other motor vehicle, be at least 240 millimetres and 145 millimetres.

Display of licence disc

50. (1) The owner of a motor vehicle shall display a licence disc issued in respect of the motor vehicle, in the manner referred to in subregulation (2).

(2) A licence disc issued in respect of a motor vehicle must -

(a) if the motor vehicle is fitted with a transparent windscreen, be displayed by affixing it thereon, in an upright position on the inside of the windscreen in such manner that the print on the face of the licence disc is clearly legible from the outside to a person standing in front or to the left front of that vehicle;

(b) if the motor vehicle is not fitted with a transparent windscreen, be affixed in a conspicuous position on the left side of that motor vehicle in such a manner that the print on the face of that certificate is clearly legible from that side; or

(c) if the licence disc is required to be displayed on a motor vehicle in a position where it is exposed to the weather, be protected by affixing that licence disc on the inside of the transparent front of a durable watertight holder.

(3) A person may not operate a motor vehicle on a public road if the licence disc or anything purporting to be a licence disc displays information, which -

(a) does not relate to that motor vehicle;

(b) is obscured or has become illegible, except if that licence disc is temporarily obscured or illegible by reason of a cause beyond the control of the driver of that motor vehicle; or

(c) is invalid.

[subregulation (3) substituted by GN 205/2004]

Procedure for refund of motor vehicle licence fees

51. (1) The owner of a motor vehicle which has -

(a) been reported stolen as referred to in regulation 89(1)(c);

(b) been reported permanently unfit for use as a motor vehicle as referred to in regulation 90(1)(b); or

(c) been deregistered in terms of regulation 24, may apply for a refund of an amount calculated at one twelfth of the motor vehicle licence fees paid in respect of that

REGULATIONS
Road Traffic and Transport Act 22 of 1999
Road Traffic and Transport Regulations, 2001

motor vehicle in terms of regulation 31(2) for every month for which the motor vehicle licence remains valid, on the day immediately preceding the day from which the owner is exempt from liability for licensing of the motor vehicle concerned in terms of regulation 24, 89(6) or 90(4).

(2) The owner of the motor vehicle referred to in subregulation (1) may, within a period not exceeding three years after the date of notification in terms of regulation 89(1)(c) or 90(1)(b) or the date of deregistration, apply to the Minister for a refund of the motor vehicle licence on the approved form.

(3) On receipt of the application referred to in subregulation (2), the Minister must refund the owner of the motor vehicle referred to in subregulation (1), with the amount referred to in that subregulation.

PART 3
MOTOR TRADE NUMBERS

Motor vehicle may be operated under motor trade number under certain circumstances.

52. (1) Notwithstanding anything to the contrary contained in this Chapter, a manufacturer, builder, importer, motor transport contractor or motor dealer may operate a motor vehicle which may not otherwise be operated on a public road, under a motor trade number issued in terms of this Part for the purposes of -

[The word "Notwithstanding" is misspelt in the *Government Gazette*, as reproduced above.]

- (a) delivery of that motor vehicle by a motor transport contractor, in the course of his or her business;
- (b) delivery, sale, exchange, repair or building of a permanent structure of that motor vehicle by a motor dealer;
- (c) delivery or testing by the manufacturer or builder of that motor vehicle;
- (d) delivery of that motor vehicle by an importer; or
- (e) reaching an examiner of vehicles, for the purpose of examination and testing by such examiner of vehicles, or reaching a weighbridge facility.

[subregulation (1) substituted by GN 31/2019]

(2) A banking institution or a person who is a credit grantor in respect of a motor vehicle which -

- (a) is subject to an instalment sale transaction or a leasing transaction; and
- (b) that institution or persons wishes to operate on a public road for the purpose of repossessing that motor vehicle, may, if that motor vehicle may not otherwise be so operated, operate that motor vehicle on a public road under a motor trade number issued in terms of this Part.

(3) A person may not operate a motor vehicle under a motor trade number except for the purposes referred to in this regulation.

REGULATIONS
Road Traffic and Transport Act 22 of 1999
Road Traffic and Transport Regulations, 2001

Manner of application for motor trade number

53. (1) An application for a motor trade number must be made to the appropriate registering authority on an approved form and must be accompanied by -

- (a) acceptable identification of the applicant and, if the applicant is a body of persons, that of his or her proxy and representative and a letter of proxy; and
- (b) the fees prescribed in terms of section 18 of the Road fund Administration Act, 1999, and if applicable, the penalties and arrear fees referred to in regulations 92 and 94.

(2) The applicant referred to in subregulation (1) shall indicate the number of motor trade numbers he or she desires to be issued with, and the purpose for which he or she desires to be issued with those numbers.

Motor trade number system

53A. (1) The Minister may, subject to subregulation (2), establish a motor trade number system by notice in the *Gazette*;

[Subregulation (1) ends with a semicolon instead of a full stop in the *Government Gazette*.]

(2) A motor trade number system established in terms of subregulation (1) shall consist of four figures followed by the letter "N" and the registration mark of the registering authority as contemplated in regulation 34(2).

[regulation 53A inserted by GN 86/2017]

Manner of issue of motor trade number

54. (1) On receipt of the application referred to in regulation 53, the registering authority -

- (a) must satisfy itself that the applicant is entitled to be issued with a motor trade number; and
- (b) may, and if the applicant so requires, must issue an assessment showing the penalties and fees referred to in regulation 53(1)(b), for the issue of a motor trade number.

(2) On payment of the amount shown in the assessment referred to in subregulation (1) the registering authority must, subject to regulation 94(2), and if satisfied that the application is in order -

- (a) record the particulars in relation to the applicant in the register of motor vehicles referred to in regulation 366(6)(a); and
- (b) issue on the conditions as it determines and on the approved form, the number of motor trade number registration certificates applied for.

REGULATIONS
Road Traffic and Transport Act 22 of 1999
Road Traffic and Transport Regulations, 2001

(3) If the application is refused the registering authority must notify the applicant accordingly.

Motor trade number to be licensed

55. Every motor trade number issued in terms of regulation 54 must be licensed by the holder of that motor trade number in accordance with this Part, with the appropriate registering authority.

Date on which motor trade number to be licensed

56. (1) Liability for the licensing of a motor trade number referred to in regulation 55, arises on -

- (a) the date of issue of the motor trade number registration certificate referred to in regulation 54; or
- (b) the first day of the month following the date of expiry of the licence of the motor trade number in terms of regulation 59.

(2) If it is in issue in any civil or criminal proceedings whether an alleged date is the date referred to in subregulation (1), the date so alleged is, until the contrary is proved, deemed to be the date referred to in that subregulation.

Manner of application for licensing of motor trade number

57. (1) The holder of a motor trade number must apply for the licensing of the motor trade number simultaneously with the application and on the same form referred to in regulation 53(1).

(2) The fees prescribed in terms of section 18 of the Road Fund Administration Act, 1999, and if applicable, the penalties and arrear fees referred to in regulations 92 and 94, must accompany the application referred to in subregulation (1).

Manner of licensing of motor trade number

58. (1) On receipt of an application referred to in regulation 57, the registering authority may, and if the applicant so requires, must issue an assessment showing the penalties and fees referred to in regulation 57(2) for the licensing of the motor trade number concerned.

(2) On payment of the amount shown in the assessment referred to in subregulation (1) and if satisfied that the application is in order, the registering authority must, subject to regulation 94(2) -

- (a) licence the motor trade number;
- (b) update the particulars in relation to the motor trade number concerned in the register of motor vehicles referred to in regulation 366(6)(a);
- (c) issue a motor trade number licence on the approved form; and

REGULATIONS
Road Traffic and Transport Act 22 of 1999
Road Traffic and Transport Regulations, 2001

- (d) subject to regulation 60(5), issue a motor trade number licence disc on the approved form, which must be completed in black non-fading ink, as proof of the possession of the motor trade number licence.

Period of validity of motor trade number licence and motor trade number licence disc

59. A motor trade number licence and motor trade number licence disc are valid for a period of 12 months from the first day of the month in which it is issued and the date of expiry of that motor trade number licence must be shown on the motor trade number licence and the motor trade number licence disc, but if the holder of the motor trade number applies for the renewal of the current motor trade number licence and motor trade number licence disc in terms of regulation 60(2) before the expiry date of that licence and licence disc, the period of validity of the new licence and licence disc must be calculated from the first day of the month which follows on the expiry date of the current licence and licence disc.

Annual renewal of motor trade number licence

60. (1) The Minister may, if he or she considers it necessary, forward a motor trade number licence assessment to the postal address of the holder of a motor trade number, on the approved form for the renewal of the licence of that motor trade number.

(2) For purpose of the renewal referred to in subregulation (1), the holder must submit the assessment together with the penalties and fees referred to in regulation 57(2), to the appropriate registering authority and that submission serves as an application for the renewal of the motor trade number licence.

[The phrase “For purpose of” should be “For the purpose of” or “For purposes of”.]

(3) The registering authority must, on payment of the fees referred to in subregulation (2), and if the application is in order, licence the motor trade number as contemplated in regulation 58(2).

(4) The holder of a motor trade number who does not receive the assessment contemplated in subregulation (1), is not relieved from the obligation to apply for the licensing thereof in the manner referred to in regulation 57.

(5) Notwithstanding anything to the contrary contained in this Part and subject to regulation 64, an expired motor trade number and an expired motor trade number licence disc may, as from the date of expiry referred to in regulation 59, be displayed for a grace period of 21 days as contemplated in regulation 95.

[subregulation (5) substituted by GN 205/2004]

(6) The cancellation of a motor trade number in terms of subregulation (5), does not exempt the person who held the motor trade number from the liability for the payment of the penalties and arrear licence fees referred to in regulations 92 and 94.

Procedure for change of particulars of holder of motor trade number

61. (1) If the postal or street address, the proxy or the representative of the holder of a motor trade number changes, that holder must, within 21 days after that change, notify the appropriate registering authority of that change on the approved form.

REGULATIONS
Road Traffic and Transport Act 22 of 1999
Road Traffic and Transport Regulations, 2001

(2) If the name or identification number as reflected in the acceptable identification of the holder of a motor trade number changes, that holder must, within 21 days from the change -

- (a) notify the appropriate registering authority of the change on the approved form;
- (b) submit the new acceptable identification; and
- (c) submit every motor trade number registration certificate issued to him or her.

(3) Where the proxy or representative of the holder of a motor trade number changes, the acceptable identification of the new proxy or representative and a new letter of proxy must accompany the notice referred to in subregulation (1).

(4) If on request of the notification referred to in subregulation (1) or (2), the registering authority is satisfied that the notification is in order, it must -

- (a) update the particulars in relation to the person or body of persons concerned in the register of motor vehicles referred to in regulation 366(6)(a);
- (b) issue an acknowledgment receipt of the notification on the approved form; and

[The word “of” appears to have been omitted between “acknowledgment” and “receipt”.]

- (c) in the case of a notification in terms of subregulation (2), issue a new motor trade number registration certificate to the holder upon payment of the fees prescribed in terms of section 18 of the Road Fund Administration Act, 1999 for the issue of a duplicate document.

(5) If a motor trade number is held by a partnership and one of the partners dies or ceases to be a partner of the partnership or a new partner is admitted thereto or if a person obtains from the estate of a deceased spouse the business of -

- (a) motor transport contractor;
- (b) manufacturer;
- (c) builder;
- (d) importer;
- (e) motor dealer; or
- (f) banking institution,

and a motor trade number is in force in respect of that business, every such number, notwithstanding any provisions to the contrary contained in this Part, remains in force for the unexpired period of the motor trade number licence concerned, in respect of that business and the new owner of the business is deemed to be the holder of the motor trade number.

Cancellation of motor trade number

62. (1) If the holder of a motor trade number has, in the opinion of the Minister, contravened a provision of this Chapter in the course of carrying on the business of a motor

REGULATIONS
Road Traffic and Transport Act 22 of 1999
Road Traffic and Transport Regulations, 2001

transport contractor, manufacturer, builder, importer, motor dealer or banking institution referred to in regulation 52(2), as the case may be, the Minister may cancel the motor trade number of that holder.

(2) If a motor trade number is cancelled in terms of subregulation (1), the holder of that number must forthwith surrender the motor trade number registration certificate, motor trade number licence, motor trade number licence disc and the plate referred to in regulation 64 to the appropriate registering authority for the destruction thereof.

(3) The holder of a motor trade number who -

- (a) no longer requires that number; or
- (b) ceases to carry on the business referred to in subregulation (1), must forthwith apply to the appropriate registering authority on the approved form for the cancellation of that motor trade number and the relevant motor trade number registration certificate, motor trade number licence, motor trade number licence disc and the plate referred to in regulation 64 must accompany the application.

(4) On receipt of the application referred to in subregulation (3), the registering authority must -

- (a) cancel the motor trade number;
- (b) deface the motor trade number registration certificate and the motor trade number licence;
- (c) destroy the motor trade number licence disc and plate; and
- (d) update the particulars pertaining to the motor trade number in the register of motor vehicles referred to in regulation 366(6)(a) accordingly.

Number issued in any country

63. A number which has a similar purpose to that of a motor trade number, and which is issued in any country in accordance with the laws of that country, is deemed to be a motor trade number for the purposes of this Part when that number is displayed on a motor vehicle which is operated on a public road in Namibia.

Display of motor trade number and motor trade number licence disc

64. (1) A motor trade number must be displayed on a plate referred to in regulation 48 and in accordance with that regulation, but in the case of a motor vehicle, other than a motorcycle or trailer, that plate must -

- (a) if the motor vehicle has a rear window, be displayed on the inside of that window in an upright position so that each letter and figure of the plate is clearly legible when viewed from the rear of the motor vehicle; or
- (b) if the motor vehicle has no rear window or the rear window is too small to display the motor trade number, be displayed on the rear end of the motor vehicle in an upright position so that each letter and figure of that plate is clearly legible when viewed from the rear of the motor vehicle.

REGULATIONS
Road Traffic and Transport Act 22 of 1999
Road Traffic and Transport Regulations, 2001

(2) A motor trade number licence disc issued in terms of regulation 58, must be affixed to the inside of the transparent front of a durable watertight holder.

(3) The watertight holder referred to in subregulation (2), must be attached to the plate so referred to in subregulation (1) that the print on the face of the motor track number licence disc is clearly legible as contemplated in subregulation (1).

(4) A motor trade number may not be permanently affixed to any motor vehicle.

Right of appeal to Minister

65. (1) Any person who is aggrieved by the refusal of a registering authority to issue a motor trade number to him or her in terms of regulation 54, may, within 21 days after the date of the refusal, in writing appeal against the refusal to the Minister and that person must at the same time serve a copy of the appeal on the registering authority concerned.

(2) On receipt of the copy of the appeal referred to in subregulation (1), the registering authority concerned must forthwith furnish the Minister with reasons for the refusal to which the appeal relates.

(3) For the purpose of deciding an appeal referred to in subregulation (1), the Minister may require each party to the appeal to furnish the information and evidence, as he or she considers necessary.

(4) The Minister may, after considering the appeal, give such decision as he or she considers appropriate.

PART 4
TEMPORARY AND SPECIAL PERMITS

Circumstances in which motor vehicle may be operated on public road under temporary or special permit

66. (1) A person who desires to operate, on a public road, a motor vehicle which is not registered and licensed and which may not otherwise be so operated, may -

(a) if he or she is the owner of the motor vehicle, obtain a temporary permit in respect of that motor vehicle in order to operate that motor vehicle on a public road as if it is registered and licensed, if it is to be -

(i) delivered by or to the owner, who is a motor dealer; or

(ii) registered and licensed in terms of this Chapter, but only during the period permitted for that registration and licensing; or

(b) obtain a special permit in respect of the motor vehicle in order to operate it on a public road as if it is registered and licensed for purposes of -

(i) testing the motor vehicle by a manufacturer or builder;

(ii) proceeding to or returning from a place where repairs are to be or have been effected to the motor vehicle;

REGULATIONS
Road Traffic and Transport Act 22 of 1999
Road Traffic and Transport Regulations, 2001

- (iii) reaching an examiner of vehicles or weighing device; or
- (iv) repossessing the motor vehicle as contemplated in regulation 52(2).
- (v) reaching the port of exit, in respect of foreign vehicles in transit.

[Subparagraph (v) is inserted by GN 2/2008. The amendment should have accordingly deleted “or” from the end of subparagraph (iii) and changed the full stop at the end of subparagraph (iv) to a semi-colon followed by the word “or”.]

- (2) A temporary permit -
 - (a) may not be issued in respect of a motor vehicle referred to in regulation 153(1) unless a roadworthy certificate in respect of the motor vehicle is submitted;
 - (b) may not be issued to a motor vehicle that must be licensed in terms of this Chapter unless a copy of the application for the licensing of the motor vehicle is submitted;
 - (c) which is blank, may only be issued to a motor dealer.

(3) The owner of a motor vehicle which is licensed and who cannot comply forthwith with regulation 39, 48 or 50, may obtain a temporary permit in order to operate the motor vehicle on a public road.

[subregulation (3) amended by GN 104/2007]

(4) A special permit does not authorise the holder of the permit to convey persons or goods in the motor vehicle concerned.

Manner of application for temporary or special permit

67. (1) A motor dealer who requires a series of blank temporary permits must apply to the appropriate registering authority on the approved form.

(2) If a temporary or special permit is required for a motor vehicle, the application for such permit must be made to the appropriate registering authority on the approved form, but if a motor vehicle is obtained from a motor dealer, the owner of the motor vehicle may obtain a temporary permit from the motor dealer.

- (3) An application referred to in subregulation (1) or (2), must be accompanied by -
 - (a) the acceptable identification of the applicant, and if the applicant is a body of persons, that of its proxy and representative and a letter of proxy
 - (b) the appropriate fees prescribed in terms of section 18 of the Road Fund Administration Act, 1999, and if applicable, the penalties and arrear fees referred to in regulations 92 and 94; and
 - (c) in the case of motor vehicles referred to in regulation 66(2)(a), a roadworthy certificate.

Temporary or special permit number system

REGULATIONS
Road Traffic and Transport Act 22 of 1999
Road Traffic and Transport Regulations, 2001

68. A temporary or special permit number system must comprise of the letter “N” followed by the licence mark of the registering authority as contemplated in regulation 34(2) and followed by six figures and the letter “P”, but where the licence mark of the registering authority concerned ends with the letter “O” the figure following the licence mark may not be the number zero.

[regulation 68 substituted by GN 205/2004]

Manner of issue of temporary or special permit

69. (1) On receipt of the application referred to in regulation 67(1) or (2), the registering authority may, and if the applicant so requires, must issue an assessment showing the penalties and arrear fees referred to in regulation 67(3)(b).

(2) On submission of the assessment and upon payment of the fees and penalties referred to in subregulation (1), the registering authority must, subject to regulation 94(2), and if satisfied that the application is in order -

- (a) record the particulars pertaining to -
 - (i) the applicant; and
 - (ii) if applicable, the date, number and place of issue of a roadworthy certificate referred to in regulation 67(3)(c), in the register of motor vehicles referred to in regulation 366(6)(a); and
- (b) issue a series of blank temporary permits or a duly completed temporary or special permit, as the case may be, on the approved form.

(3) The motor dealer referred to in regulation 67(2) must upon payment of the appropriate fees referred to in regulation 67(3)(b) -

- (a) complete the temporary permit and counterfoil on the approved form;
- (b) issue the temporary permit to the owner of the motor vehicle concerned and retain the counterfoil; and
- (c) if applicable, record the date, number and place of issue of a roadworthy certificate referred to in regulation 67(3)(c), on the counterfoil.

(4) A permit issued in respect of a motor vehicle in any country in terms of any law relating to motor vehicles in force in that country and serving the same purpose as a temporary or special permit is, if the provisions of the law of that country relating to the operation of a motor vehicle on a public road under such permit is complied with, deemed to be a temporary permit or special permit issued under this Part.

[The phrase “is complied with” should be “are complied with”
to accord with the subject “provisions”.]

- (5) A motor dealer may not -

REGULATIONS
Road Traffic and Transport Act 22 of 1999
Road Traffic and Transport Regulations, 2001

- (a) issue a temporary permit which has not been issued to that motor dealer in terms of subregulation (2)(b); or
- (b) issue more than one temporary permit to the same person in respect of the same motor vehicle, unless a further temporary permit is necessitated by administrative failure.

[subregulation (5) substituted by GN 205/2004]

(6) A registering authority may, at any time after reasonable notice to a motor dealer, order that all unused temporary permits be returned, or the dealer may return such permits, and must refund that motor dealer for the unused permits not issued by him or her.

(7) A registering authority may not issue more than two temporary or special permit to the same person in respect of the same motor vehicle, unless a further temporary or special permit is necessitated by administrative failure.

[Subregulation (7) is substituted by GN 205/2004 and amended by GN 104/2007. The word “permit” in the phrase “two temporary or special permit” should be plural to be grammatically correct.]

Period of validity of temporary and special permit

70. (1) The date of commencement and the date of expiry of a temporary permit or special permit must be recorded on that permit and that permit is valid -

- (a) in the case of a temporary permit, for a period of 21 days, calculated -
 - (i) in respect of a motor vehicle referred to in regulation 66(3), from the date of issue of the temporary permit; or
 - (ii) for any other motor vehicle, from the date on which liability for the licensing of the motor vehicle arises; or
- (b) in the case of a special permit, for a period of three days calculated from the date specified by the applicant in the application form, but that the date may not be more than seven days after the date on which the application is made.

[The word “the” in the phrase “that the date” is superfluous.]

(2) Subregulation (1) does not apply to blank temporary permits issued to a motor dealer in terms of regulation 69(2)(b).

Display of temporary or special permit

- 71.** (1) A temporary permit or special permit must be displayed -
- (a) if the motor vehicle has a rear window, on the inside of the window in the lower left-hand corner in such a position that, when viewed from the rear of the motor vehicle, the inscription thereon is legible through the glass; or
 - (b) if the motor vehicle does not have a rear window, on the rear of the motor vehicle in a conspicuous place.

REGULATIONS
Road Traffic and Transport Act 22 of 1999
Road Traffic and Transport Regulations, 2001

(2) A person may not operate on a public road a motor vehicle on which a temporary or special permit or anything purporting to be such a permit, which is not applicable to such motor vehicle, is displayed.

(3) A person may not operate on a public road a motor vehicle on which a temporary or special permit is displayed which is in any way obscured or has become illegible, except if that permit is temporarily obscured or illegible by reason of a cause beyond the control of the driver of the motor vehicle.

Duty of motor dealer in respect of temporary permit

72. A motor dealer must -

- (a) in respect of every temporary permit issued by the motor dealer to an applicant in terms of regulation 69(3)(b), keep a record by means of the completed counterfoil of the name and address of the applicant, as well as, if applicable, of the date, number and place of issue of a roadworthy certificate; and
- (b) within 14 days after the date of issue of the tenth permit in a book, return to the appropriate registering authority every book of counterfoils so completed.

PART 5
REGISTRATION OF MANUFACTURERS, BUILDERS, IMPORTERS
AND NUMBER PLATE MANUFACTURERS

Manner of application for registration of manufacturer, builder or importer

73. (1) An application in terms of section 21(1) of the Act must be made on the approved form.

- (2) An application referred to in subregulation (1) must be accompanied by -
- (a) the acceptable identification of the applicant and, if that applicant is a body or persons, that of its proxy and representative and a letter of proxy;
 - (b) the appropriate fees contemplated in Schedule 1;
 - (c) in the case of an importer of motor vehicle, the customs activity number issued to the applicant by the Ministry responsible for Customs and Excise; and
 - (d) any other additional information or documents as may be required by the Minister.

Manner of registration of manufacturer, builder or importer

74. (1) On receipt of an application referred to in regulation 73, the Minister must -

- (a) ensure that the application is in order;
- (b) require the inspectorate of manufacturers, builders, importers and number plate manufacturers to -
 - (i) evaluate the applicant in respect of the compliance of the vehicles manufactured, built, modified or imported by the applicant, with the relevant

REGULATIONS
Road Traffic and Transport Act 22 of 1999
Road Traffic and Transport Regulations, 2001

legislation, standards, specifications and codes of practise applicable in respect of motor vehicles determined by the Minister; and

- (ii) submit a recommendation in respect of the registration of the applicant:
 - (c) require the Namibian Police to submit a report in respect of the applicant, and the report may contain any prior convictions recorded against the applicant and the nature of those convictions, and any such official is hereby authorised to report accordingly; and
 - (d) with due regard to the evaluation and recommendations of the inspectorate of manufacturers, builders, importers and number plate manufacturers and the Namibian Police, satisfy himself or herself that the applicant is suitable to be registered.
- (2) If the Minister is satisfied in terms of subregulation (1)(d), he or she must -
- (a) register the applicant subject to any or all of the conditions as prescribed in regulation 75 and, if he or she considers it necessary, such additional conditions as determined by him or her;
 - (b) record the particulars pertaining to the applicant, on the register of manufacturers, builders and importers referred to in regulation 366(1)(a)(iii); and
 - (c) issue to the applicant a certificate of registration on the approved form, which must reflect the conditions referred to in paragraph (a).
- (3) If the Minister is not satisfied that the applicant may be registered as a manufacturer, builder or importer, he or she must notify that applicant accordingly.
- (4) A registered manufacturer, builder or importer of motor vehicles is, at any reasonable time, subject to an evaluation by the inspectorate of manufacturers, builders, importers and number plate manufacturers.

Conditions upon which manufacturer, builder or importer may be registered

- 75.** The Minister -
- (a) shall require as a condition of registration that -
 - (i) notice be given by the manufacturer, builder or importer concerned on the approved form to the inspectorate of manufacturers, builders, importers and number plate manufacturers of any motor vehicle being manufactured, built or imported; and
 - (ii) a model number referred to in regulation 82(1)(c) be obtained and held by manufacturers, builders or importers for all models of motor vehicles being manufactured, built, modified or imported;
 - (b) may require as a condition of registration that -

REGULATIONS
Road Traffic and Transport Act 22 of 1999
Road Traffic and Transport Regulations, 2001

- (i) a motor vehicle manufactured, built, modified or imported by a manufacturer, builder or importer, must be presented to the Namibian Police for clearance of the motor vehicle;
- (ii) a roadworthy certificate be obtained for every model of a motor vehicle; or
- (iii) both the conditions referred to in subparagraphs (i) and (ii) be complied with.

Manner of suspension or cancellation of registration of manufacturer, builder or importer

76. (1) If the inspectorate of manufacturers, builders, importers and number plate manufacturers finds that a manufacturer, builder or importer does not comply with his or her conditions of registration, the inspectorate must recommend to the Minister the suspension or cancellation of the registration of that manufacturer, builder or importer.

(2) The Minister shall, in considering the suspension or cancellation of the registration of a manufacturer, builder or importer -

- (a) notify the manufacturer, builder or importer concerned; and
- (b) inform the manufacturer, builder or importer concerned that he or she may submit to the Minister, within 14 days after that notification, any aspect that may be taken into account in considering the suspension or revocation.

(3) If the Minister suspends or cancels the registration of a manufacturer, builder or importer in terms of section 22 of the Act, he or she must notify the manufacturer, builder or importer of that suspension or cancellation and the reason therefore and, in the case of suspension, the period thereof.

(4) If the registration of a manufacturer, builder or importer is cancelled, that manufacturer, builder or importer must within 14 days after having been notified of the cancellation, submit the certificate of registration issued in terms of regulation 74(2)(c), to the Minister.

Number plate manufacturer must register

77. A person may not manufacture or sell a number plate unless he or she is registered as a number plate manufacturer in terms of these regulations.

Manner of application for and registration of number plate manufacturer

78. (1) An application for registration as a number plate manufacturer in terms of section 21 (1) of the Act must be made to the Minister on the approved form.

- (2) An application referred to in subregulation (1) must be accompanied by -
 - (a) the acceptable identification of the applicant and, if the applicant is a body of persons, that of his or her proxy and representative and a letter of proxy;
 - (b) the appropriate fees contemplated in Schedule 1; and
 - (c) any other additional information or documents as may be required by the Minister.

REGULATIONS
Road Traffic and Transport Act 22 of 1999
Road Traffic and Transport Regulations, 2001

- (3) On receipt of an application referred to in subregulation (1), the Minister must -
- (a) ensure that the application is in order;
 - (b) require the inspectorate of manufacturers, builders, importers and number plate manufacturers to -
 - (i) evaluate the applicant in respect of the compliance of the number plates manufactured with regulation 79; and
 - (ii) submit a recommendation in respect of the registration of the applicant;
 - (c) require the Namibian Police to submit a report in respect of the applicant, and the report may contain any prior convictions recorded against the applicant and the nature of those convictions, and any such of official is hereby authorised to report accordingly; and

[The word “of” in the phrase “such of official” is superfluous.]

- (d) with due regard to the evaluation and recommendations of the inspectorate of manufacturers, builders, importers and number plate manufacturers and the Namibian Police, satisfy himself or herself that the applicant is suitable to be registered.
- (4) If the Minister is satisfied in terms of subregulation (1)(d), he or she must -
- (a) register the applicant subject to the conditions prescribed in regulation 79, and if he or she considers it necessary, such additional conditions as determined by him or her;
 - (b) record the particulars pertaining to the applicant on the register of number plate manufacturers referred to in regulation 366(1)(a)(iv); and
 - (c) issue to the applicant a certificate of registration on the approved form, which must reflect the conditions referred to in paragraph (a).

(5) If the Minister is not satisfied that the applicant may be registered as a number plate manufacturer, he or she must notify that applicant accordingly.

(6) A registered number plate manufacturer is, at any reasonable time, subject to an evaluation by the inspectorate of manufacturers, builders, importers and number plate manufacturers.

Conditions for registration as number plate manufacturer

79. (1) Number plates manufactured by a number plate manufacturer must comply with the requirements of the standard specification of the South African Bureau of Standards, SABS 1116: “Retro-reflective Registration Plates for Motor Vehicles”, Part 2: 1996 “Registration plates (metal)” and Part 4: 1996 “Registration plates (plastics)”, as published by the South African Government Notice No. R.463 of 9 July 1982 or R.1644 of 3 August 1984.

REGULATIONS
Road Traffic and Transport Act 22 of 1999
Road Traffic and Transport Regulations, 2001

(2) Number plate manufacturers must keep a register of number plates manufactured, which register must contain -

- (a) the licence number brought onto the number plate concerned;
- (b) the date of manufacture of the number plate;
- (c) the chassis number and engine number of the vehicle to which the number plate concerned is fitted;
- (d) the acceptable identification of the person to whom the number plate concerned is sold; and
- (e) such additional information as required by the Minister.

(3) The register of number plates must be at the disposal of any traffic officer, upon request.

(4) A number plate manufacturer may only use such materials and processes in the manufacture of number plates as are approved by the South African Bureau of Standards and for which test reports are held on the premises of that number plate manufacturer.

(5) The certificate of registration issued to a number plate manufacturer in terms of regulation 78(4)(c) must be displayed in a conspicuous position on the premises of the number plate manufacturer in such a manner that it is visible to members of the public.

Manner of suspension or cancellation of registration of number plate manufacturer

80. (1) If the inspectorate of manufacturers, builders, importers and number plate manufacturers finds that a number plate manufacturer does not comply with his or her conditions of registration, the inspectorate must recommend to the Minister the suspension or cancellation of the registration of that number plate manufacturer.

(2) The Minister shall, in considering the suspension or cancellation of the registration of a number plate manufacturer -

- (a) notify the number plate manufacturer concerned; and
- (b) inform the number plate manufacturer concerned that he or she may submit to the Minister, within 14 days after that notification, any aspect that may be taken into account in considering the suspension or revocation.

(3) If the Minister suspends or cancels the registration of a number plate manufacturer, he or she must notify the number plate manufacturer of that suspension or cancellation and the reason therefor and, in the case of suspension, the period thereof.

(4) If the registration of a number plate manufacturer was cancelled, the number plate manufacturer must, within 14 days after having been notified of the cancellation, submit the certificate of registration issued in terms of regulation 78(4)(c) to the Minister.

Duties of manufacturer, builder or importer who are not required to register

REGULATIONS
Road Traffic and Transport Act 22 of 1999
Road Traffic and Transport Regulations, 2001

81. (1) Any manufacturer or builder who modifies motor vehicles or any importer, who is not required to register in terms of these regulations, must apply to the inspectorate of manufacturers, builders, importers and number plate manufacturers for a letter of authority on the approved form, in respect of any motor vehicle design or any design of a motor vehicle modification, being manufactured, modified or imported, except in respect of a trailer with a gross vehicle mass not exceeding 750 kilograms.

(2) Despite anything to the contrary contained in these regulations, motor vehicles manufactured, built, modified or imported based on any design contemplated in subregulation (1), by any manufacturer, builder or importer, referred to in subregulation (1), may not be registered unless the manufacturer, builder or importer holds a letter of authority for that design.

(3) A motor vehicle manufactured, modified or imported by a manufacturer, builder or importer referred to in subregulation (1) must be presented to the Namibian Police for clearance of that motor vehicle and a roadworthy certificate must be obtained for every such motor vehicle prior to registration.

Powers and duties of inspectorate of manufacturers, builders, importers and number plate manufacturers

82. (1) The inspectorate of manufacturers, builders, importers and number plate manufacturers -

- (a) must, in terms of regulation 74(1)(b) or 78(3)(b), evaluate a manufacturer, builder, importer or number plate manufacturer and make a recommendation to the Minister regarding -
 - (i) the suitability of the manufacturer, builder, importer or number plate manufacturer to be registered: and
 - (ii) the conditions upon which the manufacturer, builder, importer or number plate manufacturer should be registered;
- (b) must, in respect of every manufacturer, builder, importer or number plate manufacturer, conduct inspections to monitor the adherence to relevant legislation, standards, specifications and codes of practice by every manufacturer, builder, importer or number plate manufacturer;
- (c) may advise any manufacturer, builder, importer or number plate manufacturer in writing on the improvement and maintenance of standards applied by the manufacturer, builder, importer or number plate manufacturer concerned and submit a copy of such written advice to the Minister;
- (d) must, when necessary, recommend to the Minister the suspension, cancellation or change in conditions of the registration of a manufacturer, builder, importer or number plate manufacturer;
- (e) if models of motor vehicles being manufactured, built, modified or imported comply with the relevant legislation, standards, specifications and codes of practice for motor vehicles as determined by the Minister must, subject to subregulation (3), issue such models of motor vehicles with a model number; and

REGULATIONS
Road Traffic and Transport Act 22 of 1999
Road Traffic and Transport Regulations, 2001

(f) may suspend or cancel the model number of models of motor vehicles in the event of such models not continuing to comply with the relevant legislation, standards, specifications and codes of practice for motor vehicles as determined by the Minister.

(2) A person employed by, or who acts on behalf of the inspectorate of manufacturers, builders, importers and number plate manufacturers, may at any reasonable time -

(a) for the purposes of evaluating a manufacturer, builder, importer or number plate manufacturer and making a recommendation as contemplated in subregulation (1)(a), inspect, examine or test any motor vehicle which is being manufactured, built, modified or imported by a manufacturer, builder or importer or any number plate which is being manufactured by a number plate manufacturer: and

(b) without prior notice -

(i) enter the premises of any manufacturer, builder, importer or number plate manufacturer;

(ii) inspect records of the manufacturer, builder, importer or number plate manufacturer; and

(iii) question any person with regard to any matter relating to the operation of the manufacturer, builder, importer or number plate manufacturer.

Fee to defray expenditure incurred by inspectorate of manufacturers, builders, importers and number plate manufacturers

83. (1) A manufacturer, builder, importer or number plate manufacturer must upon being registered as such, pay the appropriate fee contemplated in Schedule 1, to the inspectorate of manufacturers, builders, importers and number plate manufacturers, and thereafter such amount is so payable yearly upon the anniversary or the date of registration.

(2) A manufacturer, builder or importer not required to be registered in terms of these regulations must pay the appropriate fee contemplated in Schedule 1 per motor vehicle design or design of motor vehicle modification of which the inspectorate of manufacturers, builders, importers and number plate manufacturers is notified in terms of regulation 81(1).

(3) The inspectorate of manufacturers, builders, importers and number plate manufacturers must not later than 1 June of each year, submit to the Permanent Secretary a statement of fees received and costs incurred by or on behalf of the inspectorate, for the period 1 April to 31 March.

Procedure for change of particulars of manufacturer, builder, importer or number plate manufacturer

84. (1) If there is any change of name, street or postal address, proxy, representative or acceptable identification of a registered manufacturer, builder, importer or number plate manufacturer, that manufacturer, builder, importer or number plate manufacturer must, within 21 days after the date of that change, notify the Minister of that change, on the approved form.

(2) On receipt of the notification referred to in subregulation (1), the Minister shall update the particulars pertaining to that manufacturer, builder, importer or number plate

REGULATIONS
Road Traffic and Transport Act 22 of 1999
Road Traffic and Transport Regulations, 2001

manufacturer in the register of manufacturers, builders and importers referred to in regulation 366(1)(a)(iii), or the register of number plate manufacturers referred to in regulation 366(1)(a)(iv), as the case may be.

Manner of change of conditions on which manufacturer, builder, importer or number plate manufacturer is registered

85. (1) The Minister shall notify a manufacturer, builder, importer or number plate manufacturer of any intention to change the conditions on which the manufacturer, builder, importer or number plate manufacturer is registered, and of the extent of the change.

(2) Within 21 days after receipt of the notification referred to in subregulation (1), the manufacturer, builder, importer or number plate manufacturer concerned may make a written representation to the Minister.

(3) The Minister shall consider any representation made in terms of subregulation (2).

(4) When the conditions referred to in regulation 74(2)(a) or 78(4)(c), change -

(a) the Minister must notify the manufacturer, builder or importer concerned of the change; and

(b) the manufacturer, builder or importer concerned must within 14 days after the change submit to the Minister the certificate of registration referred to in regulation 74(2)(c) or 78(4)(c), as the case may be.

(5) On receipt of the certificate of registration, the Minister shall issue to the manufacturer, builder or importer concerned a new certificate of registration on the approved form, which must reflect the new conditions.

PART 6
GENERAL

Procedure for change of particulars of title-holder or owner of registered motor vehicle

86. (1) If the postal or street address, proxy or representative of the title-holder or owner of a motor vehicle which is registered or licensed in terms of these regulations, changes, that title-holder or owner must, within a period of 21 days after that change, notify the appropriate registering authority of the change on the approved form.

(2) If the name or identification number as reflected in the acceptable identification of the title-holder or owner of a motor vehicle registered in terms of these regulations changes, that title-holder or owner must within a period of 21 days after that change -

(a) notify the appropriate registering authority of the change on the approved form; and

(b) submit the new acceptable identification to it.

(3) Where a change referred to in subregulation (2) occurs in respect of a title-holder, that title-holder must submit every registration certificate issued to him or her, together with the notification referred to in that subregulation, to the appropriate registering authority.

REGULATIONS
Road Traffic and Transport Act 22 of 1999
Road Traffic and Transport Regulations, 2001

(4) The notification referred to in subregulation (1) in respect of a change of the proxy or representative of a body of persons, must be accompanied by the acceptable identification of the new proxy or representative, as the case may be and, if applicable, a letter of proxy.

(5) On receipt of the notification referred to in subregulation (1) or (2), the registering authority must, if it is satisfied that the notification is in order -

- (a) update the particulars pertaining to the person or body of persons concerned in the register of motor vehicles referred to in regulation 366(6)(a);
- (b) issue an acknowledgement of receipt of the notification on the approved form; and
- (c) in the case of a notification referred to in subregulation (2), issue a new registration certificate to the title-holder concerned, on payment of the fees prescribed in terms of section 18 of the Road Fund Administration Act, 1999, for the issue of a duplicate document.

(6) The owner of a motor vehicle must notify the title-holder of that motor vehicle of any change of address or particulars of the owner as referred to in subregulations (1) and (2).

Duty of title-holder and owner of motor vehicle where that title-holder or owner changes

87. (1) A person may not, either for himself or herself or on behalf of another person -

- (a) dispose of or deliver a motor vehicle in terms of an instalment sale transaction or leasing transaction unless that motor vehicle, if required to be registered and licensed in terms of Parts 1 and 2 of this Chapter, is so registered and licensed; and
- (b) acquire or take delivery of a motor vehicle if the motor vehicle may not be disposed of or delivered in terms of paragraph (a).

(2) If there is a change of title-holder of a motor vehicle the current title-holder of that motor vehicle must -

- (a) complete the relevant portion of the approved form;
- (b) ensure that the new title-holder completes the relevant portion of the approved form;
- (c) forthwith forward the approved form to the appropriate registering authority; and
- (d) hand over the registration certificate concerned to the new title-holder.

(3) If there is a change of owner of a motor vehicle, the current owner of the motor vehicle must notify the registering authority where that motor vehicle is licensed of that change, on the approved form.

(4) If, on receipt the notification referred to in subregulation (2) or (3), the registering authority is satisfied that the notification is in order, it -

[The word "of" appears to have been omitted between "on receipt" and "the notification".]

REGULATIONS
Road Traffic and Transport Act 22 of 1999
Road Traffic and Transport Regulations, 2001

- (a) must update the particulars pertaining to the motor vehicle concerned in the register of motor vehicles referred to in regulation 366(6)(a); and
- (b) may acknowledge receipt of that notification on the approved form.

Procedure in case of dispute in relation to appropriate registering authority

88. (1) If a dispute arises between two or more registering authorities or between a person and a registering authority, as to which registering authority is the appropriate registering authority, the Minister must decide that dispute and his or her decision is final.

(2) If it is in issue in any civil or criminal proceeding whether an alleged registering authority is the appropriate registering authority, the alleged registering authority is deemed to be the appropriate registering authority until the contrary is proved.

Procedure if motor vehicle is stolen

89. (1) If a motor vehicle is stolen, the owner of the motor vehicle must -

- (a) report the theft to the Namibian Police, within 24 hours after he or she becomes aware of the theft;
- (b) notify the title-holder forthwith of the theft; and
- (c) within seven days after the date whereupon he or she has become aware of the theft, if the motor vehicle has not been recovered during that period, notify the appropriate registering authority of the theft, by forwarding the approved form to that registering authority.

(2) The Namibian Police and if applicable, the registering authority, must on receipt of the notification referred to in subregulation (1), update the register of motor vehicles accordingly.

(3) A change of title-holder or owner of a motor vehicle reported stolen may only be effected if the change results from -

- (a) an agreement of indemnity against the theft of the motor vehicle; or
 - (b) an agreement between the owner and the title-holder of that motor vehicle.
- (4) The title-holder of the motor vehicle referred to in subregulation (1) must -

- (a) within three months after the date on which he or she was notified of the theft, notify the appropriate registering authority of that theft on the approved form; and
- (b) submit the registration certificate of that motor vehicle and the notification referred to in paragraph (a), to the appropriate registering authority.

(5) If, on receipt of the notification referred to in subregulation (1)(c) or (4)(a) a registering authority is satisfied that such notification is in order, it must -

- (a) update the particulars pertaining to the motor vehicle concerned in the register of motor vehicles referred to in regulation 366(6)(a);

REGULATIONS
Road Traffic and Transport Act 22 of 1999
Road Traffic and Transport Regulations, 2001

- (b) in the case of the notification referred to in subregulation (4)(a), issue a deregistration certificate on the approved form, to the title-holder of that motor vehicle; and
- (c) issue an acknowledgement of receipt of the notification referred to in subregulation (1)(c) on the approved form.

(6) If a registering authority has acknowledged receipt of the notification referred to in subregulation (5)(c), the owner of the motor vehicle concerned is exempt from the licensing of that motor vehicle with effect from the first day of the month following the month in which the acknowledgement was issued, but any period during which the owner of that motor vehicle was unable to notify the appropriate registering authority due to circumstances beyond his or her control, must be disregarded.

(7) If a motor vehicle referred to in subregulation (1) is recovered, the owner of the motor vehicle must -

- (a) within 24 hours after the recovery, notify the Namibian Police thereof;
- (b) notify the title-holder and the appropriate registering authority forthwith of that recovery; and
- (c) apply for the licensing of that motor vehicle as referred to in regulation 31 and the application must be accompanied by a Police clearance of that motor vehicle.

(8) The Namibian Police and, if applicable, the registering authority must on receipt of the notification referred to in subregulation (7), update the register of vehicles accordingly.

Procedure if motor vehicle becomes permanently unfit for use as motor vehicle

90. (1) If a motor vehicle becomes permanently unfit for use as such, the owner of the motor vehicle must -

- (a) notify the title-holder forthwith thereof: and
- (b) within three months after the date on which that motor vehicle has become so unfit notify the appropriate registering authority, on the approved form that such motor vehicle is permanently unfit for use as a motor vehicle.

(2) The title-holder of a motor vehicle referred to in subregulation (1) must -

- (a) within three months after the date on which the motor vehicle has become permanently unfit, notify the appropriate registering authority on the approved form that such motor vehicle is permanently unfit; and
- (b) submit the registration certificate of that motor vehicle and the notification referred to in paragraph (a) to the appropriate registering authority.

(3) If, on receipt of a notification referred in subregulation (1)(b) or(2)(a), the registering authority is satisfied that the notification is in order, it must -

REGULATIONS
Road Traffic and Transport Act 22 of 1999
Road Traffic and Transport Regulations, 2001

- (a) update the particulars pertaining to the motor vehicle in the register of motor vehicles referred to in regulation 366(6)(a);
- (b) issue to the owner an acknowledgement of receipt of the notification referred to in subregulation (1)(b) on the approved form: and
- (c) in the case of the notification referred to in subregulation (2)(a), issue a deregistration certificate on the approved form to the title-holder of that motor vehicle.

(4) If a registering authority has in terms of subregulation (3)(b), acknowledged receipt of the notice referred to in subregulation (1)(b), the owner of the motor vehicle concerned is exempt from liability for the licensing of that motor vehicle, with effect from the first day of the month following the month in which the acknowledgement was issued, but any period during which the owner of that motor vehicle was unable to notify the appropriate registering authority due to circumstances beyond his or her control, must be disregarded.

Number to be affixed to motor vehicle

91. (1) Every motor vehicle must have -

- (a) a chassis number of not more than 17 alpha-numerical characters which must be cut, stamped, embossed on or permanently affixed to that motor vehicle: and
- (b) if it is a self-propelled vehicle, an engine number of not more than 20 alpha-numerical characters which must be cut, stamped, embossed on or permanently affixed to the engine of that motor vehicle.

(2) The chassis number of every motor vehicle registered for the first time on or after a date determined by the Minister in the *Gazette*, must comply with the standard specifications of the South African Bureau of Standards -

- (a) SABS 3779: 1983 “Road vehicles - Vehicle identification number (VIN) - Content and structure”;
- (b) SABS 4030: 1983 “Road vehicles - Vehicle identification number (VIN) - Location and attachment”;
- (c) SABS 3780: 1983 “Road vehicles - World Manufacturer identifier (WMI) code”, as published by South African Government Notice No. R.3160 of 20 November 1992,

(3) The title-holder of a motor vehicle -

- (a) which does not bear a chassis number;
- (b) which, if it is a self-propelled vehicle, does not bear an engine number;
- (c) which does not bear both the numbers referred to in paragraphs (a) and (b);
- (d) of which the number referred to in paragraph (a) or (b), appears on another motor vehicle; or

REGULATIONS
Road Traffic and Transport Act 22 of 1999
Road Traffic and Transport Regulations, 2001

- (e) of which the number referred to in paragraph (a) or (b) is altered, defaced or obliterated,

must tender the motor vehicle to the Namibian Police.

(4) The Namibian Police must, on payment of the appropriate fees contemplated in Schedule 1, issue a new number referred to in subregulation (3)(a) or (b) in respect of the motor vehicle referred to in that subregulation.

(5) The title-holder of a motor vehicle referred to in subregulation (3) must -

- (a) cause the number issued by the Namibian Police as referred to in subregulation (4) to be cut, stamped, embossed on or permanently affixed to that motor vehicle; and
- (b) obtain clearance from the Namibian Police in respect of the number referred to in paragraph (a).

(6) The number referred to in subregulation (4) is the chassis or engine number, as the case may be, of the motor vehicle concerned.

(7) The title-holder referred to in subregulation (5) must furnish the registering authority with the clearance referred to in that subregulation.

(8) The registering authority concerned must issue a new registration certificate reflecting the number issued in terms of subregulation (4), to the title-holder on payment of the fees prescribed in terms of section 18 of the Road Fund Administration Act, 1999.

Penalties for late registration or licensing

92. (1) If an application for the registration or licensing of a motor vehicle is not made within the period determined in this Chapter, the title-holder, owner or holder, as the case may be, must pay a penalty to the appropriate registering authority, calculated at 2.5 percent of the appropriate fees for every month or part of a month during which the fees remain unpaid and that the penalty may not exceed the total amount of the appropriate fees.

[subregulation (1) substituted by GN 81/2010]

(2) The payment by the title-holder or owner of a motor vehicle of the registration or licence fees, as well as the penalty referred to in subregulation (1), does not relieve that title-holder or owner from prosecution for his or her failure to register or licence the motor timeously nor does such prosecution of the title-holder, owner or holder for his or her failure to register or licence that motor vehicle, relieve him or her of the liability to pay the appropriate fees for registration or licensing, as well as the penalty referred to in subregulation (1).

(3) The title-holder or owner of a motor vehicle who submits an application on the approved form to the appropriate registering authority for the registration or licensing of a motor vehicle, together with the appropriate fees within the time allowed, but fails to furnish any relevant document or particulars which may be required by that registering authority, is, despite anything to the contrary contained in this regulation, not liable for any penalty if that registering authority is satisfied that the failure was due to circumstances beyond the control of title-holder, owner or holder.

REGULATIONS
Road Traffic and Transport Act 22 of 1999
Road Traffic and Transport Regulations, 2001

(4) If the Minister is satisfied that payment of registration or licence fees was delayed by a cause beyond the control or were not due to any fault on the part of the title-holder or owner of a motor vehicle, he or she may direct that a penalty paid in respect of the registration or licensing, or so much thereof as the circumstances appear to him or her to justify, be refunded to the title-holder, owner or holder.

(5) Penalties or fees payable in respect of the registration or licensing of a motor vehicle in terms of this Chapter which is not paid, is a debt due to the Road Fund Administration, established in terms of the Road Fund Administration Act, 1999, and must be reported by the registering authority concerned to the Road Fund Administration.

[The phrases “is not paid” and “is a debt” should be “are not paid” and “are debts” to accord with the subject “Penalties or fees”).]

(6) Notwithstanding anything to the contrary contained in these regulations, a motor vehicle of which the licence or roadworthy certificate has expired may, for the purpose contemplated in regulation 95, continue to operate on a public road for a grace period of 21 days as from the date of expiry on condition that the expired licence disc and roadworthy certificate are displayed in accordance with regulation 50.

[subregulation (6) inserted by GN 205/2004]

Vehicles exempt from payment of registration and licence fees

93. A motor vehicle -

- (a) of which the owner is a State in respect of which the Chief of the Namibia Defence Force certifies that it is a friendly State and that the motor vehicle is intended to be used exclusively for military purposes in Namibia; or
- (b) of which the owner is a foreign government, a diplomat representing a foreign country, an international or intergovernmental organisation or any person or class of persons as the Minister responsible for Foreign Affairs may determine, is exempt from the payment of registration and licence fees.

Arrear fees for licensing of motor vehicle or motor trade number

94. (1) If application is made for the licensing of a motor vehicle or a motor trade number in a month following the month in which liability for the licensing of the motor vehicle or motor trade number arose, arrear licence fees, calculated at one twelfth per month of the annual licence fees from the first day of the month in which liability for the licensing arose until the last day of the month preceding the month in which application is made, is payable.

(2) If a person who owes any penalties or fees in terms of this Chapter to any registering authority, applies for any transaction, the registering authority to whom that application is made may refuse to effect the transaction applied for, until the penalties and fees have been paid, and may apply any amount tendered in settlement of those penalties and fees due.

Period of grace

95. Where, in terms of this Chapter, provision is made for a period within which an application must be made, such period must be construed as a period of grace allowed to the

REGULATIONS
Road Traffic and Transport Act 22 of 1999
Road Traffic and Transport Regulations, 2001

applicant, during which he or she may make the application without being liable for a penalty referred to in regulation 92 or prosecution for not making the application timeously.

Procedure when cheque is dishonoured

96. (1) If any penalties or fees for a transaction in terms of this Chapter, are paid by cheque and the cheque is dishonoured on presentation, the registering authority concerned may notify the person concerned thereof in writing and, unless the drawer of that cheque honours the cheque within the period allowed by the registering authority, that person owes the registering authority the outstanding amount as well as a levy determined by the Minister.

(2) The registering authority must recover the amount and the levy referred to in subregulation (1) in a manner determined by the Minister.

Duty to furnish information

97. (1) A person requested by the Minister, an authorised officer or a registering authority to furnish information regarding a motor vehicle or a motor vehicle body which is or may have at any time been in his or her possession, must furnish that information.

(2) A person shall furnish such information as may be required by the Minister, an authorised officer or a registering authority regarding any matter in respect of which that person has responsibility in terms of the Act.

Duty of registering authority in respect of records

98. A registering authority must -

- (a) keep a file for every motor vehicle it registers or licenses;
- (b) record all the transactions it effects in the applicable register and keep record of those transactions.

[The word “a” appears to have been omitted before the phrase “record of those transactions”.]

Application for information certificate in respect of motor vehicle

99. (1) A person may apply to a registering authority, on the approved form for an information certificate in respect of a motor vehicle.

(2) The application referred to in subregulation (1) must be accompanied by -

- (a) the acceptable identification of the applicant;
- (b) where the applicant is a body of persons, the acceptable identification of the proxy and representative of that body of persons;
- (c) where the applicant is a body of persons, a letter of proxy indicating the proxy and representative’s right to represent that body of persons; and
- (d) the appropriate fee contemplated in Schedule 1.

Exporting of motor vehicle

REGULATIONS
Road Traffic and Transport Act 22 of 1999
Road Traffic and Transport Regulations, 2001

100. (1) If the owner of a motor vehicle, other than a manufacturer or a builder of a new motor vehicle, intends to export the motor vehicle, that owner must notify the appropriate registering authority thereof on the approved form.

(2) On receipt of a notification referred to in subregulation (1), the registering authority must -

- (a) update the particulars pertaining to the motor vehicle in the register of motor vehicles referred to in regulation 366(6)(a); and
- (b) acknowledge receipt of the notification on the approved form.

Manner in which mass measuring certificate to be obtained

101. (1) A mass measuring certificate on which the tare and particulars of the motor vehicle concerned are reflected, must be obtained by the applicant thereof at his or her own expense from a person in charge of an approved weighing device.

(2) The tare of a motor vehicle referred to in subregulation (1) must be determined in the presence of a person nominated by the Minister.

CHAPTER 4
FITNESS OF DRIVERS

PART 1
DRIVING TESTING CENTRES

Manner of application for registration as driving testing centre and identification of management representative

102. (1) After a date determined by the Minister by notice in the *Gazette*, every person or authority who the Minister intends to appoint in terms of section 27 of the Act must apply to him or her on the approved form for the registration of a driving testing centre, and a management representative must be identified in respect of the driving testing centre concerned.

[The word “who” should be “whom” to be grammatically correct.]

(2) An application referred to in subregulation (1) must be accompanied by acceptable identification of the applicant and of the signee of the application and the appropriate fee contemplated in Schedule 1.

Requirements for registration of driving testing centre

103. The requirements for registration as a driving testing centre must be in accordance with the requirements specified in a manual for the evaluation of driving testing centres approved by the Minister and which manual must be available for inspection during office hours at the offices of the Under Secretary of Transport, Ministry of Works, Transport and Communication, Windhoek.

Manner of registration of driving testing centre

REGULATIONS
Road Traffic and Transport Act 22 of 1999
Road Traffic and Transport Regulations, 2001

102 - **104.** (1) The Minister must, on receipt of an application made in terms of regulation

- (a) require the inspectorate of driving testing centres to -
 - (i) evaluate the driving testing centre concerned according to the requirements referred to in regulation 103; and
 - (ii) recommend the appropriate grading thereof in terms of regulation 106;
- (b) with due regard to the evaluation and recommendation of the inspectorate of driving testing centres, satisfy himself or herself that the driving testing centre concerned complies with the requirements contemplated in regulation 1 03; and
- (c) satisfy himself or herself that the registration of the driving testing centre concerned has not been suspended or cancelled for a reason that still applies.

- (2) (a) If the Minister is satisfied in terms of subregulation (1)(b), he or she must -
 - (i) register and grade that driving testing centre in terms of regulation 106;
 - (ii) record the particulars of that testing centre on the register of driving testing centres referred to in regulation 366(1)(a)(vi); and
 - (iii) issue to the applicant a certificate of registration on the approved form, which certificate must be displayed at a conspicuous place at the driving testing centre.
- (b) If the Minister is not satisfied in terms of subregulation (1)(b), he or she may refuse to register that driving testing centre and must notify the applicant accordingly.

(3) The management representative of a driving testing centre whose application for registration is refused and which appeals against that refusal in terms of section 29 of the Act must furnish the Minister and the inspectorate of driving testing centres with a copy of the appeal.

(4) Despite subregulations (1) to (3), a driving testing centre which does not comply with the requirements contemplated in regulation 103 and which is operating as a driving testing station on the date of commencement of these regulations, may be provisionally registered and graded on condition that the procedures followed to test an applicant for a driving licence and the design of the driving testing centre must as far as possible be in accordance with the specification referred to in that regulation.

(5) At a date to be determined by the Minister by notice in the *Gazette*, the provisional registration and grading lapse, whereupon the driving testing centre -

- (a) if it has fulfilled the requirements contemplated in regulation 103, must be registered and graded in accordance with this regulation; or
- (b) if it has not so fulfilled such requirements, the registration and grading thereof must be cancelled.

Change of registration particulars

REGULATIONS
Road Traffic and Transport Act 22 of 1999
Road Traffic and Transport Regulations, 2001

105. (1) The management representative identified in terms of regulation 102 must, within 21 days after the change of any particulars contemplated in regulation 102(2), notify the Minister of that change on the approved form and send a copy of that notification to the inspectorate of driving testing centres.

(2) The Minister must, on receipt of a notification referred to in subregulation (1), update the register of driving testing centres referred to in regulation 366(1)(a)(vi) accordingly.

Grades of driving testing centres

106. (1) The Minister must, with due regard to the evaluation and recommendation of the inspectorate of driving testing centres, grade a driving testing centre as grade A, B, C, D or E, as the case may be, if the driving testing centre complies with the appropriate grading requirements contemplated in regulation 103.

(2) A driving testing centre, which is graded in term or subregulation (1) -

- (a) as a grade A driving testing centre, is authorised to examine and test a person for a learner's or driving licence of any code;
- (b) as a grade B driving testing centre, is authorised to examine and test a person for a learner's licence of any code or driving licence of the code B, EB, C1, C, EC1 and EC;

[The word "code" should be "codes" to be grammatically correct; otherwise the word "and" in the closing phrase should be "or" as in paragraph (c) below.]

- (c) as a grade C driving testing centre, is authorised to examine and test a person for a learner's licence of any code or driving licence of the code A, A1 or B;
- (d) as a grade D driving testing centre, is authorised to examine and test a person for a learner's licence of any code or driving licence of the code B: or
- (e) as a grade E driving testing centre, is authorised to examine and test a person for any code of learner's licence.

Powers and duties of inspectorate of driving testing centres

107. (1) The inspectorate of driving testing centres -

- (a) must evaluate a driving testing centre in accordance with the requirements contemplated in regulation 103, and recommend to the Minister -
 - (i) the suitability of a driving testing centre to be registered as a driving testing centre; and
 - (ii) the grading of the driving testing centre;
- (b) must in respect of every registered driving testing centre conduct at least one inspection per year to monitor the standards maintained at that driving testing centre;
- (c) may advise any driving testing centre on the improvement and maintenance of testing facilities and procedures at that testing centre;

REGULATIONS
Road Traffic and Transport Act 22 of 1999
Road Traffic and Transport Regulations, 2001

- (d) must, when necessary, recommend to the Minister the suspension or cancellation of the registration of a driving examiner: and
 - (e) must, when necessary, recommend to the Minister the suspension or cancellation or the registration of a driving testing centre.
- (2) A person employed by, or who acts on behalf of the inspectorate of driving testing centres, may at any reasonable time, without prior notice -
- (a) enter the premises of any driving testing centre;
 - (b) inspect and impound any records of that driving testing centre;
 - (c) question any person with regard to any matter relating to the operation of that driving testing centre; and
 - (d) accompany a driving examiner in any motor vehicle when the examiner is examining or testing a person for a driving licence or be present while an applicant for a learner's licence is being examined,

to determine whether the driving testing centre complies with the requirements referred to in regulation 103.

Manner of suspension or cancellation of registration of driving testing centre

108. (1) If the inspectorate recommends to the Minister that the registration of a driving testing centre is suspended or cancelled, the Minister must, in considering that suspension or cancellation -

- (a) notify the management representative identified in terms of regulation 102, of the failure of the driving testing centre to comply with the requirements of regulation 103; and
- (b) demand from that management representative to indicate in writing -
 - (i) the reason for the failure; and
 - (ii) the details of the measures that have been taken to rectify and prevent that failure.

(2) If the Minister is not satisfied with the reason or measures referred to in subregulation (1)(b), he or she must inform the management representative and may suspend or cancel the registration of that driving testing centre.

(3) If the Minister suspends or cancels the registration of a driving testing centre, he or she must -

- (a) notify that driving testing centre of the suspension or cancellation and the reasons therefor and, in the case of suspension, the period thereof; and
- (b) cause a notice of the suspension or cancellation referred to in paragraph (a) to be displayed in a conspicuous place at that driving testing centre.

REGULATIONS
Road Traffic and Transport Act 22 of 1999
Road Traffic and Transport Regulations, 2001

(4) The management representative of a driving testing centre, the registration of which has been cancelled, must within 14 days after having been notified of the cancellation, submit to the Minister -

- (a) the certificate of registration referred to in regulation 104(2)(a)(iii) issued in respect of that driving testing centre;
- (b) any blank licences held but not issued by that driving testing centre; and
- (c) a reconciliation of forms held and issued, and blank forms.

(5) If the driving testing centre against which has been acted in terms of subregulation (2), appeals in terms of section 29 of the Act, the management representative of that driving testing centre must furnish the Minister and the inspectorate of driving testing centres with a copy of the appeal.

(6) The Minister may request the inspectorate of driving testing centres to investigate any allegation brought against a driving testing centre or a person in the employ of a driving testing centre.

Fee to defray expenditure incurred by inspectorate of driving testing centres

109. (1) The Minister may, in consultation with the Minister of Finance, determine a fee to be paid to the inspectorate of driving testing centres to defray expenditure incurred by that inspectorate in the exercise and performance of its powers and duties in terms of these regulations.

(2) The fee referred to in subregulation (1) may be recovered as a percentage of the appropriate fee contemplated in Schedule 1 for the examination for a driving licence.

(3) The Minister may, in consultation with the Minister of Finance, determine the manner in which, date on which and the institution to which the percentage of the fee contemplated in subregulation (2) must be paid.

(4) The inspectorate of driving testing centres must submit to the Minister not later than 1 July of each year, a statement of costs incurred and if applicable, of fees received by or on behalf of that inspectorate for the period of 1 April to 31 March of the preceding year.

[The word “preceding” is misspelt in the *Government Gazette*, as reproduced above.]

PART 2
LEARNERS’ AND DRIVING LICENCES

Categories of learners’ licences and driving licences, classes of motor vehicles and age restrictions relating to each category of licence

110. (1) The categories of learners’ licences and the classes of motor vehicles pertaining to those licences are as follows:

- (a) Code 1: Motorcycle;

[paragraph (a) substituted by GN 163/2002]

REGULATIONS
Road Traffic and Transport Act 22 of 1999
Road Traffic and Transport Regulations, 2001

- (b) Code 2: Motor vehicle, other than a motorcycle, the tare of which does not exceed 3 500 kilograms, a minibus, bus or goods vehicle the gross vehicle mass of which does not exceed 3 500 kilograms, an articulated motor vehicle or combination of motor vehicles and trailer of which the gross combination mass of the truck-tractor or drawing vehicle does not exceed 3 500 kilograms, or a tractor;

[Paragraph (b) is amended by GN 163/ 2002. The deletion of text as directed leaves an extra comma after the word "motorcycle".]

- (c) Code 3: Motor vehicle, other than a motorcycle, the tare of which exceeds 3 500 kilograms, a minibus, bus or goods vehicle the gross vehicle mass of which exceeds 3 500 kilograms, an articulated motor vehicle of which the gross combination mass of the truck-tractor exceeds 3 500 kilograms or a combination of motor vehicles of which the gross combination mass of the drawing vehicle exceeds 3 500 kilograms.

[paragraph (c) substituted by GN 163/2002]

- (2) The minimum age at which a person may obtain a learner's licence, is as follows:

- (a) Code 1, in respect of a class of motorcycle authorised by a code A1 driving licence: 16 years;
- (b) Code 1, in respect of a class of motorcycle authorised by a code A driving licence: 17 years;
- (c) Code 2: 17 years;
- (d) Code 3: 18 years.

- (3) The authority to drive a motor vehicle conferred by a learner's licence is subject to the following conditions:

- (a) The holder of a learner's licence must, except if the licence relates to a motor vehicle having no seating accommodation for a passenger or to a motorcycle, when driving that motor vehicle, be accompanied in or on that motor vehicle by, and be under the direct personal supervision of, a person seated next to him or her or immediately behind him or her, if that person cannot be seated next to him or her, and who is in possession of a licence, other than a learner's or similar licence, authorising him or her to drive that class of motor vehicle;
- (b) The holder of a learner's licence must, whenever he or she is driving a motor vehicle, excluding a motorcycle, ensure that a red sign in the form of the letter "L", of a size of at least 300mm by 200mm, is displayed in the rear window on the right-hand side of the motor vehicle that he or she is driving;
- (c) a learner's licence, in respect of a motorcycle without side-car, does not authorise the holder thereof to drive the motorcycle on a public road while carrying a passenger;
- (d) a learner's licence does not authorise the driving of a motor vehicle while conveying passengers for reward, other than a person accompanying the holder of a learner's licence in terms of paragraph (a);

REGULATIONS
Road Traffic and Transport Act 22 of 1999
Road Traffic and Transport Regulations, 2001

- (e) a learner’s licence with the code mentioned in the first column of Table 1 below, issued before the date determined by the Minister by notice in the *Gazette*, is regarded as a learner’s licence with the code indicated against it in the second column of the table:

TABLE 1

PREVIOUS CODE	NEW CODE
Code 01, 02, 03, 04, or a code 12 for the aforementioned codes. [Section 58(1)(a) to (d)]	Code 1
Code 05, 06, 07, 08 or 09 or a code 12 for the aforementioned codes. [Section 58(1)(e) to (h)]	Code 2
Code 10, or 11 or a code 12 for the aforementioned codes. [Section 589(1)(i) to (l)]	Code 3

[Table 1 substituted by GN 163/2002]

(4) The categories of driving licences are indicated by the codes mentioned in the first column of Table 1 or 2, each of which pertains to the classes of motor vehicles mentioned against it in the second column of the table, and authorises the holder of such code to drive the motor vehicle authorised by the codes mentioned against it in the said second column and third column of the table.

(5) For the purpose of Table 2, the words “motor vehicle” do not include a type of agricultural or industrial equipment or machinery not designed principally for the conveyance of persons or goods or a motorcycle:

TABLE 2

CODE	CLASS OF MOTOR VEHICLE	AUTHORISATION
(a) A1	A motor cycle with an engine cylinder capacity not exceeding 125 cubic centimetres, or propelled by electrical power, but excluding - (i) a pedestrian-controlled vehicle propelled by electrical power derived from storage batteries; or (ii) a vehicle with a tare not exceeding 230 kg specially designed and constructed, and not merely adapted, for use by a person suffering from a physical defect or disability or a person of old age and used solely by that person.	Code A1
(b) A	A motor cycle with an engine cylinder capacity exceeding 125 cubic centimetres.	Codes A and A1
(c) B	A motor vehicle, being - (i) a motor car, the tare of which does not exceed 3 500 kg; or	Code B, a tractor and a motor vehicle being mobile agricultural or industrial equipment

REGULATIONS
Road Traffic and Transport Act 22 of 1999
Road Traffic and Transport Regulations, 2001

	<p>(ii) a minibus, a bus or a goods vehicle, the gross vehicle mass of which does not exceed 3 500 kg;</p> <p>without a trailer, or with a trailer the gross vehicle mass of which does not exceed 750 kg, but excluding an articulated motor vehicle.</p>	<p>or machinery not designed principally for the conveyance of persons or goods, with or without a trailer</p>
(d) BE	<p>A motor vehicle, excluding a tractor, being -</p> <p>(i) an articulated motor vehicle, of which the gross combination mass of the truck-tractor does not exceed 3 500 kg;</p> <p>(ii) a combination of -</p> <p style="padding-left: 20px;">(aa) a motor car the tare of which does not exceed 3500 kg; or</p> <p style="padding-left: 20px;">(bb) a minibus, bus or goods vehicle, the gross vehicle mass of which does not exceed 3500 kg,</p> <p>with a trailer, the gross vehicle mass of which exceeds 750 kilograms.</p>	<p>Codes B and BE</p>
(e) C1	<p>A motor vehicle, being -</p> <p>(i) a motor car, the tare of which exceeds 3 500 kg but not 16 000 kg;</p> <p>(ii) a minibus, bus or a goods vehicle, the gross vehicle mass of which exceeds 3 500 kg but not 16 000 kg,</p> <p>without a trailer, or with a trailer the gross vehicle mass of which does not exceed 750 kg, but excluding an articulated motor vehicle.</p>	<p>Codes C1 and B</p>
(f) C	<p>A motor vehicle, being a bus or a goods vehicle, the gross vehicle mass of which exceeds 16 000 kg without a trailer, or with a trailer the gross vehicle mass of which does not exceed 750 kilograms, but excluding an articulated motor vehicle.</p>	<p>Codes B, C and C1</p>
(g) C1E	<p>A motor vehicle, excluding a tractor, being -</p> <p>(i) an articulated motor vehicle, of which the gross combination mass of the truck-tractor does not exceed 3 500 kg but not 16 000 kg;</p> <p>(ii) a combination of a motor vehicle and trailer, the gross vehicle mass of the trailer of which exceeds 750 kg, but the gross combination mass of the drawing vehicle of which does not exceed 16 000 kg.</p>	<p>Codes B, C1, BE and C1E and CE</p>

REGULATIONS
Road Traffic and Transport Act 22 of 1999
Road Traffic and Transport Regulations, 2001

(6) Subject to subregulation (2), the minimum age at which a person may obtain a driving licence is as follows:

- (a) Code A1: 16 years;
- (b) Code A, B, C1, C, BE, C1E and CE: 18 years.

[paragraph (b) amended by GN 163/2002]

(7) Until a date determined by the Minister by notice in the *Gazette*, a driving licence issued or deemed to have been issued in terms of the repealed Ordinance also authorises the driving of a motor vehicle for which the corresponding code of driving licence is required, as shown in Table 3.

(8) For the purposes of Table 1 and Table 3 “code 12 licence” means a driving licence issued in terms of the repealed Ordinance authorising the driving of a motor vehicle specially adapted, constructed or equipped for use by a physically disabled person.

(9) Where a driving licence issued or deemed to have been issued in terms of the repealed Ordinance (hereafter referred to as the “old licence”), is exchanged in terms of section 40(2) of the Act, the authority granted by the driving licence so exchanged is as prescribed for the relevant code of that licence in subregulation (4).

(10) Notwithstanding anything to the contrary in these regulations -

- (a) the holder of a code 05 or code 07 driving licence referred to in Table 3 must, on application in terms of regulation 124, be issued in terms of regulation 118 with a new code B driving licence which -
 - (i) in the case of an application which relates to a code 05 licence, contains an endorsement indicating that the holder of that licence is only authorised to drive a tractor of any mass, with or without a trailer of any mass; and
 - (ii) in the case of an application which relates to a code 07 licence, contain an endorsement indicating that the holder of that licence is only authorised to drive a motor vehicle which is a type of mobile agricultural or industrial equipment or machinery not designed principally for the conveyance of persons or goods, of any mass, with or without a trailer of any mass.
- (b) the authority granted by the new licence is as prescribed for the code of that licence in Table 2 in subregulation (5); but if the licence is a code C1E driving licence, the holder of it is authorised to drive the class of motor vehicle for which he or she had authority under the old licence.

[paragraph (e) amended by GN 163/2002]

(11) In the case where the old licence authorises the driving of a motor vehicle which is propelled by electrical power, the authority granted by the new licence is, subject to that licence being endorsed in terms of section 37(6)(a) of the Act, as prescribed for the relevant code of that licence in Table 2.

(12) If the holder of an old licence can only drive the vehicle concerned aided by spectacles, contact lenses or an artificial limb or other physical aid, the authority granted by the

REGULATIONS
Road Traffic and Transport Act 22 of 1999
Road Traffic and Transport Regulations, 2001

new licence is, subject to that licence being endorsed in terms of section 37(6)(b) of the Act, as prescribed for the relevant code of that licence in Table 2.

(13) If an application for the exchange of a licence in terms of section 40(2) of the Act relates to a code C1E, CE or C licence and the applicant -

- (a) is disqualified by reason of defective vision as contemplated in regulation 112 from holding those licences; or
- (b) cannot comply with regulation 128, but qualifies to hold a code BE licence,

that application is deemed to be an application for a code BE licence and the applicant must be issued with a code EB licence.

[subregulation 13 substituted by GN 163/2002]

TABLE 3

CODE	LICENCE ISSUED ON OR AFTER 01/07/1972 IN TERMS OF SECTION 58 OF THE REPEALED ORDINANCE	LICENCE ISSUED UP TO 31/06/1972
(a) A1	Motor cycle without sidecar with an engine cylinder capacity not exceeding 50 cubic centimetres or propelled by electrical power and generally known as “code 1”, and a code 12 licence pertaining to such cycle. [Sec 58(1)(a)]	Motor cycle (not exceeding 125 cm ²)
(b) A	<ul style="list-style-type: none"> (i) Motor cycle with sidecar and generally known as “code 3” and a motor tricycle generally known as “code 4”, and a code 12 licence pertaining to such cycle. [Sec 58(1)(b)]; (ii) A licence of any code authorising the driving of a motor quadrucycle; and (iii) Motor cycle without sidecar with an engine cylinder capacity exceeding 50 cubic centimetres or propelled by electrical power and generally known as “code 2”, and a code 12 licence pertaining to such cycle. 	Motor cycle (exceeding 125 cm ²) motor cycle with side-car, motor tricycle [A comma is missing after the bracketed phrase.]
(c) B	Tractor, motor vehicle propelled by electrical power, agricultural or industrial equipment or machinery, generally known as “codes 5, 6 and 7”, and a code 12 licence pertaining to such vehicles. [Sec 58(1)(e) and (f) and (g)]	Tractor, motor vehicle propelled by electrical power, motor vehicle propelled by steam power
(d) BE	<ul style="list-style-type: none"> (i) Motor vehicle of which the tare does not exceed 3 500 kg; or (ii) bus or goods vehicle of which the gross vehicle mass does not exceed 3 500 kg, both generally known as “code 8”, and a code 12 licence pertaining to such vehicles [Sec 58(1)(h)].	Light motor vehicle with a tare or gross vehicle mass not exceeding 700 lb

REGULATIONS
Road Traffic and Transport Act 22 of 1999
Road Traffic and Transport Regulations, 2001

(e)	C1 -	-
(f)	-	-
(g)	C1E (i) Motor vehicle of which the tare exceeds 3 500 kg but does not exceed 9 000 kg; (ii) bus or goods vehicle of which the gross vehicle mass exceeds 3 500 kg but does not 9 000 kg, both generally known as “code 9” [Sec 58(1)(i)]; and (iii) motor vehicle of which the tare exceeds 9 000 kg but does not exceed 16 000 kg; or (iv) bus or goods vehicle of which the gross vehicle mass exceeds 9 000 kg but does not exceed 16 000 kg, both generally known as “code 10” and a code 12 licence pertaining to such vehicles [Sec 58(1)(j)].	-
(h)	EC (i) Motor vehicle the tare of which exceeds 16 000 kg; or (ii) bus or goods vehicle, the gross vehicle mass of which exceeds 16 000 kg, generally known as “code 11” and a code 12 licence pertaining to such vehicles [Sec 58(1)(k)].	Heavy motor vehicle with tare or gross vehicle mass exceeding 7 700 lb

[Table 3 substituted by GN 163/2002]

Period of validity of learner’s licence, driving licence and professional authorisation

111. (1) Subject to section 34 of the Act, the period of validity of a learner’s licence issued in terms of section 36 of the Act is 18 months.

(2) Subject to section 34 of the Act, the period of validity of a driving licence issued in terms of section 37 of the Act is five years.

(3) The period of validity of a professional authorisation endorsed on a licence in terms of regulation 127 is two years.

[regulation 111 substituted by GN 163/2002]

Defective vision disqualifying person from obtaining or holding licence to drive motor vehicle

112. (1) A person is disqualified from obtaining or holding a learner’s or driving licence unless -

REGULATIONS
Road Traffic and Transport Act 22 of 1999
Road Traffic and Transport Regulations, 2001

- (a) in the case of an application for a licence of the codes A1, A, B, and BE, the person has -
- (i) a minimum visual acuity, with or without refractive correction, of 6/12 (20/40) for each eye or, if the visual acuity of one eye is less than 6/12 (20/40) or if one eye of the person concerned is blind, a minimum visual acuity for the other eye of 6/9 (20/30); and
 - (ii) a minimum visual field of 70 degrees temporal, with or without refractive correction, in respect of each eye, or where the minimum visual field in respect of one eye is less than 70 degrees temporal, or where one eye is blind, a minimum total horizontal visual field of at least 115 degrees with or without refractive correction; or

[paragraph (a) amended by GN 163/2002]

- (b) in the case of an application for a licence of the codes C, C1, C1E or CE the person has -
- (i) a minimum visual acuity, with or without refractive correction, of 6/9 (20/33) for each eye; and
 - (ii) a minimum visual field of 70 degrees temporal in respect of each eye, with or without refractive correction.

[paragraph (b) amended by GN 163/2002]

(2) Subject to subregulation (3), an applicant's visual acuity and visual field must be tested for the purposes of subregulation (1) -

- (a) by a driving test centre; and
- (b) by means of an approved instrument.

[subregulation (2) substituted by GN 163/2002]

- (3) (a) If, upon a test in accordance with subregulation (2), it is found that an applicant's visual acuity or visual field does not meet any of the minimum requirements stipulated in subregulation (1), the applicant may, at his or her own expense, cause a further test to be carried out by a person of his or her choice who is registered and practising as an optometrist or an ophthalmologist under the laws of Namibia.
- (b) The result of a test carried out in terms of paragraph (a) must be recorded by the optometrist or ophthalmologist concerned on an approved form.
- (c) If the result of the further test as recorded in terms of paragraph (b) shows that the applicant is not disqualified as contemplated in subregulation (1), the result of that further test must be accepted by the driving testing centre for the purposes of that subregulation.

[subregulation (3) substituted by GN 163/2002]

REGULATIONS
Road Traffic and Transport Act 22 of 1999
Road Traffic and Transport Regulations, 2001

(4) A test carried out in respect of an applicant in accordance with subregulation (2) or (3) ceases to be of effect upon expiry of a period of 6 months after the date on which that test was effected if the applicant has failed to complete the theoretical test referred to in regulation 114 successfully before the expiry of that period, in which event the applicant must undergo the test in accordance with subregulation (2) or (3) afresh.

[subregulation 4 inserted by GN 163/2002]

Manner of application for learner's licence

113. (1) An application in terms of section 36(1) of the Act must be made to a driving testing centre on the approved form, and must -

- (a) contain the results of the applicant's visual acuity and visual field tests carried out in accordance with regulation 112;
- (b) be accompanied by -
 - (i) acceptable identification of the applicant;
 - (ii) the appropriate fee shown in Schedule 1 in respect of an application for a learner's licence;
 - (iii) if the applicant is older than 65 years, a medical certificate on the approved form, signed by a medical practitioner, attesting that the applicant is not disqualified in terms of section 34(1)(f) of the Act from obtaining a learner's licence and driving licence.

[subregulation (1) substituted by GN 163/2002]

- (2) If the applicant -
 - (a) is on the day determined by the driving testing centre, for any reason whatsoever, not examined and tested; and
 - (b) is unable to satisfy the driving testing centre concerned that the reason for his or her not having been examined and tested is due to circumstances beyond his or her control, he or she must again pay the appropriate fee contemplated in Schedule 1 if the driving testing centre determines another day and time on which he or she must present himself or herself to be examined and tested.

Procedure of test for a learner's licence

114. (1) An applicant for a learner's licence must be examined and tested by a driving examiner in accordance with the theoretical testing procedures prescribed in an approved manual.

(2) The manual referred to in subregulation (1) must be available for public inspection during normal office hours at the offices of the driving testing centre concerned.

[regulation 114 substituted by GN 163/2002]

Manner of issue of learner's licence and reinstatement of suspended learner's licence

REGULATIONS
Road Traffic and Transport Act 22 of 1999
Road Traffic and Transport Regulations, 2001

115. (1) If an applicant for a learner's licence satisfactorily completes the theoretical test referred to in regulation 114, the applicant must -

- (a) if no image capturing device is available at the driving testing centre concerned, submit two identical photographs of himself or herself which comply with the requirements of subregulation (4); and
- (b) pay the appropriate fee prescribed in Schedule 1 for the issue of a learner's licence.

(2) If subregulation (1) is complied with, and if the driving examiner is satisfied with regard to the matters provided for in section 36(3) of the Act, the driving examiner or a person authorised thereto by him or her must -

- (a) complete the required documents for the issue of a learner's licence;
- (b) if applicable, ensure that the learner's licence is endorsed in accordance with section 36(3)(a) or (b) of the Act;
- (c) if an image capturing device is available at the driving testing centre concerned -
 - (i) capture a photographic image of the applicant on the forms approved for learner's licences and image confirmation;
 - (ii) issue a learner's licence on the approved form;
 - (iii) ensure that the applicant signs the learner's licence and the approved form for image confirmation; and
 - (iv) attach the approved form for image confirmation to the applicant's application form for filing;
- (d) if an image capturing device is not available at the driving testing centre concerned -
 - (i) issue a learner's licence on the approved form;
 - (ii) affix one of the photographs referred to in subregulation (1)(a) to the learner's licence and affix a lamination strip in such a manner as to cover the photograph and a portion of the personal particulars of the holder of the learner's licence; and
 - (iii) ensure that the applicant signs the learner's licence; and
 - (iv) attach the second photograph referred to in subregulation (1)(a) to the applicant's application form for filing.

(3) If a learner's licence expires without the holder having obtained a driving licence for the particular class of vehicle, such person must obtain a learner's licence afresh in accordance with the provisions of these regulations if he or she intends to apply for a driving licence for that class of vehicle.

(4) The photographic image of an applicant referred to in subregulation (2)(c)(i) and the photographs referred to in subregulation (1)(a) must -

REGULATIONS
Road Traffic and Transport Act 22 of 1999
Road Traffic and Transport Regulations, 2001

- (a) be of a size not smaller than 35mm x 40mm and not larger than 40mm by 55mm;
- (b) be a clear and true depiction of only the head and shoulders of the applicant; and
- (c) show the applicant's face in full face and, except with the permission of the Minister, show the applicant without headgear.

(5) Upon the cancellation or suspension of a learner's licence under section 42 of the Act, the Minister or the licence inspector authorised thereto by the Minister, must forthwith notify the authority where record of that licence is kept of the cancellation or suspension.

[The word "the" appears to have been omitted before the word "record".]

(6) If a suspended learner's licence is reinstated by the Minister under section 42(10) of the Act, the Minister must in writing give notice of that decision to -

- (a) the authority concerned;
- (b) the holder of the suspended licence; and
- (c) send the suspended learner's licence submitted by the holder in terms of section 42(9) to that authority.

(7) If, upon reinstatement of a suspended learner's licence notified in terms of subregulation (6), the period of validity of that licence has not yet expired -

- (a) the holder of that licence must submit to the authority concerned acceptable identification of himself or herself in order to obtain the return of the learner's licence; and
- (b) the authority concerned, upon receipt of acceptable identification of the holder of the learner's licence in terms of paragraph (a), must -
 - (i) return the learner's licence to that person;
 - (ii) obtain from him or her an acknowledgement of receipt of the learner's licence on the approved form; and
 - (iii) record the return of the learner's licence in the register of licences referred to in regulation 366(2)(a)(iii).

(8) If the period of validity of a suspended learner's licence expires during the period of suspension without the licence having being reinstated in terms of section 42(10) of the Act, the holder thereof must obtain a learner's licence afresh in accordance with these regulations if he or she intends to apply for a driving licence for that class of vehicle.

[The word "being" should be "been" to fit the sentence structure.]

[regulation 115 substituted by GN 163/2002]

Manner of application for driving licence and for renewal thereof

REGULATIONS
Road Traffic and Transport Act 22 of 1999
Road Traffic and Transport Regulations, 2001

116. (1) An application for a driving licence in terms of subsection (1) of section 37 of the Act, or the renewal of a driving licence in terms of subsection (7) of that section, must be made to a driving testing centre on the approved form and must be accompanied by -

- (a) acceptable identification of the applicant;
- (b) the appropriate fee prescribed in Schedule 1 for an application for a driving licence or the renewal of a driving licence, as the case may be; and
- (c) if the driving licence applied for or to be renewed must be endorsed in accordance with regulation 127, the documents, permit, if applicable, and fee referred to in regulation 128.

[subregulation (1) substituted by GN 163/2002]

- (2) If the applicant for a driving licence in terms of section 37(1) of the Act -
 - (a) is on the day determined in terms of section 37(3), for any reason whatsoever, not examined and tested; and
 - (b) is unable to satisfy the driving testing centre concerned that the reason for his or her not having been examined and tested is due to circumstances beyond his or her control, he or she must again pay the appropriate fee contemplated in Schedule 1 if the driving testing centre determines another day and time on which he or she must present himself or herself to be examined and tested.
- (3) An application for the renewal of a driving licence -
 - (a) must be made to the driving testing centre at least six weeks before the period of validity of the driving licence expires; and
 - (b) is not subject to the applicant being required to be examined and tested in accordance with regulation 117, except in the circumstances contemplated in subregulation (3) of that regulation.

[subregulation (3) inserted by GN 163/2002]

(4) If the holder of a driving licence fails to make application for the renewal of the licence timeously in accordance with paragraph (a) of subregulation (3), but makes such application before the date on which the licence expires and, because of such failure, cannot be issued with a renewed licence card before the expiry date, that person may not drive on a public road a motor vehicle of the class to which the driving licence relates until the renewed licence card is issued in terms of regulation 118, unless that person applies for and, upon payment of the appropriate fees prescribed in Schedule 1, is issued with a temporary licence authorising the driving of a motor vehicle of the particular class.

[subregulation (4) inserted by GN 163/2002]

(5) If the holder of a driving licence fails to make application for the renewal of the licence before the date upon which the licence expires that licence may, subject to subregulation (6), nevertheless be renewed upon application by the holder of the licence -

[The word "subregulation" is misspelt in the Government Gazette, as reproduced above.]

REGULATIONS
Road Traffic and Transport Act 22 of 1999
Road Traffic and Transport Regulations, 2001

- (a) if such application is made within the period of 12 months following the date of expiry of the licence, upon payment of the appropriate fee prescribed in Schedule 1; or
- (b) if such application is made after the expiry of the period of 12 months referred to in paragraph (a), upon -
 - (i) the driving testing centre concerned being satisfied by the holder of the driving licence in writing that good reasons exist for his or her failure to renew the licence before the date of its expiry and during the period referred to in paragraph (a); and
 - (ii) payment of the appropriate fee prescribed in Schedule 1.

**[subregulation (5) inserted by GN 163/2002
and substituted by GN 290/2008]**

(6) The period of grace, contemplated in terms of section 37(11), within which a person, whose licence has expired, may apply for the renewal thereof is a period of 5 years from the date of commencement of the Road Traffic and Transport Amendment Act, 2008 (Act No. 6 of 2008).

[subregulation (6) inserted by GN 290/2008]

Examination and testing for driving licence or renewal thereof

117. (1) An applicant for a driving licence must be examined and tested by a driving examiner in accordance with the practical testing procedures prescribed in an approved manual.

(2) The manual referred to in subregulation (1) must be available for public inspection during normal office hours at the offices of each driving testing centre.

(3) An applicant for the renewal of a driving licence may, for the purposes of determining whether or not the licence should be renewed, be required to subject himself or herself to examination and testing in accordance with subregulation (1) if a driving examiner, with reference to the applicant's record of offences, has reasonable grounds to believe that the applicant does not have the required skills to be holder of a driving licence.

[The word "the" appears to have been omitted before the word "holder".]

(4) If a person applies for a driving licence with a professional authorisation referred to in regulation 127 to drive an articulated vehicle or a combination of motor vehicles, the practical test referred to in subregulation (1), must be conducted while the semi-trailer or trailer is attached to the truck-tractor or the drawing vehicle.

[regulation 117 substituted by GN 163/2002]

Manner of issue of driving licence

118. (1) An applicant for the issue of a driving licence who satisfactorily completes the practical test referred to in regulation 117, and an applicant for the renewal of a driving licence must -

REGULATIONS
Road Traffic and Transport Act 22 of 1999
Road Traffic and Transport Regulations, 2001

- (a) pay the appropriate fee prescribed in Schedule 1, if that fee has not already been paid for the simultaneous issue of a driving licence of a different code;
- (b) if an image capturing device is not available at the driving testing centre concerned, submit two identical photographs complying with regulation 115(4);
- (c) submit every licence held by him or her or any other document determined by the Minister; and
- (d) submit the documents referred to in regulation 119(1)(a)(i), if the applicant requires that the driving licence card be received by another person on his or her behalf from the driving testing centre.”.

[There is a superfluous quotation mark and full stop at the end of subparagraph (d).]

(2) Upon compliance with subregulation (1), the driving examiner or a person authorised thereto by the driving examiner must -

- (a) complete the authorisation to issue the driving licence on the approved form and record the authorisation on the register of licences referred to in regulation 366(2)(a)(iii);
- (b) indicate in the authorisation referred to in paragraph (a) whether the driving licence card should reflect any of the endorsements contemplated in -
 - (i) section 37(6) of the Act; or
 - (ii) in regulation 127;
- (c) if an image capturing device is available at the driving testing centre concerned -
 - (i) take imprints of the fingers starting with the left four fingers followed by the four right fingers and then the two thumbs together, and if the applicant has any missing finger, deselect the missing finger on the automated fingerprint recognition system;

[subparagraph (i) substituted by GN 298/2021]

- (ii) capture on the image capturing system a photographic image of the applicant complying with regulation 115(4);
- (iii) capture the applicant’s signature on the image capturing system;
- (iv) capture the serial number generated by the image capturing system on the application form and update the register of licences referred to in regulation 366(2)(a)(iii) accordingly;
- (v) order the driving licence from the card production facility unless the applicant has applied for the simultaneous issue of a driving licence of a different code;
- (d) if an image capturing device is not available at the driving testing centre concerned -

REGULATIONS
Road Traffic and Transport Act 22 of 1999
Road Traffic and Transport Regulations, 2001

- (i) take an imprint of the left thumb and right thumb of the applicant, but if the applicant does not have a left or right thumb, an imprint of an available finger in order of the index finger, middle finger, ring finger and little finger of the left hand and the right hand, and if the applicant does not have any fingers indicate it on the application;
 - (ii) affix one of the photographs referred to in subregulation (1)(b) to the approved form and the other photograph to the duplicate thereof;
 - (iii) ensure that the applicant signs the approved form and the duplicate;
 - (iv) capture the serial number contained on the approved form on the application form and update the register of driving referred to in regulation 366(2)(a)(iii) accordingly;
 - (v) order the driving licence from the card production facility unless the applicant has applied for the simultaneous issue of a driving licence of a different code;
 - (vi) forward the approved form referred to in subparagraph (iii) to the card production facility and retain the duplicate of that form;
- (e) issue a temporary driving licence referred to in regulation 123 free of charge and, if applicable, endorse the temporary driving licence with a professional authorisation contemplated in regulation 127;
- (f) attach the documents referred to in subregulation (1)(d), if applicable, to the application form for filing; and
- (3) On receipt of the order for the driving licence card, the card production facility must -
- (a) produce the driving licence card on the approved form;
 - (b) ensure that the expiry date of the driving licence card is indicated on the card; and
 - (c) forward the driving licence card to the driving testing centre concerned.
- (4) On receipt of the driving licence card referred to in subregulation (3), the driving testing centre must -
- (a) record the receipt of the driving licence card in the register of licences referred to in regulation 366(2)(a)(iii);
 - (b) ensure that the applicant, or if he or she is unable to collect the driving licence card, the person designated by him or her, acknowledges receipt of the driving licence card on the approved form and ensure that the provisions of regulation 119 are complied with;
 - (c) in the case of a renewal of a driving licence, retain and destroy the old driving licence card; and

REGULATIONS
Road Traffic and Transport Act 22 of 1999
Road Traffic and Transport Regulations, 2001

- (d) record the issue of the driving licence card in the register of licences referred to in regulation 366(2)(a)(iii).

(5) Except if previously otherwise agreed with the applicant, the driving examiner must destroy an unclaimed driving licence card after expiry of a period of 210 days after the receipt of the driving licence card, and record the fact that it has been destroyed in the register of licences referred to in regulation 366(2)(a)(iii).

[regulation 118 substituted by GN 163/2002]

Authorisation to allow person to receive licence card on behalf of another person

119. (1) Notwithstanding regulation 118 -

- (a) if an applicant knows that he or she will be unable to receive the driving licence card in person at the driving licence testing centre -

(i) the application for a driving licence card must be accompanied by -

(aa) a certified copy of the identity document of the person who will receive the card on the applicant's behalf; and

(bb) an affidavit made by the applicant stating the reason why he or she will be unable to receive the card in person, and the name and identification number of the person who will receive the card on his or her behalf; and

(ii) the person whose name and identification number appears on the affidavit must receive the card on behalf of the applicant and must present his or her identity document upon such receipt; or

[The word "appears" should be "appear" to accord with the subject "name and identification number".]

- (b) if an applicant is unable to receive the card in person due to unforeseen circumstances, the person who receives the card on behalf of the applicant must submit -

(i) his or her identity document and a certified copy thereof;

(ii) a certified copy of the identity document of the applicant; and

(iii) an affidavit made by the applicant which contains an explanation of the unforeseen circumstances preventing him or her from receiving the card in person and the name and identification number of the person who will receive the card on his or her behalf.

(2) The driving testing centre must, on submission of the said documents issue the card to the said person.

Manner of application for the issue of duplicate learner's licence or driving licence

REGULATIONS
Road Traffic and Transport Act 22 of 1999
Road Traffic and Transport Regulations, 2001

120. (1) An application for the issue of a duplicate learners' licence must be made by the holder of the original learner's licence to the driving testing centre on an approved form, which must be accompanied by -

[The word "learners" should be "learner's" to be grammatically correct.]

- (a) the fee prescribed in Schedule 1;
- (b) acceptable identification of the applicant;
- (c) the original learner's licence, or if the original is lost, stolen or destroyed, an affidavit to that effect by the applicant; and
- (d) if, there is no capturing device available at the driving testing centre, two identical photographs of the applicant, which photographs comply with requirements of regulation 115(4).

[The word "the" appears to have been omitted before the word "requirements".]

(2) On receipt of an application referred to in subregulation (1), the driving testing centre must -

- (a) determine whether the applicant is a holder of a valid learner's licence;
- (b) ensure that the learner's licence referred to in paragraph (a) is not subject to suspension or cancellation; and
- (c) issue to the applicant a duplicate learner's licence in accordance with regulations 115, which applies with necessary changes to this regulation.

[The phrase "regulations 115" should be "regulation 115".]

(3) An application for the issue of a duplicate driving licence must be made by -

- (a) the holder of the original driving licence; or
- (b) by a person nominated by the holder of the original driving licence, if the holder is unable to apply as contemplated in paragraph (a),

to the driving testing centre on an approved form.

(4) The form referred to in subregulation (3) must -

- (a) in the case of subregulation (3)(a), be accompanied by -
 - (i) the fee prescribed in Schedule 1;
 - (ii) the acceptable identification of the applicant;
 - (iii) the original driving licence in the case where the original licence is defaced, or if the original licence is lost, stolen or destroyed, an affidavit to that effect by the applicant; and

REGULATIONS
Road Traffic and Transport Act 22 of 1999
Road Traffic and Transport Regulations, 2001

- (iv) if the applicant is unable to collect the duplicate driving licence card from the driving testing centre in person, an authorisation as contemplated in regulation 119;
- (b) in the case of subregulation (3)(b), in addition to the requirements listed in paragraph (a)(i), (iii) and (iv), be accompanied by -
 - (i) acceptable identification of the nominee;
 - (ii) a certified copy of the acceptable identification of the holder of the original driving licence; and
 - (iii) a letter of nomination signed by the holder of the original driving licence containing the date of nomination, the reasons for nomination the type of nomination, and if applicable the number of the acceptable identification of the person nominated.
- (5) On receipt of an application referred to in subregulation (3), the driving testing centre concerned must -
 - (a) determine whether the applicant or person on whose behalf the application is made is a holder of a valid driving licence;
 - (b) ensure that the driving licence is not subject to suspension or cancellation; and
 - (c) issue to the applicant or person as the case may be a duplicate driving licence in accordance with regulation 118 which applies with necessary changes to this regulation.

[regulation 120 substituted by GN 32/2005]

Conditions for acknowledgement and exchange of foreign driving licence and international driving permit

121. (1) Subject to subregulation (3), a licence referred to in section 41(1)(a) of the Act is, during the period of validity thereof in the country of issue, deemed to be a valid licence for the purpose of Chapter 4 of the Act -

- (a) if the licence was issued in English by the country of issue; or
- (b) in the case of a licence not issued in English by the country of issue, if a certificate of validity relating to that licence issued in English by a competent authority of that country, or a translation of that licence in English by a sworn translator, is attached thereto; and
- (c) if the licence contains or has attached thereto a photograph and the signature of the holder thereof.

[subregulation (1) substituted by GN 163/2002]

(2) Subject to subregulation (3), an international driving permit referred to in section 41(1)(b) of the Act is deemed to be a valid licence for the purpose of Chapter 4 of the Act for the period of validity thereof and subject to the conditions under which it was issued.

REGULATIONS
Road Traffic and Transport Act 22 of 1999
Road Traffic and Transport Regulations, 2001

(3) The period contemplated in section 41(2) of the Act for which a licence referred to in subregulation (1) must be deemed to be a licence for the purpose of Chapter 4 of the Act, is 12 months, calculated from -

- (a) the date of entry into Namibia if such a person is a Namibian citizen; or
- (b) the date of issue of permanent residence if such a person is a permanent resident.

[subregulation (3) substituted by GN 163/2002 and by GN 98/2016]

(4) A licence referred to in subregulation (1) or an international driving permit referred to in subregulation (2), may, at any time during the period of validity thereof in the country of issue, be replaced by a licence issued in terms of Chapter 4 of the Act.

[subregulation (4) substituted by GN 163/2002]

(5) An application for the replacement of a licence or permit in terms of section 41(3) of the Act must be made to a driving testing centre on the approved form and must be accompanied by the licence to be replaced.

[subregulation (5) substituted by GN 163/2002]

(6) On receipt of an application referred to in subregulation (5), the driving testing centre concerned must, subject to the Convention, issue a driving licence -

- (a) of a class or classes of motor vehicles referred to in regulation 110(4), which must be similar to the class or classes authorised by the licence to be replaced;
- (b) in the manner contemplated in regulation 118, if it is satisfied that -
 - (i) the applicant is the holder of the licence or permit to be replaced; and
 - (ii) the licence or permit is still valid in the country of issue.

[subregulation (6) substituted by GN 163/2002]

(7) If there is a dispute as to the class in respect of which a driving licence has been issued in terms of subregulation (5)(a), the Minister must determine the class of the licence.

(8) Notwithstanding the provisions of this regulation, the holder of a driving licence issued in a country determined by the Minister in the *Gazette*, must be tested in accordance with regulation 117 before a driving licence may be issued to him or her in terms of subregulation (6).

(9) A person exchanging a driving licence in terms of subregulation (8) must be a holder of -

- (a) a permanent residence permit;
- (b) a temporary residence permit; or
- (c) a work permit and must have stayed in Namibia for not less than 12 months.

REGULATIONS
Road Traffic and Transport Act 22 of 1999
Road Traffic and Transport Regulations, 2001

[subregulation (9) inserted by GN 156/2015 and substituted by GN 98/2016]

Authorisation that serves as licence in terms of section 31 of the Act

122. (1) A temporary licence, issued on the approved form by a driving examiner or a person authorised to issue such licence, is a temporary authorisation for the purpose of section 31 of the Act, for a period of eighteen months from the date of issue, or until the date on which the person to whom the authorisation has been issued, receives the original or duplicate licence.

[subregulation (1) substituted by GN 188/2006]

- (2) (a) Subject to paragraphs (b) and (c), a copy of an affidavit regarding the theft, loss, destruction or defacement of a licence made at a driving testing centre, registering authority or police station and which -
- (i) contains the official date stamp of the authority concerned;
 - (ii) contains the -
 - (aa) full names;
 - (bb) identity number or date of birth;
 - (cc) both the residential and postal addresses; and (dd) code of licence with all endorsements and restrictions applicable thereto, of the deponent; and
 - (iii) describes the circumstances under which the licence was stolen, lost, destroyed or defaced, is an authorisation in terms of section 31 of the Act.
- (b) If the affidavit referred to in paragraph (a) is made at a police station, such affidavit must also contain the case record number.
- (c) The affidavit referred to in paragraph (a) serves as an authorisation referred to in section 31 of the Act for a period of three days after the date of issue thereof.
- (d) The driving testing centre, registering authority or police station at which an affidavit is made must retain the original of that affidavit for record purposes.

Application and issue of temporary driving licence

123. (1) A person whose driving licence has been lost, stolen, destroyed or defaced may on the approved form apply to a driving testing centre apply for a temporary driving licence and the application must be accompanied by -

[The word “apply” after the phrase “apply to a driving testing centre” is superfluous.]

- (a) acceptable identification of the applicant;
- (b) if an image capturing device is not available at the driving testing centre concerned, two identical photographs of the description in regulation 115(4); and

REGULATIONS
Road Traffic and Transport Act 22 of 1999
Road Traffic and Transport Regulations, 2001

- (c) the appropriate fee prescribed in Schedule (1).

[Paragraph (c) should refer to "Schedule 1".]

[subregulation (1) substituted by GN 163/2002]

(2) On receipt of the request referred to in subregulation (1) a driving examiner or a person authorised thereto must -

- (a) determine whether the person is the holder of a valid licence;
- (b) if an image capturing device is available at the driving testing centre concerned -
 - (i) capture an imprint of the left thumb and right thumb of the applicant, but if the applicant does not have a left or right thumb, an imprint of an available finger in order of the index finger, middle finger, ring finger and little finger of the left hand and the right hand, and if the applicant does not have any fingers indicate it on the application;
 - (ii) capture on the image capturing system a photographic image of the applicant complying with regulation 115(4);
 - (iii) capture the signature of the applicant on the image capturing system;
- (c) if an image capturing device is not available at the driving testing centre concerned, affix one of the photographs referred to in subregulation (1)(b) to the approved form and the other photograph to the duplicate thereof;
- (d) complete the temporary driving licence on the approved form and indicate the relevant code of driving licence and professional authorisation referred to in regulation 127, if applicable, next to the identity number of such person;
- (e) ensure that the person signs the form;
- (f) affix one lamination strip to the original form and another to the copy thereof to cover the photograph, portion of the personal particulars, expiry date, code of licence and professional authorisation of that person; and
- (f) issue the original temporary driving licence to that person.

[Subregulation (2) is substituted by GN 163/2002. There are two paragraphs labelled (f); the second paragraph (f) should be paragraph (g). The placement of the second paragraph (f) in the *Government Gazette* is obviously in error and has been corrected here.]

Replacement of driving licence under section 40 of the Act

124. (1) The holder of a driving licence issued under the repealed Ordinance or of a licence issued before the commencement of this Part, who wishes to replace that licence must apply for the replacement from the date determined by the Minister under section 40(2) of the Act..

[The second full stop at the end of subregulation (1) is superfluous.]

REGULATIONS
Road Traffic and Transport Act 22 of 1999
Road Traffic and Transport Regulations, 2001

(2) An application in terms of subregulation (1) must be made on the approved form, and must -

- (a) contain the result of the visual acuity and visual field test carried out in accordance with regulation 112; and
- (b) be accompanied by -
 - (i) acceptable identification of the holder;
 - (ii) the appropriate fee prescribed in Schedule 1;
 - (iii) the photographs, documents and licence referred to in regulation 118(1);
 - (iv) any public driving permit held by him or her, if applicable;
 - (v) in the instance of a person having been admitted to a medical facility, a medical certificate issued by the medical facility upon which is indicated the date of admittance into and date of discharge from such medical facility;
 - (vi) in the instance of a person having been detained in any state institution in terms of an order issued or sentence imposed by a court of law, an official document upon which is indicated the date from which such person was detained and the date upon which such person was released from such state institution;
 - (vii) in the instance of a person having been posted by the Government on a foreign mission or assignment, an official document issued by the Government indicating the date of departure from Namibia for purposes of commencement of such post and the date of return to Namibia from such post;
 - (viii) in the instance of a person having been employed outside the borders of Namibia, a document issued by the employer of such person indicating the date upon which such employment commenced and the date upon which such employment ended; and
 - (ix) in the instance of a person having been enrolled as a full-time student at a foreign academic institution, an official document from such academic institution indicating the date upon which such full-time studies commenced and the date upon which such full-time studies were completed or terminated.

[subregulation (2) substituted by GN 290/2008]

(3) An applicant for the replacement of a driving licence is not required to subject himself or herself to examination and testing as contemplated in regulation 117.

(4) If the driving examiner or any other person authorised thereto by the driving examiner is satisfied that the application complies with subregulation (2), the driving examiner or person must, in addition to the provisions of regulation 118(2) -

- (a) if the licence to be replaced was issued in terms of the repealed Ordinance or the repealed Schedule 4 to these Regulations -

REGULATIONS
Road Traffic and Transport Act 22 of 1999
Road Traffic and Transport Regulations, 2001

- (i) cancel the licence by endorsing it with the word “cancelled”;
 - (ii) retain the licence and attach it to the form referred to in subregulation (2); and
 - (iii) if the applicant requires to retain proof of the licence, stamp and sign a copy thereof and hand it to the applicant;
- (b) if the licence to be replaced is contained in a South African identity document issued before 21 March 1990 -
- (i) make a copy of that licence and the identification of the applicant and attach it to the application referred to in subregulation (2);
 - (ii) endorse that licence, or any other appropriate place in the identity document, with the words “REPLACED”; and
 - (iii) return the identity document to the applicant;
- (c) if a public driving permit is submitted by the applicant in terms of subregulation (2)(b)(iv) -
- (i) retain the public driving permit and attach it to the application referred to in subregulation (2); and
 - (ii) if the applicant requires to retain proof of the public driving permit, stamp and sign a copy thereof and hand it to the applicant;
- (5) Regulation 118 applies, with the changes required by the context, to the replacement of a driving licence or permit contemplated in this regulation.

[regulation 124 substituted by GN 163/2002]

Change of particulars

125. If the postal or street address, the name or identification number or any other information pertaining to the holder of a licence issued in terms of Chapter 4 of the Act changes, that holder must notify the authority where the licence was issued of such a change on the approved form.

Manner of application for and issue of driving licence free of endorsements

126. An application for and issue of a driving licence free of endorsements in terms of section 43 or 44 of the Act must be made in the manner prescribed in regulation 116, in so far as it relates to the driving licence concerned.

Professional authorisation in terms of section 33(c) of the Act pertaining to certain categories of driving licences

- 127.** (1) Subject to subregulation (3), the holder of a driving licence -
- (a) of the code C1, C, C1E and CE;

REGULATIONS
Road Traffic and Transport Act 22 of 1999
Road Traffic and Transport Regulations, 2001

- (b) of any code, if the vehicle to which it relates is used to convey passengers for reward;
- (c) of any code, if the vehicle to which it relates is used to convey dangerous goods and if the Standard Specifications referred to in regulation 304 apply to that vehicle; or
- (d) of any code, if the vehicle to which it relates is a breakdown vehicle,

may not drive the vehicle authorised by the driving licence code or a breakdown vehicle, convey dangerous goods or convey passengers for reward, unless that driving licence is endorsed with a professional authorisation of the category referred to in subregulation (2).

[subregulation (1) substituted by GN 163/2002]

- (2) The categories of professional authorisation are:
 - (a) “P”, which authorises the conveyance of passengers only;
 - (b) “G”, which authorises the conveyance of goods only; and
 - (c) “D”, which authorises the conveyance of dangerous goods and goods; and

[subregulation (2) substituted by GN 163/2002]

(3) Subregulations (1) and (2) do not apply to a driving licence if the vehicle to which it relates to is -

[The word “to” after the phrase “to which it relates” is superfluous.]

- (a) a hearse;
- (b) a motor vehicle not designed or adapted for the conveyance of goods or persons, excluding a breakdown vehicle.

(4) Subregulations (1) and (2) do not apply to a person holding a learner’s licence in relation to any of the codes referred to in those subregulations, but the driving licence of the person accompanying the person holding a learner’s licence as contemplated in regulation 110(3)(a), must be endorsed in terms of this regulation.

(5) Subject to regulation 129, a driving licence referred to in subregulation (1) may be endorsed in any combination of the categories referred to in subregulation (2).

[subregulation (5) inserted by GN 163/2002]

Application for and renewal of professional authorisation

128. (1) An applicant for, or the holder of, a driving licence of a code referred to in regulation 127(1), may apply for a professional authorisation -

- (a) concurrently with the application for the driving licence concerned as contemplated in regulation 116; or

REGULATIONS
Road Traffic and Transport Act 22 of 1999
Road Traffic and Transport Regulations, 2001

(b) whenever it becomes necessary for the holder of a driving licence to drive a vehicle of the class referred to in regulation 127(1) on a public road.

(2) An application for a professional authorisation in terms of subregulation (1), must, in addition to the requirements of regulation 116, be accompanied by -

- (a) a medical certificate issued on the approved form not more than two months before the date on which application is made;
- (b) if applicable, a public driving permit held by the applicant;
- (c) an indication of the category or categories of professional authorisation that is being applied for;
- (d) the appropriate fee prescribed in Schedule 1;
- (e) proof of completion of an approved training course if application is made for a category “D” professional authorisation;
- (f) a statement obtained from the Namibian Police declaring whether the record of offences of the applicant shows that the applicant has been convicted of any offence referred to in regulation 129(1)(e);
- (g) in the case of an application contemplated in subregulation (1)(b), the driving licence card of the applicant for the professional authorisation.

(3) The driving examiner or a person authorised thereto by him or her must -

- (a) if the applicant for a driving licence applies for both a driving licence and professional authorisation simultaneously, comply with the provisions of regulation 118;
- (b) if the holder of a driving licence applies for a professional authorisation as contemplated in subregulation (1)(b), verify that the driving licence held by the applicant is not suspended or cancelled and the provisions of regulation 118 apply with the changes required by the context;
- (c) record the application for the professional authorisation on the register of licences referred to in regulation 366(2)(a)(iii).

(4) The provisions of regulation 118 and 119 regarding the issuing of a driving licence apply with the necessary amendments to an application for the endorsement of a professional authorisation on a driving licence.

[The singular word “regulation” should be the plural word “regulations”.]

(5) Notwithstanding the period of validity of a driving licence that contains an endorsement of a professional authorisation contemplated in this regulation, the holder of that driving licence must, at least six weeks before the period of validity of the professional authorisation expires, apply to a driving testing centre for the renewal of that professional authorisation in accordance with this regulation.

REGULATIONS
Road Traffic and Transport Act 22 of 1999
Road Traffic and Transport Regulations, 2001

(6) despite anything to the contrary in this regulation, where the holder of a professional authorisation applies for renewal thereof before the date of its expiry, such authorisation remains valid provided that the holder thereof can show proof that he or she applied for a police statement referred to in subregulation (2)(f) (known as the *police conduct certificate*) at least 14 days prior to the expiry of such authorisation.

[Subregulation (6) is substituted by GN 2/2008.
The word “despite” at the beginning of this subregulation should be capitalised.]

(7) Despite subregulation (2)(e), an applicant for a professional authorisation may, until a date determined by the Minister by notice in the *Gazette*, submit a letter by his or her employer certifying that he or she has been sufficiently trained in the conveyance of dangerous goods by the employer.

(8) If the driver concerned leaves the employ of the employer referred to in subregulation (7) and is employed by another employer to convey dangerous goods of a nature that he or she has not been trained to convey, his or her professional authorisation expires on the last day of his or her employment at the employer referred to in subregulation (7).

[regulation 128 substituted by GN 163/2002]

Conditions governing professional authorisation in relation to driving licence

129. (1) A driving testing centre may not endorse a driving licence in terms of section 33(c) of the Act unless -

- (a) the applicant has qualified to be issued with a driving licence of a class referred to in regulation 127;
- (b) the applicant, in the case of an application for an endorsement for the conveyance of passengers for reward must be at least 25 years of age;

[paragraph (b) substituted by GN 157/2015]

- (c) the applicant, in the case of an application for an endorsement for the conveyance of dangerous goods -
 - (i) is 25 years of age;
 - (ii) has completed a training course approved by the Minister;
- (d) the applicant is declared medically fit by a medical practitioner defined in section 1 of the Medical and Dental Act, 2004 (Act No. 10 of 2004) for the purposes of obtaining a professional authorisation in terms of these Regulations.

[Paragraph (d) is amended by GN 163/2002 and substituted by GN 157/2015. The Medical and Dental Act 10 of 2004 has been replaced by the Health Professions Act 16 of 2024.]

- (e) if the applicant has, within a period of five years prior to the date of the application, been convicted of -
 - (i) driving a motor vehicle while under the influence of intoxicating liquor or a drug having a narcotic effect;

REGULATIONS
Road Traffic and Transport Act 22 of 1999
Road Traffic and Transport Regulations, 2001

- (ii) driving a motor vehicle while the concentration of alcohol in his or her blood or breath exceeded a statutory limitation;
 - (iii) reckless or negligent driving; or
 - (iv) in the case of an application for an endorsement authorising the conveyance of passengers, an offence of which violence was an element;
- (f) the applicant is not a person who would be disqualified in terms of section 34 of the Act or regulation 112;
- (g) the applicant complies with any other condition the Minister may require.

(2) A person is not entitled to an endorsement in terms of regulation 127, during a period in which an endorsement is suspended or cancelled.

Endorsement of licence to reflect professional authorisation

130. A driving testing centre must, upon being satisfied that an applicant referred to in regulation 128 is entitled to have his or her driving licence endorsed in terms of section 33(c) of the Act and on payment of the appropriate fee contemplated in Schedule 1, in addition to the issuing procedure followed in terms of regulation 118, endorse the applicant's driving licence in accordance with regulation 127, and update the register of driving licences referred to in regulation 366(2)(a)(iii) accordingly.

Appeal

131. (1) A person who is aggrieved at the refusal by a driving testing centre to endorse his or her driving licence in accordance with regulation 27, may within 21 days of that refusal lodge a written notice of appeal with the Commission and must simultaneously submit a copy of the appeal to the driving testing centre concerned and the Minister.

(2) The driving testing centre concerned must forthwith, after receipt of the copy of the notice referred to in subregulation (1), furnish the Commission with reasons for the decision to which that notice refers.

(3) For the purpose of deciding an appeal in terms of subregulation (1), the Commission may require either party to the appeal to furnish such information or evidence, as it considers necessary.

(4) The secretary of the Commission must notify the parties concerned of the result of the appeal and if the appeal is allowed, the driving testing centre must give effect to the decision of the Commission.

Suspension or cancellation of professional authorisation

132. (1) A licence inspector or traffic officer who becomes aware of circumstances in relation to a person whose driving licence is endorsed with a professional authorisation in terms of regulation 127, which would have disqualified that person from obtaining that endorsement, must -

- (a) impound the driving licence to which the endorsement relates in terms of section 13(1)(h) or 14(1)(j) of the Act, as the case may be;

REGULATIONS
Road Traffic and Transport Act 22 of 1999
Road Traffic and Transport Regulations, 2001

- (b) issue a receipt for the impounded driving licence in terms of section 13(2) or 14(2)(a) of the Act, as the case may be;
- (c) notify the Minister in writing of the impoundment and the reasons therefor, and the driving licence impounded must accompany the notification;

[Subregulation (1) is substituted by GN 163/2002. There should be a full stop rather than a semicolon at the end of paragraph (c).]

(1A) On receipt of the notification referred to in subregulation (1)(c), the Minister must in writing request the holder of the impounded licence to submit to the Minister in writing, within 14 days from date of receipt of the request, any reasons why, in the opinion of the holder of the driving licence, the professional authorisation on the driving licence should not be suspended or cancelled.

[Subregulation (1A) is inserted by GN 163/2002. The word “the” appears to have been omitted before the phrase “date of receipt”.]

(1B) Upon consideration of any representations submitted pursuant to subregulation (1A), the Minister may on the facts before him or her -

- (a) cancel the endorsement for the professional authorisation;
- (b) suspend the professional authorisation for the period and on the conditions that the Minister considers necessary; or
- (c) return the impounded driving licence to the holder thereof.

[subregulation (1B) inserted by GN 163/2002]

(2) If the Minister cancels an endorsement or suspends a professional authorisation under subregulation (1), the Minister must give notice thereof to -

- (a) the holder of the driving licence; and
- (b) the driving testing centre where record of that driving licence is kept.

[Subregulation (2) is substituted by GN 163/2002. The word “the” appears to have been omitted before the word “record”.]

(3) On receipt of a notification in terms of subregulation (2), the driving testing centre must -

- (a) record the cancellation or suspension, as the case may be, in the register of licences referred to in regulation 366(2)(a)(iii);
- (b) issue to the person concerned a driving licence of a code authorised by the Minister.

[subregulation (3) substituted by GN 163/2002]

REGULATIONS
Road Traffic and Transport Act 22 of 1999
Road Traffic and Transport Regulations, 2001

(4) On expiry of the suspension referred to in subregulation (1), the holder of the suspended driving licence referred to in that subregulation may apply for a new driving licence, with or without an endorsement for a professional authorisation to a driving testing centre.

[subregulation (4) substituted by GN 163/2002]

(5) Where circumstances arise in relation to the holder of an endorsed licence or similar document issued outside Namibia, which, in the opinion of the Minister would have justified a driving testing centre in refusing to endorse such licence or similar document, or where the holder of such licence has been convicted of a second or subsequent offence which relates to the driving of a motor vehicle or a failure to stop after or report an accident, the Minister may inform such person that such endorsement or similar document is no longer of force and effect within Namibia and from the date such person is so informed such licence ceases to be of force within Namibia.

Prohibition in relation to professional authorisation

133. A person who -

- (a) is the operator, owner of or is in charge or control of a motor vehicle referred to in regulation 127, may not employ or permit any other person to drive that motor vehicle on a public road unless the driving licence of such other person is endorsed in accordance with regulation 127;
- (b) is the holder of a licence endorsed in accordance with regulation 127, may not allow any other person to use that licence.

Circumstances under which motor vehicle presumed to be motor vehicle conveying persons for reward

134. If, in any prosecution under the Act it is *prima facie* proved that a person has conveyed passengers for reward in a motor vehicle of which the gross vehicle mass does not exceed 3 500 kilograms, it is presumed, in absence of evidence to the contrary, that he or she conveyed the passengers for reward.

Voidness of professional authorisation

135. An endorsement with a professional authorisation on a driving licence made contrary to these regulations is void and the holder of a driving licence so endorsed must, on demand of the driving testing centre which made the endorsement, or a traffic officer, immediately deliver that driving licence to the driving testing centre or traffic officer.

Procedure for reinstatement of licence

135A. (1) Upon the cancellation or suspension of a driving licence in terms of section 42 of the Act, the Minister or the licence inspector authorised thereto by the Minister, must forthwith notify the authority where record of that licence is kept of the cancellation or suspension.

[The word “the” appears to have been omitted before the word “record”.]

(2) The authority concerned must record cancellation or suspension notified in terms of subregulation (1) in the register of licences referred to in regulation 366(2)(a)(iii).

REGULATIONS
Road Traffic and Transport Act 22 of 1999
Road Traffic and Transport Regulations, 2001

(3) If a suspended driving licence is reinstated by the Minister under section 42(10) of the Act, the Minister must -

- (a) give notice of that decision in writing to -
 - (i) the authority concerned;
 - (ii) the holder of the suspended licence; and
- (b) send the suspended driving licence submitted by the holder in terms of section 42(9) to that authority.

(4) If, upon reinstatement of a suspended driving licence referred to in subregulation (3), the period of validity of that licence has not yet expired -

- (a) the holder of that licence must submit to the authority concerned acceptable identification of himself or herself in order to obtain the return of the driving licence; and
- (b) the authority concerned, upon receipt of acceptable identification of the holder of the driving licence in terms of paragraph (a), must -
 - (i) return the driving licence to that person;
 - (ii) obtain from him or her an acknowledgement of receipt of the driving licence on the approved form; and
 - (iii) record the return of the driving licence in the register of licences referred to in regulation 366(2)(a)(iii).

(5) If upon reinstatement of a suspended driving licence the period of validity of the licence has expired, the holder thereof must renew that driving licence in accordance with the provisions of these regulations.

[regulation 135A inserted by GN 163/ 2002]

Manner of application to cancel or amend endorsement on licence

136. An application to cancel or amend an endorsement on a licence in terms of section 44(1) of the Act must be made to the Minister on the approved form and must be accompanied by two photographs of the applicant of the description referred to in regulation 115(4) and acceptable identification.

[regulation 136 amended by GN 163/2002]

Manner of application for licence free of endorsements by Court

137. An application in terms of section 43 of the Act must be made in accordance with regulation 116, in so far as it relates to that licence.

[regulation 137 amended by GN 163/2002]

REGULATIONS
Road Traffic and Transport Act 22 of 1999
Road Traffic and Transport Regulations, 2001

Competence and grading qualifications for instructors

138. (1) A person who desires to obtain an instructor's certificate contemplated in section 48 of the Act, must after a date determined by the Minister by notice in the *Gazette* obtain a diploma from an approved training centre.

(2) A person referred to in subregulation (1), must, on application for an instructor's certificate -

- (a) complete a theoretical test approved by the Minister;
- (b) complete the practical road test in accordance with the manual approved by the Minister, for the class of motor vehicle the person wishes to instruct; and
- (c) pay the appropriate fee contemplated in Schedule 1.

(3) The documents referred to in subregulation (2) must be available for inspection during office hours at the offices of the Under Secretary of Transport, Ministry of Works, Transport and Communication, Windhoek.

(4) The Minister may request any driving testing centre to conduct the test referred to in subregulation (2).

Manner of application for instructor's certificate

139. (1) An application in terms of section 48(1) of the Act must be made to the Minister on the approved form, and must be accompanied by -

- (a) certified copies of the diploma relating to the applicant's competence and qualifications as an instructor;
- (b) a record of offences identified in regulation 129(1)(e), of the applicant obtained from the Namibian Police;
- (c) a medical certificate on the approved form, the examination for which must have been conducted not more than two months prior to the date of application;
- (d) the appropriate fee contemplated in Schedule 1; and
- (e) such other information as may be required by the Minister.

(2) For the purposes of providing a record of offences referred to in subregulation (1)(b), any member of the Namibian Police may take fingerprints and palm prints of the applicant.

Manner of issue of instructor's certificate

140. (1) The Minister must, on receipt of an application in terms of regulation 139 -

- (a) satisfy himself or herself that the offence record of the applicant is satisfactory as contemplated in regulation 129(1)(e);

REGULATIONS
Road Traffic and Transport Act 22 of 1999
Road Traffic and Transport Regulations, 2001

- (b) ascertain that an instructor's certificate issued to the applicant has not been suspended for a reason that still applies;
- (c) satisfy himself or herself that the applicant -
 - (i) is the holder of a valid driving licence of the class of vehicle to which his or her application relates; and
 - (ii) complies with such further requirements as the Minister may determine.

(2) If the Minister is satisfied as to the suitability of the applicant in terms of subregulation (1) and regulation 139, he or she must issue to the applicant an instructor's certificate on the approved form on payment of the appropriate fee contemplated in Schedule 1 and subject to the conditions determined by the Minister.

(3) The holder of an instructor's certificate must, upon the permanent change of any of the particulars submitted in terms of regulation 139 notify the Minister of that change on the approved form.

(4) If the Minister is not satisfied as to the suitability of the applicant in terms of subregulation (1), he or she must notify that applicant accordingly.

Expiry and suspension or cancellation of instructor's certificate

141. (1) An instructor's certificate is valid for a period of two years from the date of issue, but the Minister may at any time cancel or suspend that instructor's certificate if -

- (a) the Minister is of the opinion that it is in the public interest that the instructor's certificate be cancelled or suspended, whether by reason of any criminal contraventions committed by such instructor or otherwise; or
- (b) there has been failure to comply with any of the conditions to which the instructor's certificate is subject,

and in such an event the Minister shall notify that person accordingly.

(2) The holder of an instructor's certificate which has been cancelled or suspended in terms of subregulation (1), must immediately surrender that certificate to the Minister.

(3) On the expiry of any period of suspension referred to in subregulation (1), the Minister must restore to the person entitled thereto the instructor's certificate surrendered in terms of subregulation (2) if the validity thereof has not expired.

(4) Where the holder of an instructor's certificate applies, before the expiry thereof, for a new instructor's certificate, the first-mentioned certificate, remains in force notwithstanding the expiry until that holder is notified of the result of his or her application for a new instructor's certificate by the Minister.

[The comma after the phrase "the first-mentioned certificate" is superfluous.]

Instructor's certificate to be carried on person of instructor

REGULATIONS
Road Traffic and Transport Act 22 of 1999
Road Traffic and Transport Regulations, 2001

142. An instructor's certificate issued in terms of regulation 140, must at all times be carried on the person of the instructor to whom it was issued while he or she is instructing, teaching or supervising another person.

Appeal

143. (1) If a person whose application for an instructor's certificate has been refused or whose instructor's certificate has been suspended or cancelled is aggrieved, he or she may, within 30 days from the date of that refusal, suspension or cancellation, appeal to the Commission against that refusal, suspension or cancellation.

(2) The applicant must serve a copy of the appeal on the Minister.

(3) The Commission may, after considering the appeal, make a decision it considers fit under the circumstances.

CHAPTER 5
FITNESS OF VEHICLES

PART 1
VEHICLE TESTING STATIONS

Manner of application for registration as vehicle testing station

144. (1) After a date determined by the Minister by notice in the *Gazette*, every person or authority who the Minister intends to appoint in terms of section 54 of the Act must apply to him or her on the approved form for the registration of a vehicle testing station, and a management representative must be identified in respect of the vehicle testing station concerned.

(2) An application referred to in subregulation (1) must be accompanied by -

- (a) acceptable identification of the applicant and of the signee of the application; and
- (b) the appropriate fee contemplated in Schedule 1.

Requirements for registration of vehicle testing station

145. The requirements for registration of a vehicle testing station are -

- (a) the level of technical competence required by the code of practice SABS 0216:1987 "Vehicle test station evaluation" published by the South African Government Notice No. 1652 of 19 August 1988; and
- (b) the manner of examination and testing of a motor vehicle at a testing station as required in the code of practice SABS 047:1995 "Testing of motor vehicles for roadworthiness" published by the South African Government Notice No. 298 of 22 February 1991.

Manner of registration of vehicle testing station

146. (1) The Minister must, on receipt of an application in terms of regulation 144 -

REGULATIONS
Road Traffic and Transport Act 22 of 1999
Road Traffic and Transport Regulations, 2001

- (a) require the inspectorate of vehicle testing stations to -
 - (i) evaluate the vehicle testing station concerned according to Code of Practice SABS 0216:1987 “Vehicle test station evaluation” as published by the South African Government Notice No. 1652 of 19 August 1988; and
 - (ii) recommend the appropriate grading therefor in terms of regulation 148;
 - (b) with due regard to the evaluation and recommendation of the inspectorate of vehicle testing stations, satisfy himself or herself that the vehicle testing station concerned complies with the requirements contemplated in regulation 145; and
 - (c) satisfy himself or herself that the registration of the vehicle testing station has not been suspended or cancelled for a reason that still applies.
- (2) (a) If the Minister is satisfied in terms of subregulation (1)(b) and (c), he or she must -
- (i) subject to the conditions he or she considers necessary, register and grade the vehicle testing station in terms of regulation 148;
 - (ii) record the particulars of the vehicle testing station on the register of vehicle testing stations referred to in regulation 366(1)(a)(viii);
 - (iii) issue to the applicant a certificate of registration on the approved form; and
 - (iv) provide upon payment of the cost of each form, as many roadworthy certificate forms and roadworthy discs as requested by the vehicle testing station concerned.
- (b) If the Minister is not satisfied in terms of subregulation (1)(b) and (c), he or she may refuse to register that vehicle testing station and must notify the applicant accordingly.
- (c) If the Minister registers and grades a vehicle testing station in terms of regulations 148, he or she must -
- (i) record the particulars of the vehicle testing station on the register of vehicle testing stations referred to in regulation 366(1)(a)(viii); and
 - (ii) issue to the applicant, on payment of the appropriate fee contemplate in Schedule I, a certificate of registration on the approved form.

[The word “contemplate” should be “contemplated” to fit the sentence structure.]

(3) A certificate of registration issued in terms of subregulation (2)(a)(iii) or (2)(c)(ii) must be displayed in a conspicuous place where members of the public who make use of the vehicle testing station can see that certificate.

Change of registration particulars

147. (1) The management representative identified in terms of regulation 144 must, upon the change of any of the particulars submitted in terms of that regulation, notify the

REGULATIONS
Road Traffic and Transport Act 22 of 1999
Road Traffic and Transport Regulations, 2001

Minister and the inspectorate of vehicle testing stations of the change on the approved form, within 14 days after that change.

(2) The Minister must, upon receipt of a notification referred to in subregulation (1), update the register of vehicle testing stations referred to in regulation 366(1)(a)(viii) accordingly.

Manner of grading of testing station

148. (1) The Minister must, with due regard to the evaluation and recommendation of the inspectorate of vehicle testing stations, grade a vehicle testing station as -

- (a) grade A, which authorises the vehicle testing station to test a motor vehicle of any class for roadworthiness; or
- (b) grade B, which authorises the vehicle testing station to test a motor vehicle with a gross vehicle mass (or gross combination mass in the case of an articulated motor vehicle) which does not exceed 3 500 kilograms.

(2) Despite subregulation (1), a vehicle testing station may be restricted to examine and test only -

- (a) vehicles owned and operated by certain persons;
- (b) vehicles of certain makes;
- (c) vehicles of certain models;
- (d) vehicles of certain classes;
- (e) vehicles with certain dimensions; or
- (f) such vehicles as may be determined by the Minister.

Terms and conditions of provisional registration and grading of vehicle testing station

149. (1) A vehicle testing station which does not comply with the requirements contemplated in regulation 145 and which is operating as a vehicle testing station on the date of commencement of these regulations, may be provisionally registered and graded on condition that the procedures followed and the equipment utilised for the testing of a motor vehicle for roadworthiness must as far as possible be in accordance with the specification referred to in that regulation.

(2) At a date to be determined by the Minister by notice in the *Gazette*, the provisional registration and grading lapse, whereupon the vehicle testing station -

- (a) if it has fulfilled the requirements contemplated in regulation 145, must be registered and graded in accordance with regulations 146 and 14; or
- (b) if it has not so fulfilled such requirements, the registration and grading thereof must be cancelled.

Manner of suspension or cancellation of registration of vehicle testing station

REGULATIONS
Road Traffic and Transport Act 22 of 1999
Road Traffic and Transport Regulations, 2001

150. (1) The Minister must, on being notified that a registered vehicle testing station or a provisionally registered vehicle testing station does not comply with regulation 145, or on a recommendation as contemplated in regulation 146(1)(a)(ii), immediately request the inspectorate of vehicle testing stations to investigate that vehicle testing station.

(2) The Minister must, in considering the suspension or cancellation of the registration of a vehicle testing station -

- (a) notify the management representative identified in terms of regulation 144, of the failure of the vehicle testing station to comply with the requirements of regulation 145: and
- (b) demand from that management representative to indicate in writing within 14 days from the date of the notification referred to in paragraph (a) -
 - (i) the reason for the failure; and
 - (ii) the details of the measures that have been taken to rectify and prevent the failure.

(3) If the Minister is not satisfied with the reason or measures referred to in subregulation (2)(b), he or she must inform the management representative and may suspend or cancel the registration of that vehicle testing station.

(4) If the Minister suspends or cancels the registration of a vehicle testing station, he or she must -

- (a) notify that vehicle testing station of the suspension or cancellation and the reasons therefor and, in the case of suspension, the period thereof; and
- (b) give notice in the *Gazette* of the suspension or cancellation referred to in paragraph (a)

(5) The management representative of a vehicle testing station, the registration of which has been cancelled, must within 14 days after having been notified of the cancellation, submit to the Minister -

- (a) the certificate of registration referred to in regulation 146(2)(n)(iii) issued in respect of the vehicle testing Station;
- (b) any certificates held but not issued by that vehicle testing station: and
- (c) a reconciliation of forms held and issued, and blank forms.

Powers and duties of inspectorate of vehicle testing stations

151. (1) The inspectorate of vehicle testing stations -

- (a) must evaluate a vehicle testing station in terms of regulation 145 as required in code of practice SABS 0216 "Vehicle test station evaluation" as published in the South African *Government Gazette* No. 1052 of 19 August 1988 and must recommend to the Minister -

REGULATIONS
Road Traffic and Transport Act 22 of 1999
Road Traffic and Transport Regulations, 2001

- (i) the suitability of the vehicle testing station for registration: and
- (ii) the grading of the vehicle testing station;
- (b) must in respect of a registered or provisionally registered vehicle testing station conduct at least one inspection per year to monitor the standards maintained at that vehicle testing station;
- (c) may advise a vehicle testing station on the improvement and maintenance of testing facilities and procedures:
- (d) must when a vehicle testing station does not comply with the requirements contemplated in regulation 145, recommend to the Minister the suspension or cancellation of the registration of that vehicle testing station; and
- (e) may investigate the activities of a registered or provisionally registered vehicle testing station.

(2) A person who acts on behalf of the inspectorate of vehicle testing stations, may at any reasonable time, having regard to the code or practice SABS 0216 "Vehicle test station evaluation" as published in the South African *Government Gazette* No. 1652 of 19 August 1988 -

- (a) inspect, examine or test any motor vehicle; and
- (b) without prior notice -
 - (i) enter the premises of any vehicle testing station;
 - (ii) inspect and impound any records of that vehicle testing station; and
 - (iii) question any person with regard to any matter relating to the operation of that vehicle testing station.

Fee to defray expenditure incurred by inspectorate of vehicle testing stations

152. (1) The Minister may, in consultation with the Minister of Finance, determine a fee to be paid to the inspectorate of vehicle testing stations to defray expenditure incurred by that inspectorate in the exercise of its powers and duties in terms of these regulations.

(2) The fee referred to in subregulation (1) may be recovered as a percentage of the appropriate fee contemplated in Schedule 1 for the testing of motor vehicles.

(3) The Minister may, in consultation with the Minister of Finance, determine the manner in which, date on which and the institution to which the percentage of the fee contemplated in subregulation (2) must be paid.

(4) The inspectorate of vehicle testing stations must submit to the Minister not later than 1 March of each year a statement of costs incurred and if applicable, of fees received by or on behalf of that inspectorate for the period of 1 January to 31 December of the preceding year.

PART 2
ROADWORTHY CERTIFICATES

REGULATIONS
Road Traffic and Transport Act 22 of 1999
Road Traffic and Transport Regulations, 2001

Roadworthy certificate required in certain circumstances

153. (1) Subject to subregulations (2) and (3), a registering authority may not issue a licence disc in respect of a -

- (a) used motor vehicle of which the owner has changed;
- (b) motor vehicle in respect of which a notice to discontinue operation was issued in terms of regulation 163;
- (c) motor vehicle built up from parts by a builder who is not required to register as such under these regulations;
- (d) motor vehicle referred to in regulation 44(1), which was reconstructed or altered;
- (e) motor vehicle imported into Namibia by an importer who is not required to register as such under these regulations;
- (f) motor vehicle manufactured, built, modified or imported by a manufacturer, builder or importer which is not registered in terms of regulation 81 or which is registered under the condition referred to in regulation 75(b)(ii);
- (g) goods vehicle with a gross vehicle mass which exceeds 3500 kilograms;
- (h) breakdown vehicle;
- (i) bus;
- (j) minibus -
 - (i) with a gross vehicle mass which exceeds 3500 kilograms; or
 - (ii) which is designed or adapted for the conveyance of 12 or more persons, including the driver;
- (k) motor vehicle used for the conveyance of persons for reward;
- (l) motor vehicle referred to in regulation 16(2)(f) in respect of which the certificate issued by the manufacturer referred to in that regulation does not contain the model number referred to in that regulation;
- (m) motor vehicle which has been found to be unroadworthy in terms of regulation 164(1)(a); or
- (n) motor vehicle regarded as unroadworthy in terms of regulation 164(2)(a) due to no reaction within 35 days after issue of a notice referred to in that regulation,

unless that motor vehicle is certified to be roadworthy as contemplated in regulation 156(2), within a period of six months prior to that motor vehicle being licenced.

[subregulation (1) substituted by GN 205/2004 and amended by GN 172/2007]

REGULATIONS
Road Traffic and Transport Act 22 of 1999
Road Traffic and Transport Regulations, 2001

(2) Subregulation (1) does not apply in respect of a motor vehicle referred to in paragraph (a) or (g) if that motor vehicle is a -

- (a) motor vehicle which was stolen and of which an insurance company has, after the recovery thereof, become the owner in terms of an insurance policy;
- (b) motor vehicle referred to in regulation 14(c) which was repossessed;
- (c) motor vehicle referred to in regulation 28(1), which is exempt from the payment of motor vehicle licence fees; or
- (d) a trailer, drawn by a tractor.

(3) Subregulation (1)(a) does not apply in respect of -

- (a) a motor vehicle acquired from a deceased spouse;
- (b) a motor vehicle of which the owner changes due to -
 - (i) the reconstruction of a company;
 - (ii) the amalgamation of companies;
 - (iii) the takeover of a company;
 - (iv) a scheme of arrangement in terms of section 311 to 313 of the Companies Act, 1973 (Act No. 61 of 1973);

**[The singular word "section" should be the plural word "sections".
 The Companies Act 61 of 1973 has been replaced by the Companies Act 28 of 2004.]**

- (v) the reconstruction of a close corporation, if, in the circumstances referred to in subparagraph (i), (ii) (iii) or (v), a board resolution or member resolution of the company who is the registered owner of that motor vehicle, as the case may be, sanctioning the reconstruction, amalgamation or takeover, or in the circumstances referred to in subparagraph (iv), the court order sanctioning the scheme of arrangement, is submitted to the registering authority concerned;
- (c) a motor vehicle other than a motor vehicle referred to in paragraphs (g), (h), (i), (j) and (k) of subregulation (1) of which the ownership of that motor vehicle has changed within six months after the date of liability for the first licensing of the motor vehicle; or

[paragraph (c) substituted by GN 205/2004]

- (d) a motor vehicle for which the branch of a business or body of persons is deemed to be the title-holder or owner in terms of regulation 14(a), where another branch of that business or body of persons becomes the owner or title-holder.

(4) Subregulation (1) does not apply to -

- (a) a motor vehicle referred to in paragraphs (c) or (d) of subregulation (2);

REGULATIONS
Road Traffic and Transport Act 22 of 1999
Road Traffic and Transport Regulations, 2001

- (b) a motor vehicle which is operated under the authority of a motor trade number or special permit;
- (c) a hearse; or
- (d) a motor vehicle owned by the Namibian Police or by the Namibian Defence Force and which motor vehicle is designed for combat support and which, by virtue of that design, does not comply with Parts 3, 4, and 5 of Chapter 5.

[subregulation (4) inserted by GN 205/2004]

Manner of application for roadworthy certificate

154. (1) An application for a roadworthy certificate must be made on the approved form at an appropriately graded vehicle testing station and must be accompanied by the appropriate fee contemplated in Schedule 1.

(2) On receipt of an application referred to in subregulation (1), the vehicle testing station concerned must determine the date, time and place for the examination and testing of the motor vehicle concerned.

Examination and testing of motor vehicle for roadworthiness

155. (1) An appropriately graded vehicle examiner must examine and test the motor vehicle referred to in regulation 154 as prescribed in code of practice SABS 047: 1995 "Testing of motor vehicles for roadworthiness", as published by the South African Government Notice No. R. 298 of 22 February 1991.

- (2) (a) A motor vehicle presented for an examination and test must be clean and all parts to be examined must be free from excessive grease, oil and dirt.
- (b) If a motor vehicle used to convey dangerous goods as contemplated in Part 4 of Chapter 6, is presented for an examination and test, the containment system of that motor vehicle must be purged so that the motor vehicle can be safely examined, tested and re-filled with another substance.
- (c) From 1 January 2002, a motor vehicle equipped with full air braking systems must be presented for an examination and test with test connections designed in accordance with standard specification SABS 1207:1985 "Motor Vehicle Safety Standard Specification for Braking" as published by Government Notice No. R.6 of 3 January 1986, fitted to the front circuit and before and after any load sensing valve, and such test connections must be in good working order.

Manner of certification of roadworthiness

156. (1)

[subregulation (1) deleted by GN 205/2004]

(2) If the vehicle examiner is satisfied that the motor vehicle is roadworthy and that the chassis number or engine number of the motor vehicle has not been tampered with, obliterated,

REGULATIONS
Road Traffic and Transport Act 22 of 1999
Road Traffic and Transport Regulations, 2001

mutilated or altered, the vehicle testing station must, on payment of the appropriate fee contemplated in Schedule 1, certify that the motor vehicle is roadworthy by -

- (a) in the case of a motor vehicle registered in Namibia, updating the particulars pertaining to that motor vehicle in the register of motor vehicles; or
 - (b) issuing the applicant with a roadworthy certificate on the approved form, in the case where the vehicle testing station concerned is unable to act in terms of paragraph (a), and if the motor vehicle is registered in Namibia, advise the applicant that the motor vehicle must be licensed.
- (3) (a) If the chassis number or engine number of the motor vehicle referred to in subregulation (2) has, in the opinion of the vehicle examiner, been tampered with, obliterated, mutilated or altered, the applicant referred to in subregulation (1) must submit a Police clearance in respect of that vehicle.
- (b) On submission of the Police clearance, the vehicle testing station must, if satisfied that the motor vehicle is roadworthy, certify the motor vehicle as roadworthy as contemplated in subregulation (2).

(4) If after the examination and testing of a motor vehicle the vehicle examiner is of the opinion that the motor vehicle is not roadworthy that examiner must provide the applicant with reasons for his or her opinion and may allow the applicant to remedy any defect in that motor vehicle within a period determined by him or her, but not exceeding 14 days after the date of the examination and testing, and if the examiner is thereafter so satisfied he or she must certify the motor vehicle as roadworthy as contemplated in subregulation (2).

[subregulation (4) substituted by GN 205/2004]

(5) Despite subregulation (2), a vehicle examiner authorised thereto in writing by the vehicle testing station concerned may, at any time before the motor vehicle, which is being or has been examined and tested for roadworthiness, is returned to the applicant, examine or re-examine that motor vehicle, and for that purpose -

- (a) he or she is deemed to be the vehicle examiner referred to in that subregulation; and
- (b) any prior action taken by a vehicle examiner in respect of that motor vehicle is deemed to be of effect.

(6) A person may not wilfully or negligently certify that a motor vehicle is roadworthy if that motor vehicle is not roadworthy.

(7) If a person wilfully or negligently certifies that a motor vehicle is roadworthy when that motor vehicle is not roadworthy, that certification is void.

(8) A person may not remove, replace or alter the components of a motor vehicle so that the roadworthiness of that motor vehicle is affected if that motor vehicle was certified to be roadworthy, except in the normal course of maintenance or use thereof.

Issue of roadworthy certificate

REGULATIONS
Road Traffic and Transport Act 22 of 1999
Road Traffic and Transport Regulations, 2001

157. On receipt of an application for the licensing of a motor vehicle referred to in regulation 153(1) the registering authority must, if satisfied that a licence disc may be issued in respect of the motor vehicle concerned, issue a licence disc and roadworthy certificate on the approved form referred to in regulation 32(2)(e) in respect of that motor vehicle.

[regulation 157 substituted by GN 205/2004]

Document deemed to be a roadworthy certificate

158. Subject to section 58(4) of the Act, in the case of a motor vehicle which is not registered in Namibia, a roadworthy certificate issued in terms of regulation 156(2)(b) or in terms of similar legislation in the country where that motor vehicle is registered is deemed to be a roadworthy certificate for a period of 12 months from the date of issue thereof.

[regulation 158 substituted by GN 205/2004]

Voidness of roadworthy certificate

159. (1) Any roadworthy certificate issued contrary to this Chapter is void.

(2) Subject to subregulation (3) a roadworthy certificate issued in respect of a motor vehicle becomes void where the motor vehicle is altered in such a manner that -

- (a) the roadworthy certificate no longer correctly describes the motor vehicle; or
- (b) the alteration affects the terms and conditions of the roadworthy certificate.

(3) Subregulation (2) does not apply in respect of a motor vehicle of which only the engine is replaced or the colour is changed, on condition that the owner of the motor vehicle notifies the appropriate registering authority of that change on the approved form, and the notification must be accompanied by a Police clearance.

(4) Where a vehicle examiner or traffic officer notifies the owner of a motor vehicle that that motor vehicle's roadworthy certificate is void the owner of that motor vehicle must, as soon as is reasonably possible, return the licence disc of that motor vehicle or if the licence disc and the roadworthy certificate of that motor vehicle are contained in separate documents the owner of that motor vehicle must return both that licence disc and that roadworthy certificate to the registering authority concerned.

[subregulation (4) substituted by GN 205/2004]

(5) On receipt of a notice referred to in subregulation (3), the registering authority must -

- (a) update the particulars pertaining to the motor vehicle concerned in the register of motor vehicles referred to in regulation 366(6)(a); and
- (b) issue a confirmation of such update on the approved form.

(6) For the purposes of this regulation, "colour" means the main colour of the body of a motor vehicle, viewed from the outside and as recorded in the register of motor vehicles.

(7)

REGULATIONS
Road Traffic and Transport Act 22 of 1999
Road Traffic and Transport Regulations, 2001

[subregulation (7) deleted by GN 205/2004]

(8) The vehicle testing station must advise the registering authority in whose area of jurisdiction that vehicle testing station is situated that the roadworthy certificate is void and must send the roadworthy certificate concerned to the registering authority.

Period of validity of roadworthy certificate

160. A roadworthy certificate issued in respect of a motor vehicle contemplated in regulation 157 is valid from the date of issue thereof until the date on which the licence disc issued in respect of the motor vehicle concerned becomes void as referred to in regulation 29 or expires in terms of regulation 33.

[regulation 160 substituted by GN 205/2004]

161.

[regulation 161 deleted by GN 205/2004]

Right of appeal to Minister

162. (1) Any person who is aggrieved at the refusal of a vehicle examiner or a vehicle testing station to certify that a motor vehicle is roadworthy or at the refusal of a registering authority to issue a roadworthy certificate, may, within 21 days after such refusal, in writing appeal against any such refusal or the conditions concerned to the Commission and that person must at the same time serve a copy of the appeal on the vehicle examiner, vehicle testing station or registering authority concerned.

(2) After receipt of the copy of the appeal referred to in subregulation (1), the vehicle examiner, testing station or registering authority concerned must forthwith furnish the Commission with the reasons for the refusal to which such appeal relates.

(3) For the purpose of deciding an appeal in terms of subregulation (1), the Commission may -

- (a) cause the motor vehicle concerned to be examined and tested by a vehicle examiner nominated by him or her at an appropriately graded vehicle testing station; and
- (b) require each party to such appeal to furnish such information and evidence as he or she considers necessary.

(4) The Commission may after due consideration of the appeal give such decision as he or she considers appropriate.

[Regulation 162 amended by GN 205/2004 to substitute "Commission" for "Minister" throughout. In subregulation (3)(a), this change should also include a substitution of the word "it" for the words "him or her". In subregulation (4) this change should also include a substitution of the word "it" for the words "he or she".]

Notice to direct that motor vehicle be taken to vehicle testing station

REGULATIONS
Road Traffic and Transport Act 22 of 1999
Road Traffic and Transport Regulations, 2001

163. (1) A licence inspector, vehicle examiner or traffic officer may issue a notice to discontinue operation of a motor vehicle on the approved form and to direct that the motor vehicle must be produced at a vehicle testing station for inspection, examination or testing.

(2) The notice must -

- (a) specify the vehicle testing station to which the vehicle shall be taken; and
- (b) indicate the period within which the vehicle shall be taken to the vehicle testing station, but the period may not exceed 14 days.

(3) The licence inspector, vehicle examiner or traffic officer concerned shall ensure that the particulars of the motor vehicle concerned is updated in the register of motor vehicles referred to in regulation 366(6)(a), to the effect that a notice has been issued in terms of this regulation with respect to the vehicle and that the inspector examiner or officer is of the opinion that the vehicle does not comply with the requirements for certification of roadworthiness.

(4) The licence inspector, vehicle examiner or traffic officer concerned shall forward a copy of the notice to the vehicle testing station referred to in subregulation (2)(a).

(5) The motor vehicle concerned shall be taken, accompanied by the notice, to the said vehicle testing station within the period referred to in subregulation (2)(b) to have that notice revoked.

(6) In addition to the notice issued in terms of subregulation (1), the licence inspector, vehicle examiner or traffic officer concerned, must remove the licence disc pertaining to that motor vehicle from that motor vehicle, and forward it to the vehicle testing station concerned together with the copy of the notice referred to in subregulation (4).

Procedure after issue of notice in terms of regulation 163

164. (1) The vehicle examiner at the said vehicle testing station shall inspect, examine or test the vehicle free of charge, and shall -

- (a) if the vehicle is found to be unroadworthy, destroy the licence disc or licence and roadworthy certificate disc in force in respect of such vehicle, complete the notice or a copy of it, and return it to the traffic officer, vehicle examiner or licence inspector; or
- (b) if the vehicle is found to be roadworthy, cancel the notice, return the licence disc to the owner of the motor vehicle and notify the licence inspector, vehicle examiner or traffic officer accordingly.

(2) The licence inspector, vehicle examiner or traffic officer shall ensure that the particulars of the motor vehicle is updated in the register of motor vehicles referred to in regulation 366(6)(a) to the effect -

[The verb “is” should be “are” to accord with the subject “particulars”.]

- (a) where subregulation (1)(a) applies, or if no reaction has been received with respect to the notice for a period of 35 days from the date of issue of it, that the motor vehicle is unroadworthy; or

REGULATIONS
Road Traffic and Transport Act 22 of 1999
Road Traffic and Transport Regulations, 2001

- (b) where subregulation (1)(b) applies, that the notice issued in terms of subregulation (1), has been cancelled.

PART 3
EQUIPMENT ON OR IN RESPECT OF VEHICLES

Brakes on motor vehicle other than motorcycle or trailer

165. (1) A person may not operate on a public road a motor vehicle, other than a motorcycle or trailer, which is not equipped with a service brake, a parking brake and an emergency brake, but -

- (a) the emergency brake and parking brake may be one and the same brake; and
- (b) in the case of -
 - (i) a motor vehicle which is equipped with a service brake consisting of two braking systems, that brake is, when the systems brake the wheels independently, deemed to be an emergency brake;
 - (ii) a steam or electrically driven motor vehicle of which the engine or motor can be reversed, the reversing mechanism may be used instead of an emergency brake; and
 - (iii) a tractor, the brakes may be so constructed that the service brake may be used as a parking brake.

(2) A person may not operate on a public road a motor vehicle which, according to its registration certificate, was registered for the first time on or after 1 July 2002, to which is fitted an anti-theft device which is connected to or in any way interferes with the braking system of the motor vehicle.

Brakes on motorcycle

166. A person may not operate on a public road a motorcycle which is not equipped with two independent braking systems, one of which must act on the front wheel or wheels and the other which must act on the rear wheel or wheels and each of the systems must have an efficiency at least equivalent to that specified for an emergency brake and when the two systems are applied simultaneously, the combined efficiency must be at least equivalent to that specified for a service brake.

Brakes on trailers

167. (1) Subject to subregulation (4), a person may not operate a trailer on a public road if -

- (a) the mass of the trailer and any load thereon is 750 kilograms or less and -
 - (i) does not exceed half of the tare of the drawing vehicle, unless that trailer is equipped with at least a parking brake or other device for keeping that trailer stationary; or

REGULATIONS
Road Traffic and Transport Act 22 of 1999
Road Traffic and Transport Regulations, 2001

- (ii) exceeds half of the tare of the drawing vehicle but does not exceed such tare, unless that trailer is equipped with a parking brake and either an overrun brake or a service brake;
- (b) the gross vehicle mass of the trailer exceeds 750 kilograms but does not exceed 3500 kilograms and does not exceed the tare of the drawing vehicle, unless that trailer is equipped with a parking brake and either an overrun brake or a service brake; or
- (c) the gross vehicle mass of the trailer exceeds the tare of the drawing vehicle or 3500 kilograms, as the case may be, unless that trailer is equipped with a parking brake and a service brake, and where more than one trailer is drawn by a drawing vehicle, the foregoing requirements applies in respect of each such trailer, and in such event the gross vehicle mass must be construed as the total of the gross vehicle masses of all trailers so drawn.

[The verb “applies” should be “apply” to accord with the subject “requirements”.]

(2) The service brake of a trailer must be capable of being operated by the driver of the drawing vehicle while that trailer and drawing vehicle are in motion.

(3) If the service or overrun brake of a trailer is capable of being used as a parking brake, a separate parking brake need not be fitted to that trailer.

(4) If a trailer referred to in subregulation 1(c), is drawn by a tractor and the tractor is not designed for or capable of operation at a speed exceeding 35 kilometres per hour on a reasonably level road, that trailer may be equipped with an overrun brake in lieu of a service brake referred to in subregulation (a).

Brakes on pedal cycles

168. A person may not operate on a public road any pedal cycle unless it is equipped with at least one brake that operates on the rear wheel or wheels.

Brakes on unspecified vehicles

169. A person may not operate on a public road any vehicle for which brakes are not specified elsewhere in regulations 165 to 172 inclusive, unless the vehicle is equipped with a parking brake or other device for keeping it stationary.

Specifications for brakes

170. (1) Subject to subregulation (2), a person may not, after 1 January 2002, operate on a public road a goods vehicle, with a gross vehicle mass which exceeds 3 500 kilograms, a minibus, bus or tractor which was registered for the first time on or after 1 January 1986, unless the brakes fitted thereto comply with the Standard Specification SABS 1207: 1985 “Motor vehicle safety standard specification for braking” published by the South African Government Notice No. 6 of 3 January 1986 or the Standard Specification SABS 1051: 1980 “Motor vehicle safety specification for braking” published by the South African Government Notice No. 463 of 9 July 1982.

REGULATIONS
Road Traffic and Transport Act 22 of 1999
Road Traffic and Transport Regulations, 2001

(2) A person may not operate on a public road a tractor which is not designed for or capable of operating at a speed exceeding 35 kilometres per hour on a reasonably level road, or a trailer drawn by such tractor -

- (a) which is registered for the first time on or after 1 January 2002; and
- (b) irrespective of the date of registration, after 1 January 2004,

unless the brakes fitted to the tractor or trailer comply with the Standard Specification SABS 1447 "Motor vehicle safety specification for braking (motor and towed vehicles, designed for low speed or for use off public roads)" Part 1: 1988 "Tractors" and Part 2: 1988 "Trailers", published by the South African Government Notice No. 1652 of 19 August 1988, or the Standard Specification SABS 1207:1994 "Motor vehicle safety standard specification for braking" published by the South African Government Notice No. 6 of 3 January 1986 or the Standard Specification SABS 1051: 1980 "Motor vehicle safety specification for braking" published by the South African Government Notice No. 463 of 9 July 1982.

Braking performance of service, emergency and parking brakes

171. (1) A person may not operate on a public road a motor vehicle or a combination of motor vehicles which, in terms of these regulations -

- (a) must be equipped with a service brake, unless such brake at all times -
 - (i) in the case of a motor vehicle or a combination of motor vehicles, capable of exceeding a speed of 35 kilometres per hour, when it is applied from an initial speed of 35 kilometres per hour, complies with the requirements for braking performance set out in Table A hereunder; or
 - (ii) in the case of a motor vehicle or a combination of motor vehicles, not capable of exceeding a speed of 35 kilometres per hour, when it is applied from the maximum speed which the motor vehicle or combination is capable of attaining, complies with the requirements for braking performance set out in Table B hereunder;
- (b) must be equipped with an emergency brake, unless such brake at all times -
 - (i) in the case of a motor vehicle or a combination of motor vehicles, capable of exceeding a speed of 3.5 kilometres per hour, when it is applied from an initial speed of 35 kilometres per hour, complies with the requirements for braking performance set out in Table C hereunder; or
 - (ii) in the case of a motor vehicle or a combination of motor vehicles, not capable of exceeding a speed of 35 kilometres per hour, when it is applied from the maximum speed which the motor vehicle or combination is capable of attaining, complies with the requirements for braking performance set out in Table D hereunder; or
- (c) must be equipped with a parking brake, unless such brake, at all times, is capable of keeping the motor vehicle or combination stationary for an indefinite period with the engine disengaged on a gradient of not more than one in 8.33.

REQUIREMENTS FOR BRAKING PERFORMANCE

REGULATIONS
Road Traffic and Transport Act 22 of 1999
Road Traffic and Transport Regulations, 2001

TABLE A

SERVICE BRAKE OF MOTOR VEHICLE OR COMBINATION OF MOTOR VEHICLES CAPABLE OF EXCEEDING SPEED OF 35 km/h

	Initial speed in km/h	Maximum stopping distance in metres	Minimum deceleration in m/s ²	Minimum equivalent braking force in N/kg
Light motor vehicle	35	14	4,4	4,4
Heavy motor vehicle	35	16	4,4	4,4

TABLE B

SERVICE BRAKE OF MOTOR VEHICLE OR COMBINATION OF MOTOR VEHICLES NOT CAPABLE OF EXCEEDING SPEED OF 35 km/h

Maximum initial speed in km/h	Maximum stopping distance in metres	Minimum deceleration [deceleration] in m/s ²	Minimum equivalent braking force in N/kg
15	7	1,9	1,9
20	11	1,9	1,9
25	16	1,9	1,9
30	23	1,9	1,9
35	30	1,9	1,9

TABLE C

EMERGENCY BRAKE OF MOTOR VEHICLE OR COMBINATION OF MOTOR VEHICLES CAPABLE OF EXCEEDING SPEED OF 35 km/h

	Initial speed in km/h	Maximum stopping distance in metres	Minimum deceleration in m/s ²	Minimum equivalent braking force in N/kg
Light or heavy motor vehicle	35	30	19	19

TABLE D

EMERGENCY BRAKE OF MOTOR VEHICLE OR COMBINATION OF MOTOR VEHICLES NOT CAPABLE OF EXCEEDING SPEED OF 35 km/h

REGULATIONS
Road Traffic and Transport Act 22 of 1999
Road Traffic and Transport Regulations, 2001

Maximum initial speed in km/h	Maximum stopping distance in metres	Minimum deceleration [deceleration] in m/s ²	Minimum equivalent braking force in N/kg
15	12	1,95	1,95
20	20	1,95	1,95
25	29	1,95	1,95
30	41	1,95	1,95
35	55	1,95	1,95

[Tables A-D amended by GN 98/2016 to correct a typographical error which actually appeared only in Tables A and C.]

(2) Compliance with the requirements contemplated in subregulation (1)(a) and (b) is determined by -

- (a) actual road tests conducted on a road with a reasonably level, dry, smooth and hard surface which is free from loose material and with the stopping distance measured from the moment the particular brake is applied with the engine disengaged until the vehicle comes to rest;
- (b) a suitable mechanical test; or
- (c) both tests contemplated in paragraphs (a) and (b),

(3) When testing a brake on a combination of motor vehicles, the brakes of the drawn vehicle or vehicles must be applied at the same moment as the brakes of the drawing vehicle,

(4) Where in any prosecution for a contravention of subregulation (1) the question arises whether a motor vehicle or a combination of motor vehicles travelled at a particular speed, the speed indicated by the speedometer of the vehicle or combination is, until the contrary is proved, deemed to be correct.

(5) For the purposes of this regulation -

- (a) “light motor vehicle” means -
 - (i) a motor car;
 - (ii) a motor vehicle with a gross vehicle mass not exceeding 3 500 kilograms; or
 - (iii) any other motor vehicle with a tare not exceeding 3 500 kilograms, but does not include a bus, minibus or goods vehicle; and
- (b) “heavy motor vehicle” means a motor vehicle which is not a light motor vehicle.

Condition and operation of brakes

172. (1) A brake required in terms of these regulations must -

- (a) be in good working order and condition whenever the vehicle to which it is fitted is operated on a public road; and

REGULATIONS
Road Traffic and Transport Act 22 of 1999
Road Traffic and Transport Regulations, 2001

- (b) when tested in terms of regulation 171, except in the case of a motorcycle with side-car, act with approximately equal intensity on the wheels symmetrically placed in relation to the longitudinal centre-line of the vehicle.

(2) A person may not operate on a public road a motor vehicle equipped with a service brake which is operated solely by air or vacuum pressure unless there is fitted in the driving compartment of the motor vehicle a device (other than a gauge indicating pressure) whereby the driver of that motor vehicle is given visible or audible warning when the air or vacuum pressure is incorrect but before the pressure becomes such that the brake is incapable of stopping that motor vehicle as contemplated in regulation 171.

(3) If a drawn vehicle is equipped with a service brake operated solely by air or vacuum pressure, the device referred to in subregulation (2) must be fitted in the driving compartment of the drawing vehicle.

Vehicles to be equipped with certain lamps and times when certain lamps must be switched on

173. (1) A person may only operate a motor vehicle on a public road if -

- (a) all lamps fitted to the motor vehicle as contemplated in this regulation to regulation 202 inclusive, are undamaged, properly secured, and capable of being switched on at all times; and
- (b) the headlamps, rear lamps and number plate lamps are kept on during the period between sunset and sunrise and at any other time when, due to insufficient light or unfavourable weather conditions, persons and vehicles upon the public road would not be clearly discernible at a distance of 150 metres, but this paragraph does not apply to a motor vehicle parked off the roadway of a public road or in a parking place demarcated by appropriate road traffic signs or within a distance of 12 metres from a lighted street lamp illuminating the public road on which the motor vehicle is parked.

**[subregulation (1) amended by GN 205/2004 to substitute
 "number plate lamps" for "licence plate lamps"]**

(2) A person may only operate on a public road a motorcycle, with or without a side-car, if its headlamp or lamps are switched on at all times, but this subregulation does not apply to a motorcycle, with or without a side-car, manufactured before 31 December 1960, which was not manufactured with lamps.

(3) A person operating a motor vehicle on a public road must dip the main beam of the light emitted by the headlamp of the motor vehicle if the main beam could cause a dangerous glare to oncoming traffic.

Visibility distance of lights

174. (1) Where provision is made in regulations 173 to 202 inclusive, as to the distance from which certain lights and devices must render objects visible or the distance within which such lights or devices must be visible, such provision applies during the period between sunset and sunrise and at any other time when, due to insufficient light or unfavourable weather conditions, persons and vehicles upon the public road are not clearly discernible at a distance of

REGULATIONS
Road Traffic and Transport Act 22 of 1999
Road Traffic and Transport Regulations, 2001

150 metres, in respect of a vehicle without load when upon a straight, reasonably level, unlighted public road in clear weather, unless a different time or condition is expressly stated.

(2) Every lamp required to be fitted to or to be used in connection with any vehicle in terms of these regulations must emit a light of sufficient brilliance to be visible from a distance of at least 150 metres to a person of normal eyesight.

Headlamps

- 175.** (1) A person may only operate on a public road -
- (a) a motor vehicle, other than a motorcycle, motor tricycle with one wheel in front or trailer if it is equipped in front on each side of its longitudinal centre-line with -
 - (i) one headlamp capable of emitting a main beam and a dipped beam;
 - (ii) one headlamp capable of emitting a main beam and one headlamp capable of emitting a dipped beam; or
 - (iii) one headlamp contemplated in subparagraph (i) or headlamps contemplated in subparagraph (ii) and an additional headlamp capable of emitting a main beam;
 - (b) a motorcycle without a side-car or a motor tricycle with one wheel in front, if it is equipped in front with -
 - (i) one headlamp capable of emitting a main beam and a dipped beam;
 - (ii) one head lamp capable of emitting a main beam and one headlamp capable of emitting a dipped beam, both of which are fitted on the same vertical plane; or
 - (iii) two headlamps each capable of emitting a main beam and a dipped beam, both of which are fitted on the same horizontal plane; or
 - (c) a motorcycle with a side-car, if -
 - (i) the motorcycle is equipped in front with one headlamp contemplated in paragraph (b)(i) or headlamps contemplated in paragraph (b)(ii) or (iii); and
 - (ii) the side-car is equipped with one parking lamp complying with regulation 181 or with one headlamp contemplated in paragraph (b)(i), but subject to the proviso to regulation 177(4)(a).

(2) At least one headlamp contemplated in subregulation (1)(a) capable of emitting a dipped beam or a parking lamp complying with regulation 181 must be so fitted on each side of the longitudinal centre-line of the motor vehicle concerned that the portion of the illuminating surface thereof furthest from the longitudinal centre-line of the motor vehicle is not more than 400 millimetres from the outer edge of the front of the motor vehicle.

(3) The mainbeam and dipped beam of a headlamp fitted to a motor vehicle first registered on or after 1 January 2002, must comply with the requirements of standard specification of the South African Bureau of Standards, SABS 1046 "Motor vehicle safety specification for

REGULATIONS
Road Traffic and Transport Act 22 of 1999
Road Traffic and Transport Regulations, 2001

lights and light signalling devices installed on motor vehicles and trailers”, and standard specification SABS 1376 “Lights for motor vehicles”, Part 2: “Head lights”.

Main beam

176. Every headlamp emitting a main beam or light must be so adjusted and maintained that -

- (a) it must be capable of adequately illuminating an area ahead of the motor vehicle concerned, enabling the driver to see any person, vehicle or substantial object at a distance of at least 100 metres ahead; and
- (b) it can be extinguished by the use of a device which simultaneously must cause or allow the dipped beam of light to be emitted or continue to be emitted from a headlamp.

Dipped beam

177. (1) Every headlamp emitting a dipped beam of light which, when projected onto a vertical screen, shows a beam pattern with a sharp, clearly defined cut-off line diagonal to the left (hereafter referred to as the “diagonal cut-off line”) and horizontal to the right (hereafter referred to as the “horizontal cut-off line”), must be so adjusted and maintained that, when the motor vehicle concerned is on a reasonably level road, that beam at the horizontal cut-off line must -

- (a) slant downwards at a percentage inclination of at least 0,5 percent, which percentage inclination must be calculated in accordance with the formula - $(h_1 - h_2) \times 100$; and
 - (b) strike the road surface ahead of the motor vehicle within a distance in metres calculated in accordance with the formula - $200 \times h_1$
- (2) In the formulae referred to in subregulation (1) -
- (a) “ h_1 ” represents the height in metres of the headlamp measured to the centre of the headlamp vertically from ground level;
 - (b) “ h_2 ” represents the height in metres of the horizontal cut-off line measured vertically from ground level at the screen contemplated in subregulation (1); and
 - (c) “ L ” represents the distance in metres of the screen contemplated in subregulation (1) measured horizontally from the headlamp as illustrated hereunder.

REGULATIONS
Road Traffic and Transport Act 22 of 1999
Road Traffic and Transport Regulations, 2001

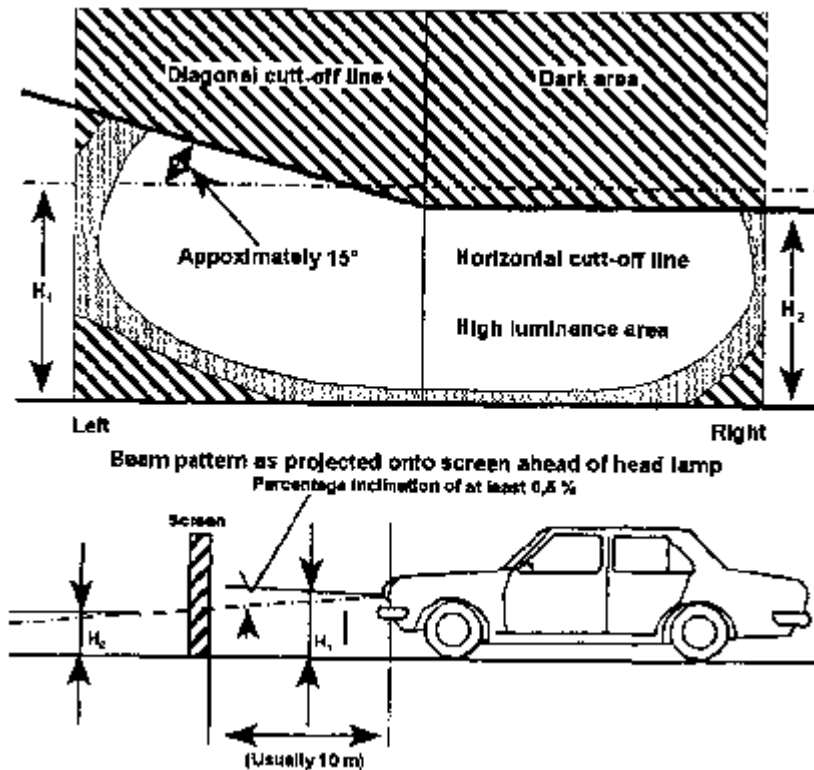

(3) Every headlamp emitting a dipped beam or light which, when projected onto a vertical screen, shows a symmetrical light pattern or does not have a diagonal and horizontal cut-off line, must be so adjusted and maintained that when the motor vehicle concerned is on a reasonably level road, the centre of the intense part of that beam must slant downwards to strike the road surface ahead of the motor vehicle within a distance not exceeding 45 metres.

- (4) Every headlamp emitting a dipped beam must be so adjusted and maintained that -
- (a) it must be capable of adequately illuminating an area ahead of the motor vehicle concerned, enabling the driver to see any person, vehicle or substantial object at a distance of at least 45 metres ahead of the motor vehicle, but this paragraph does not apply to a headlamp emitting a dipped beam of light, fitted to the side-car of a motorcycle;
 - (b) it does not cause a dangerous glare to oncoming traffic on a reasonably level road; and
 - (c) in the case where -
 - (i) a dipped beam shows a light-pattern as contemplated in subregulation (1), the intersection of the diagonal and horizontal cut-off lines; or
 - (ii) a dipped beam shows a light-pattern as contemplated in subregulation (3), the centre of the intense part of such beam, must not deflect to the right

Daytime running lamp

178. (1) A motor vehicle, except a trailer, may be fitted with daytime running lamps.

REGULATIONS
Road Traffic and Transport Act 22 of 1999
Road Traffic and Transport Regulations, 2001

- (2) Daytime running lamps must be fitted -
 - (a) not less than 250 millimetres or more than one comma five metres above the ground level; and
 - (b) towards the front of the motor vehicle in such a manner that the light emitted from that lamp does not cause discomfort to the driver, either directly or indirectly through any of the rear-view mirrors or any other reflecting surface of that vehicle.
- (3) Daytime running lamps must be connected in such a manner -
 - (a) that the rear lamps are on at the same time as the daytime running lamps; and
 - (b) that they switch off automatically when the headlamps are switched on, except when the headlamps are wired to give intermittent luminous warnings at short interval.
- (4) A person driving a motor vehicle during the day on the public road outside urban area must switch on the headlamps on dipped beam or daytime running lamps.

[Subregulation (4) is inserted by GN 156/2015 and substituted by GN 98/2016. The word "an" appears to have been omitted before the term "urban area".]

Lights to be displayed on stationary or parked motor vehicle

179. A person may not stop or park a motor vehicle on a public road during the period between sunset and sunrise and at any other time when, due to insufficient light or unfavourable weather conditions, persons and vehicles upon the public road are not clearly discernible at a distance of 150 metres unless -

- (a) the headlamps thereof emit a dipped beam of light complying with regulation 177 or a beam of light complying with regulation 181 is emitted from parking lamps incorporated in such headlamps; or
- (b) if the headlamps thereof are extinguished, light is emitted from two fog lamps or parking lamps complying with regulations 180 and 181 respectively.

Fog lamps

180. (1) A motor vehicle may be equipped at the front and at the rear or at the front or at the rear with -

- (a) one fog lamp; or
- (b) two fog lamps, one on each side of the longitudinal centre-line of the motor vehicle.

(2) A person may not operate a motor vehicle on a public road if the motor vehicle, in terms of subregulation (1), is equipped with a fog lamp or fog lamps, unless -

- (a) every fog lamp at the front is so adjusted and maintained that it is only capable of emitting a dipped beam of light complying with regulation 177(3) and (4); or

REGULATIONS
Road Traffic and Transport Act 22 of 1999
Road Traffic and Transport Regulations, 2001

- (b) the fog lamp or lamps at the rear can only be brought into operation when any fog lamp at the front or any headlamp of that motor vehicle is brought into operation.
- (3) If a fog lamp contemplated in subregulation (1) is fitted -
 - (a) at the front of a motor vehicle, it must be fitted with the highest point of its illuminating surface above the highest point of the illuminating surface of a headlamp emitting a dipped beam of light; or
 - (b) at the rear of a motor vehicle, it must be fitted with the lowest point of its illuminating surface less than 250 millimetres and the highest point thereof more than one metre from ground level.
- (4) If -
 - (a) a motor vehicle, other than a motorcycle (excluding a motor quadrucycle) is, in terms of subregulation (1)(a) equipped with one fog lamp at the front, then a parking lamp or parking lamps complying with regulation 181, must be fitted to the motor vehicle in such a manner that every parking lamp must be brought into operation simultaneously with the fog lamp; or
 - (b) a motor vehicle is in terms of subregulation (1)(b) equipped with two fog lamps at the front and any such lamp is so placed that the portion of its illuminating surface which is furthest from the longitudinal centre-line of the motor vehicle is further than 400 millimetres from the outer edge of the front of such vehicle, then a parking lamp or parking lamps complying with regulation 181 must be fitted to the motor vehicle in such a manner that every parking lamp must be brought into operation simultaneously with the fog lamps.
- (5) A fog lamp may not be fitted to the side-car of a motorcycle (excluding a motor tricycle or motor quadrucycle) at the front, unless it is equipped with a fog lamp complying with this regulation or with a parking lamp complying with regulation 181 and which can be brought into operation simultaneously with the fog lamp on the side-car, but if a fog lamp is only fitted to the motorcycle at the front, the side-car must be equipped with one parking lamp referred to in regulation 175(1)(c) and that parking lamp must be capable of being brought into operation simultaneously with that fog lamp.
- (6) A person may not operate a motor vehicle on a public road while any fog lamp fitted to the motor vehicle is lit, except in conditions of poor visibility caused by snow, fog, mist, dust or smoke.

Parking lamps

- 181.** (1) A motor vehicle may be equipped -
 - (a) in front with one or two parking lamps which must be visible directly from the front;
 - (b) at the rear with one or two parking lamps which must be visible directly from the rear; or

REGULATIONS
Road Traffic and Transport Act 22 of 1999
Road Traffic and Transport Regulations, 2001

- (c) at each side with one parking lamp which must be visible directly from the front and from the rear.
- (2) Any parking lamp -
 - (a) contemplated in subregulation (1)(a), may form part of a headlamp referred to in regulation 175, a fog lamp referred to in regulation 180 or a front position lamp referred to in regulation 183; or
 - (b) contemplated in subregulation (1)(b), may form part of a fog lamp referred to in regulation 180, a rear lamp referred to in regulation 185 or a stop lamp referred to in regulation 186.
- (3) If a motor vehicle is, in terms of subregulation (1), equipped at the front or at the rear with -
 - (a) one parking lamp, that lamp must be fitted on the right side of the motor vehicle; or
 - (b) two parking lamps, one parking lamp must be fitted on each side of the longitudinal centre-line of the motor vehicle,

so that the portion of the illuminating surface thereof furthest from the longitudinal centre-line of the motor vehicle is not further than 400 millimetres from the outer edge of the front or rear of the motor vehicle, as the case may be, but in the case of a motor vehicle registered prior to 1 July 1990 the portion of illuminating surface of the parking lamp furthest from the longitudinal centre-line of the motor vehicle may not be further than 500 millimetres from the outer edge of the front or rear of the motor vehicle.

When parking lamps are to be kept lighted

182. (1) A person may only operate a motor vehicle on a public road if, on any side of the longitudinal centre-line of the motor vehicle no headlamp in use is so placed that the portion of its illuminating surface furthest from that centre-line is within 400 millimetres from the outer edge of the front of the motor vehicle, unless a parking lamp fitted to that side of the vehicle and complying with regulation 181, is kept lighted.

(2) A person may not operate on a public road a motor vehicle of which only the parking lamps are lighted while the motor vehicle is in motion.

Front position lamps

183. (1) A person may not operate a motor vehicle or a combination of motor vehicles, other than a motorcycle on a public road, if any of the outer edges of the widest part of the motor vehicle or combination of motor vehicles or any load thereon projects more than 400 millimetres beyond the illuminating surface of any outermost lamp to the front of that motor vehicle or combination of motor vehicles which is nearest to such edge, unless there is fitted on each side of the widest part one front-position lamp which must be visible directly from the front.

- (2) The front position lamps contemplated in subregulation (1) -
 - (a) must be fitted as near as possible to, but not more than 400 millimetres, or in the case of a trailer, converter dolly or adaptor dolly, not more than 150 millimetres,

REGULATIONS
Road Traffic and Transport Act 22 of 1999
Road Traffic and Transport Regulations, 2001

from the outer edges of the widest part of the motor vehicle or combination of motor vehicles concerned or any load thereon, and may not be less than 350 millimetres or more than two comma one metres above the ground level, but a motor vehicle first registered prior to 1 January 1985 may have such lamps fitted less than 350 millimetres above the ground but such lamps must be fitted as high as possible; and

- (b) must emit a white light.

End-outline-marker lamps

184. (1) A motor vehicle may be equipped -

- (a) in front on each side of its longitudinal centre-line with one end-outline-marker lamp which must be visible directly from the front; and
- (b) at the rear on each side of its longitudinal centre-line with one end-outline-marker lamp which must be visible directly from the rear.

(2) The end-outline-marker lamps contemplated in subregulation (1) -

- (a) must be fitted as near as possible to the outer edges of the front and rear of the motor vehicle and as high as possible; and
- (b) must emit a white light to the front and a red light to the rear.

Rear lamps

185. (1) A person may not operate a motor vehicle on a public road, excluding a motor vehicle which was first registered before 1 January 1981, or a motorcycle other than a motor quadrucycle, unless it is fitted with at least one lamp on each side at the rear -

- (a) emitting a red light to the rear, of minimum intensity of two candelas;
- (b) positioned not more than 400 millimetres from the outer edges of the widest part of the motor vehicle; and
- (c) positioned not lower than 350 millimetres or higher than one and a half metres above ground level, but if due to the structure of the motor vehicle it is impossible or impractical to position the lamps within one and a half metres above ground level the lamps may be positioned as near as possible but not higher than two comma one metres above ground level.

(2) A motorcycle excluding a motor quadrucycle or motor vehicle first registered prior to 1 January 1981, may be fitted with rear lamps in the positions as are prescribed in subregulation (1), but must be fitted with at least one such lamp at the rear, emitting a red light to the rear with a minimum intensity of two candelas, positioned in the centre or to the right of the longitudinal centre-line of the motor vehicle at a height of not less than 300 millimetres and not more than two comma one metres above the ground level.

(3) Rear lamps fitted to a motor vehicle, in addition to those prescribed in this regulation, may be fitted higher than two comma one metres, above ground level.

REGULATIONS
Road Traffic and Transport Act 22 of 1999
Road Traffic and Transport Regulations, 2001

(4) A motor vehicle which is towed by a breakdown vehicle must be fitted with a separate temporary set of rear lamps while the motor vehicle is being towed.

Stop lamp

186. (1) A person may not operate a motor vehicle, including a motor tricycle or motor quadrucycle, but excluding a tractor or a trailer drawn by a tractor, on a public road unless it is fitted with at least one stop lamp on each side at the rear of the motor vehicle or a motorcycle, unless it is fitted with one stop lamp at the rear, and the stop lamp must -

- (a) be visible from the rear and must be unobscured within angles of -
 - (i) 45 degrees measured across the width of the motor vehicle on either side of a line parallel to the longitudinal centre-line of the motor vehicle and passing through the centre-line of each stop lamp; and
 - (ii) 15 degrees measured vertically on either side of a horizontal line parallel to the longitudinal centre-line of the motor vehicle and passing through the centre-line of each stop lamp, but if the height of the stop lamp above ground level is less than 750 millimetres, such angles, measured below such horizontal line, may be reduced to five degrees;
- (b) be fitted at a height of not less than 300 millimetres and not more than two comma one metres above ground level, measured to the centre of the lamp, but any additional stop lamps may be fitted above two comma one metres;
- (c) be fitted equidistant from, and on each side of, the longitudinal centre-line of such motor vehicle;
- (d) when in use, emit a red light of which the intensity must be greater than that of the light emitted by the rear lamp on the motor vehicle and must be visible in normal sunlight at a distance of not less than 30 metres to a person of normal eyesight;
- (e) be so connected that, if the motor vehicle is in motion, the lamp comes into operation as soon as the operating device of the service brake or similar brake of the motor vehicle or, in the case of a combination of motor vehicles, of the drawing vehicle, is activated; and
- (f) be maintained in a clean condition and in good working order.

(2) A motor vehicle, which is being towed by a breakdown vehicle, must be fitted with a separate temporary set of stop lamps which is co-ordinated with the working of the stop lamps of the breakdown vehicle while the motor vehicle is so towed.

(3) A stop lamp complying with subregulation (1) may be incorporated in a rear lamp fitted to a motor vehicle in terms of regulation 185.

(4) For the purpose of this regulation, "motorcycle" does not include a motor tricycle or motor quadrucycle.

Number plate lamp

REGULATIONS
Road Traffic and Transport Act 22 of 1999
Road Traffic and Transport Regulations, 2001

187. (1) A person may not operate a motor vehicle, other than a tractor, on a public road unless it is fitted with at least one number plate lamp at the rear, illuminating the number plate or identification card by means of a white light which must make every letter and figure of the plate or card plainly distinguishable from a distance of at least 20 metres by a person of normal eyesight, but a number plate lamp need not be kept lighted on a motor vehicle parked on a public road.

(2) The beam of light of a number plate lamp may not be directed to the rear.

Side marker lamps

188. (1) Any motor vehicle or combination of motor vehicles may, but a breakdown vehicle must, be fitted with side marker lamps along each side which, when in operation, must emit a diffused yellow light, and -

- (a) the side marker lamp furthest forward on the motor vehicle, combination of motor vehicles or breakdown vehicle, when in operation, may emit a diffused white or amber light; and
- (b) the rearmost side marker lamp on a motor vehicle, combination of motor vehicles or breakdown vehicle, when in operation, may emit a diffused red or amber light

(2) Side marker lamps must be so placed that -

- (a) there is a lamp within 400 millimetres of each end of the body of each vehicle;
- (b) the distance between successive lamps on any motor vehicle or combination of motor vehicles is not more than three comma six metres;
- (c) they are not less than 300 millimetres from the ground: and
- (d) they face directly outwards from the side to which they are fitted in a direction at right angles to the longitudinal centre-line of the vehicle to which they are fitted.

Interior lamp

189. A lamp emitting a diffused light may be provided on any motor vehicle for the purpose of illuminating the interior, including the instrument panel thereof or any entrance thereto.

Lamp illuminating notice on motor vehicle

190. (1) A lamp illuminating a notice relating to the destination of a motor vehicle or its availability for hire may be fitted to any motor vehicle.

(2) A lamp illuminating a notice or token indicating the use of a motor vehicle as an ambulance, blood transfusion service, fire-fighting, police, traffic-control vehicle or a patrol vehicle of any approved security service, crime prevention agency or other agency, may be fitted to that vehicle.

Decorating lamp

REGULATIONS
Road Traffic and Transport Act 22 of 1999
Road Traffic and Transport Regulations, 2001

191. For the purpose of decorating a vehicle taking part in a procession, a lamp, other than a spot lamp may be fitted to it.

Reversing lamp

192. (1) A motor vehicle may be fitted with a reversing lamp, emitting a white light, which illuminates the road to the rear of or under the vehicle.

(2) A reversing lamp must be under the direct control of the driver and must be either so fitted as to operate only when the motor vehicle is placed in reverse gear or be connected with a device by which the driver must be made aware that the lamp is in operation.

(3) Not more than two reversing lamps may be fitted to a vehicle and no light may emit therefrom except when the vehicle is being reversed or is about to be reversed.

Inspection lamps

193. An inspection lamp may be carried on or fitted to a vehicle, but may only emit a light when actually in use for the purpose of carrying out repairs or inspections.

Identification lamps

194. (1) A bus or a goods vehicle, with a gross vehicle mass which exceeds 3 500 kilograms, and which is not a motor vehicle referred to in subregulation (2), (3) or (5), may be fitted above the windscreen with two or more identification lamps and each such lamp must -

- (a) not exceed a capacity of 21 Watts;
- (b) be visible from directly in front of the motor vehicle to which it is fitted; and
- (c) emit a green or amber light.

(2) Only an emergency service vehicle, other than a civil defence or a security service vehicle, may be fitted with a lamp or lamps emitting an intermittently flashing red light in any direction

(3) Only a motor vehicle operated by a member of the Namibian Police, a traffic officer, road transport inspector, a member of the Military Police referred to in the Defence Act, 2002 (Act No.1 of 2002) or a member of the Correctional Service, in the execution of his or her duties, may be fitted with or display a lamp or lamps emitting a blue light.

[subregulation (3) substituted by GN 98/2016]

(4) A motor vehicle referred to in subregulation (3) may be fitted with a lamp or lamps emitting an intermittently-flashing in any direction a blue, white, red or amber light or a combination of those lights as approved by the Minister and which may, at the will of the driver, display a word as approved by the Minister.

- (5) A motor vehicle that is -
 - (a) a vehicle employed in connection with the maintenance of a public road;
 - (b) engaged in the distribution and supply of electricity;

REGULATIONS
Road Traffic and Transport Act 22 of 1999
Road Traffic and Transport Regulations, 2001

- (c) engaged in the supply of other essential public services;
- (d) operated in terms of the authority granted by the Minister in terms of section 99 of the Act;
- (e) a breakdown vehicle;
- (f) a refuse compactor vehicle;
- (g) a vehicle carrying an abnormal load and the vehicle escorting it if any,

may, but a breakdown vehicle must, be fitted with a lamp or lamps capable of emitting an intermittently-flashing amber light in any direction, but that lamp must only be used at the place where the breakdown occurred, where the maintenance or other work or any inspection is being carried out, when that breakdown vehicle is towing a motor vehicle or in the event of a vehicle carrying an abnormal load.

(6) A motor vehicle used by a medical practitioner or veterinary surgeon may be fitted above the windscreen with one lamp emitting an intermittently flashing red light in any direction, but such light may only be used by that medical practitioner or veterinary surgeon in the *bona fide* exercise of his or her profession.

(7) A civil defence vehicle defined in paragraph (d) of the definition of “emergency service vehicle” in section 1 of the Act may be fitted with a lamp or lamps emitting an intermittently flashing green light in any direction.

(8) A security service vehicle defined in paragraph (e) of the definition of emergency service vehicle” in section I of the Act may be fitted with an identification lamp of a colour approved by the Minister, but that lamp may only be used in the *bona fide* execution of the duties of the security enterprise concerned.

Use of spot lamp

195. A person may not operate a motor vehicle on a public road if it is fitted with a spot lamp, which can be so adjusted as to enable a beam of light emitted therefrom to be deflected in any direction, but a spot lamp which is adjustable may be -

- (a) fitted and used for official purposes on any ambulance, rescue-, fire-fighting-, police- or traffic control vehicle;
- (b) fitted to a vehicle owned by a medical practitioner or veterinarian and used in the execution of his or her professional duties; or
- (c) fitted to a breakdown vehicle or a vehicle employed in connection with the supply of electricity or other essential public services, but it may be used solely at the scene of an accident, breakdown or for the examination of overhead telephone, telegraph or power lines.

Lamps on pedal cycle

196. (1) A person may not operate a pedal cycle on a public road during the period between sunset and sunrise unless it is fitted in front with a lamp emitting a white light, the

REGULATIONS
Road Traffic and Transport Act 22 of 1999
Road Traffic and Transport Regulations, 2001

intense part of the beam of which must, when the pedal cycle is on a reasonably level road, strike the surface ahead of it at a distance of not less than three metres and not more than 30 metres.

(2) A pedal cycle must be fitted with one or more lamps emitting a red light directly to the rear.

Lamps on animal-drawn vehicles

197. (1) A person may not operate an animal-drawn vehicle on a public road during the period between sunset and sunrise and at any other time when, due to insufficient light or unfavourable weather conditions, persons and vehicles upon the public road would not be clearly discernible at a distance of 150 metres, unless it is fitted in front, on both sides of the body thereof, with lamps emitting a white light forward, and at the rear on both sides of the body thereof; with lamps emitting a red light to the rear.

(2) In the case of a vehicle drawn by animals not controlled by reins, there must be a person leading the animals and carrying a lamp emitting a white light forward at the head of the foremost animal instead of the lamps required in subregulation (1).

Lamps on unspecified vehicles

198. (1) A person may not operate a vehicle, excluding a perambulator, baby cart or child's play vehicle, and which is not elsewhere provided for in regulations 173 to 202, on a public road during the period between sunset and sunrise and at any other time when, due to insufficient light or unfavourable weather conditions, persons and vehicles upon the public road are not clearly discernible at a distance of 150 metres -

- (a) unless it is fitted in front, on both sides of the body thereof, with lamps emitting a white light forward; and
- (b) unless it is fitted at the rear on the extreme right side of the body thereof; with a lamp emitting a red light to the rear.

(2) A lamp contemplated in subregulation (1)(a) must emit a beam of light of sufficient power to illuminate the roadway immediately ahead of such vehicle but must not be of such power or design or so fitted as to cause a dangerous glare to oncoming traffic on a reasonable level road.

Colour of lights

199. (1) Subject to regulation 187, 188, 189, 192 or 194, a person may not operate a motor vehicle on a public road which is fitted with or carries on it a lamp which -

- (a) except in the case of a brake anti-lock warning light to the front of a trailer, emits a light which is not white, amber or yellow in colour towards the front;
- (b) emits a light which is not yellow or amber in colour towards either side of the motor vehicle; or
- (c) except in the case of a direction indicator or reversing lamp complying with these regulations, emits a light which is not red in colour towards the rear.

REGULATIONS
Road Traffic and Transport Act 22 of 1999
Road Traffic and Transport Regulations, 2001

(2) When two or more lamps of the same class emitting light in the same direction are fitted to a vehicle they must emit light of the same colour.

Certain lamps to emit diffused lights

200. Every lamp fitted to a vehicle, other than the headlamps of a motor vehicle, the front lamp of a pedal cycle, spot lamp, inspection lamp or fog lamp, must emit diffused light when in operation on a public road.

Lamps to emit steady light

201. Except where otherwise provided in these regulations, a lamp fitted to or used in connection with any vehicle must emit a steady light when in operation.

Manner in which lamps are to be fitted and maintained

202. (1) The headlamps of a motor vehicle must be fitted at a height of not less than 450 millimetres and not more than one comma four metres above ground level, measured to the centre of the headlamp and not more than 500 millimetres behind the front end of the vehicle.

(2) The headlamps and fog lamps of a motor vehicle must, unless the design of the lamps incorporates some other means of preventing a dangerous glare to oncoming traffic, not be fitted with lenses of clear glass or other like material.

(3) When two or more of the same lamps are fitted to a vehicle they must -

- (a) be placed symmetrically in relation to the longitudinal centre-line of the vehicle; and
- (b) except in the case of side marker lamps and direction indicator lamps, be so placed that any lamp on the side of the vehicle has a corresponding lamp at the same height on the other side of the vehicle.

(4) Every lamp required to be fitted to a vehicle must be securely fixed.

(5) The lens and reflector of every lamp required to be fitted to or used in connection with any vehicle must be maintained in an effective and reasonably clean condition.

(6) No lamp required to be fitted to or displayed in connection with a vehicle may be totally or partially obscured by any fitting or object on the vehicle.

Lamps not prescribed or authorised are prohibited

203. No lamp, other than a lamp prescribed or authorised in terms of these regulations, may at any time be fitted to any vehicle operated on a public road.

White retro-reflectors to be fitted on front of certain vehicles

204. (1) A person may not operate -

- (a) a trailer;
- (b) a person-drawn vehicle; or

REGULATIONS
Road Traffic and Transport Act 22 of 1999
Road Traffic and Transport Regulations, 2001

- (c) an animal-drawn vehicle,

on a public road unless there are fitted, on the front of the vehicle at the same height, two white retro-reflectors, one on each side of the longitudinal centre-line thereof and equidistant therefrom and otherwise complying with these regulations.

- (2) A white retro-reflector -

- (a) may be fitted to a motor vehicle, excluding a trader, in the manner contemplated in subregulation (1) and the retro-reflector must be so placed that the portion of its reflective surface furthest from the longitudinal centre-line of the vehicle is not further than 400 millimetres from the outer edge of the widest portion of the vehicle; and
- (b) if fitted to any vehicle not provided for in paragraph (a), must be so placed that the portion of its reflective surface furthest from the longitudinal centre-line of the vehicle is not further than 150 millimetres from the outer edge of the widest portion of the vehicle.

(3) A person may not operate a pedal cycle on a public road unless it is fitted with a white retro-reflector complying with regulations 207 and 210 on the front of that cycle.

Red retro-reflectors to be fitted on rear of certain vehicles

- 205.** (1) A person may not operate -

- (a) a motor vehicle, excluding a motorcycle without a side-car or motor tricycle with one wheel at the rear;
- (b) a person-drawn vehicle; or
- (c) an animal-drawn vehicle,

on a public road, unless there are fitted on the rear of the vehicle at the same height two red retro-reflectors, one on each side of the longitudinal centre-line thereof and equidistant therefrom and otherwise complying with these regulations, and in the case of a combination of motor vehicles, both the drawing vehicle and the rearmost vehicle must be fitted with such retro-reflectors.

(2) Each retro-reflector referred to in subregulation (1) must be so placed that the portion of its reflective surface furthest from the longitudinal centre-line of the vehicle is not further than 400 millimetres from the outer edge of the widest part of the vehicle.

(3) A person may not operate a motorcycle without a side-car or motor tricycle with one wheel at the rear on a public road unless there is fitted on the rear of the vehicle a red retro-reflector complying with these regulations.

(4) A person may not operate a pedal cycle on a public road unless it is fitted with a red retro-reflector complying with regulations 207 and 210 on the rear of that cycle.

Yellow retro-reflectors to be fitted on sides of certain motor vehicles

REGULATIONS
Road Traffic and Transport Act 22 of 1999
Road Traffic and Transport Regulations, 2001

206. (1) Subject to subregulation (2) a person may not operate a motor vehicle or a combination of motor vehicles on a public road if the overall length of the vehicle or combination of vehicles exceeds seven metres unless each side of that vehicle or each side of every motor vehicle in that combination of vehicles, is fitted with -

- (a) one yellow retro-reflector -
 - (i) within three metres of the front of that vehicle or combination of vehicles;
 - (ii) within one metre of the rear of that vehicle or combination of vehicles; and
 - (iii) in the case of a combination of motor vehicles of which a trailer, other than a semi-trailer, forms a part, within three metres of the front of the trailer; and
- (b) so many additional yellow reflectors as may be necessary to ensure that no two successive yellow reflectors on any side are more than three comma six metres apart, complying with regulations 207 and 210.

(2) Yellow retro-reflectors need not be fitted -

- (a) to a bus or a minibus which is not a school bus, including such a bus or a minibus which forms part of a combination of motor vehicles;
- (b) in the case of a combination of motor vehicles where the drawing vehicle is a motor car, that drawing vehicle.

(3) In the case of a combination of motor vehicles where the drawing vehicle is a motor car, bus or minibus which is not a school bus, the front of that combination is, subject to subregulation (2)(a), deemed to be the front of the vehicle immediately following that drawing vehicle.

General requirements for retro-reflectors

207. (1) Every retro-reflector required to be fitted to a vehicle or load in terms of these regulations -

- (a) may not be lower than 300 millimetres and not higher than one comma five metres from ground level, measured to the centre of the retro-reflector, but if, due to the design of the vehicle, it is impossible to fit retro-reflectors on the sides of the body of the vehicle at the prescribed height, the retro- reflectors must be fitted as near as possible to such height;
- (b) if it is a -
 - (i) white retro-reflector, must be in a vertical position and face squarely to the front;
 - (ii) red retro-reflector, must be in a vertical position and face squarely to the rear; and
 - (iii) yellow retro-reflector, must be in a vertical position and face squarely to the side, but notwithstanding anything to the contrary contained in these regulations, a motor vehicle manufactured, built or imported by a registered

REGULATIONS
Road Traffic and Transport Act 22 of 1999
Road Traffic and Transport Regulations, 2001

manufacturer, builder or importer may have a red retro-reflector fitted at the side towards the rear of that motor vehicle;

- (c) must be clean and in good condition and not be obscured to the extent that it is rendered ineffective; and
- (d) may not be fitted to any movable part of the vehicle, but this paragraph does not apply to a warning sign contemplated in regulation 209(2)(a).

(2) Despite anything to the contrary contained in these regulations, if due to the design of the vehicle it is not possible to fit a retro-reflector in the prescribed position, it may be fitted as close as possible to the prescribed position.

Rear retro-reflectors on vehicle with certain body

208. If it is impossible to fit retro-reflectors on the body of a vehicle in order to comply with the requirements of regulations 205(2) and 207(1)(a), two red retro-reflectors must be fitted to the rear of the vehicle in the manner contemplated in regulation 205(2) as low as possible on the body of that vehicle and two additional red retro-reflectors must be fitted on the rear of that vehicle on the underframe thereof at the height contemplated in regulation 207(1)(a) as far apart as the underframe will permit.

Warning sign on rear of certain motor vehicles (chevrons)

209. (1) For the purposes of this regulation the expression “motor vehicle” does not include a motor vehicle propelled by electrical power derived from overhead wires, motor car, motorcycle, tractor, or any other motor vehicle the gross vehicle mass of which does not exceed 3 500 kg and which is not a trailer, but includes an animal-drawn vehicle.

(2) Subject to subregulation (3), no person shall operate on a public road a motor vehicle unless there is fitted at the rear of such vehicle a warning sign which -

- (a) is a chevron sign which complies with the requirements referred to in standard specification SABS 1329 “Retro-reflective and Fluorescent Warning Signs for Road Vehicles”, Part 4: “Retro-reflective chevron-signs” and Part 5: “Retro-reflective chevron decals”;
 - (b) bears a certification mark;
 - (c) notwithstanding the provisions of paragraph (a), from 1 January 2002 incorporates both retro-reflective red and retro-reflective yellow chevron strips.
- (3) (a) If the design or construction of any motor vehicle does not allow a chevron to be fitted thereto such chevron may be cut into sections to avoid the interference of protrusions, or its edges may be trimmed to permit fitment to the contour of the vehicle or its equipment, but the chevron pattern must be substantially maintained.
- (b) If the design or construction of any motor vehicle does not allow a modified chevron to be fitted thereto as contemplated in paragraph (a), at least 11 retro-reflectors must be fitted to such motor vehicle as shown in diagram A below, and in the case of a trailer the gross vehicle mass of which does not exceed 3 500 kg at least seven retro-reflectors must be fitted to such trailer as illustrated in diagram B below.

REGULATIONS
Road Traffic and Transport Act 22 of 1999
Road Traffic and Transport Regulations, 2001

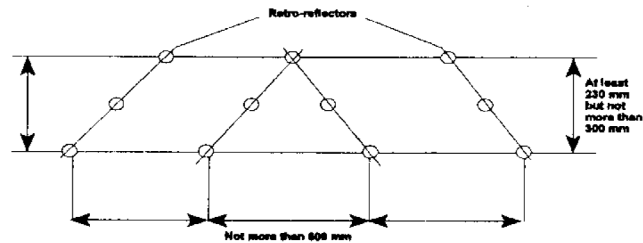

DIAGRAM A

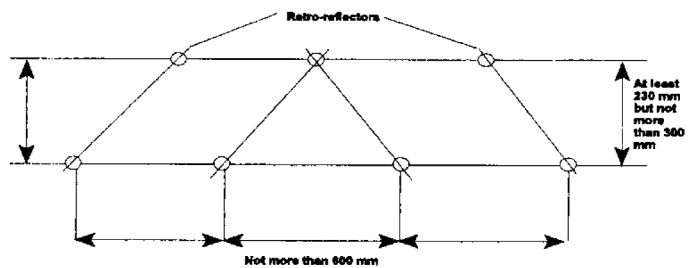

DIAGRAM B

Unlawful use of reflector or reflective material

210. (1) Subject to subregulation (2), a person may not operate any vehicle on a public road while a reflector or reflective material fitted to the vehicle does not reflect a -

- (a) white colour to the front of that vehicle;
- (b) red colour to the rear of that vehicle; and
- (c) yellow colour to the side of that vehicle.

(2) This regulation does not apply to -

- (a) an ambulance, rescue vehicle, police vehicle, a vehicle driven by a traffic officer in the performance of his or her duties and a fire-fighting vehicle;
- (b) a number plate referred to in Chapter 2;
- (c) a warning sign referred to in regulation 209;
- (d) direction indicators referred to in regulation 2 12;
- (e) a sign referred to in regulation 324(2) or 326(2); or
- (f) retro-reflective material as contemplated in regulation 2 11.

(3) Despite subregulation (1), the pedals, pedal arms or spokes of a pedal cycle must, if the cycle is operated on a public road during the period between sunset and sunrise, be fitted with yellow or white reflectors or reflective material.

Side and rear retro-reflective material to be fitted to vehicles (contour markings)

REGULATIONS
Road Traffic and Transport Act 22 of 1999
Road Traffic and Transport Regulations, 2001

211. (1) For the purposes of this regulation “contour markings” means yellow side and rear retro-reflective material that complies with standard specification SABS ECE R104 “Uniform provisions concerning the approval of retro-reflective markings for heavy and long vehicles and their trailers”, but -

- (a) any rear underrun protection device must be fitted along its length with a rear retro-reflective marking strip;
- (b) application for (paragraph 3 of SABS ECE R104) and approval of (paragraph 5 of SABS ECE R104), any retro-reflective marking material is not required under these regulations, but the letter “C” indicating contour or strip marking as referred to in paragraph 5.4.3.1 of SABS ECE R104, and the circle surrounding the letter “E” followed by the distinguishing number of the country which has granted approval as referred to in paragraph 5.4.1 of SABS ECE R104, must be brought onto the retro-reflective marking material; and
- (c) advertising, consisting of retro-reflective logos, distinctive markings or letters or characters may be used if -
 - (i) it complies with the requirements of the said standard specification SABS ECE R104; and
 - (ii) it is used in conjunction with contour markings, excluding marking strips, which indicates the manufacturer concerned.
- (2) a goods vehicle with -

[The word “a” at the beginning of this subregulation should be capitalised.]

- (a) a gross vehicle mass exceeding 10 000 kilograms must, from 1 January 2007, be fitted with contour markings on the side and the rear of such vehicle and the rear contour markings may not be fitted more than 600 millimetres from the lower part of the body of the vehicle; and
- (b) a length of more than six metres, must, from 1 January 2007, be fitted with side and rear contour markings, in accordance with paragraph (a).

(3) A trailer must, from 1 January 2007, be fitted with side and the rear contour markings, in accordance with subregulation (2)(a).

[The word “the” before the word “rear” is superfluous.]

(4) A bus must, from 1 January 2007, be fitted with side and rear contour markings, in accordance with subregulation (2)(a).

[regulation 211 substituted by GN 188/2006]

Motor vehicle to be equipped with direction indicators

212. (1) A person may not operate any motor vehicle, excluding a tractor or a trailer, on a public road unless it is equipped on both sides with direction indicators of one of the types referred to in regulation 213 or 214 and which complies with the provisions thereof, but where a motor vehicle forms part of a combination of motor vehicles and a direction indicator with

REGULATIONS
Road Traffic and Transport Act 22 of 1999
Road Traffic and Transport Regulations, 2001

which the motor vehicle is required to be equipped is obscured by any trailer forming part of that combination, the trailer is, subject to regulation 216 deemed to be part of that motor vehicle.

- (2) Subregulation (1) does not apply to -
 - (a) a motorcycle which, according to its registration certificate, was registered for the first time before 1 July 1976; or
 - (b) any motor vehicle which, according to its registration certificate, is older than 40 years.

Direction indicators of flashing type

213. Direction indicators of the flashing type must comply with the following requirements:

- (a) Each indicator must incorporate a lamp or lamps;
- (b) when in use the lamp must show an intermittently-flashing light of such intensity that it is clearly visible in normal daylight at a distance of not less than 30 metres to a person of normal eyesight;
- (c) the indicators must be equidistant from the longitudinal centre-line of the motor vehicle and as near as possible to, but not more than 500 millimetres from, the outer edge of the front or rear of the motor vehicle;
- (d) subject to paragraph (e), the indicators must be so mounted that they are visible from the -
 - (i) rear, anywhere within an angle of 15 degrees inside and 45 degrees outside; and
 - (ii) front, anywhere within an angle of 45 degrees outside, of a line which is parallel to the longitudinal centre-line of the vehicle and which passes through the centre of the illuminated area of the indicator;
- (e) where it is not possible to comply with paragraph (d) in the case of a single indicator on any one side, one indicator must be mounted towards the front and one towards the rear so that one must be visible from the front and the other from the rear of the vehicle to which it is fitted within the limits prescribed by that paragraph;
- (f) where any indicator is combined with or mounted within 150 millimetres of any lamp, the intensity of the light emitted from the indicator must be greater than that from the lamp; and
- (g) the indicator lamps when in use must emit white, yellow or amber light to the front and yellow, amber or red light to the rear and any one indicator may emit light towards the front and the rear simultaneously or emit light only to the front or only to the rear according to its position on the vehicle.

Direction indicator of illuminated window type

REGULATIONS
Road Traffic and Transport Act 22 of 1999
Road Traffic and Transport Regulations, 2001

214. Direction indicators of the illuminated window type must comply with the following requirements:

- (a) Each indicator must incorporate a lamp which, when in operation, must emit a red, yellow or amber light to the rear and of such intensity that it is clearly visible in normal daylight at a distance of not less than 30 metres to a person of normal eyesight;
- (b) the indicator must be at least 150 millimetres long, 25 millimetres wide and arrow-shaped; and
- (c) the indicator must be fitted to the rear of the vehicle.

Combination of different types of direction indicators

215. Despite anything contained in these regulations, the fitting of two direction indicators of one of the types referred to in regulations 213 and 214 on the front half of a vehicle and two direction indicators of another type referred to in the said regulations on the rear half of that vehicle is permitted.

Direction indicators on motor vehicles with an overall length in excess of seven comma six metres

216. (1) A person may not operate any motor vehicle or combination of motor vehicles of an overall length in excess of seven comma six metres on a public road unless it is equipped on both sides on the front half and the rear half with direction indicators of any of the two types referred to in regulation 213 and 214 that complies with the provisions thereof.

(2) Illuminated window type direction indicators on the rear half of a motor vehicle or combination of motor vehicles referred to in subregulation (1), must be -

- (a) within 600 millimetres of the rear end of the motor vehicle; or
- (b) in the case of a combination of motor vehicles, within 600 millimetres of the rear end of the last vehicle of that combination.

(3) Until 1 April 2003, this regulation does not apply in respect of a tractor or a combination of motor vehicles of which the drawing vehicle is a tractor.

General requirements for direction indicators

217. (1) Direction indicators must be fitted at a height of not less than 450 millimetres and not more than two comma one metres above ground level and must be unobstructed when in use, but -

- (a) in respect of any direction indicator contemplated in regulation 213 the minimum height requirements does not apply; and

[The verb “does” should be “do” to accord with the subject “requirements”.]

- (b) a direction indicator contemplated in regulation 213 fitted on the side of a motor vehicle may not be more than two comma three metres above ground level.

REGULATIONS
Road Traffic and Transport Act 22 of 1999
Road Traffic and Transport Regulations, 2001

(2) If lamps are incorporated in direction indicators, the lamps showing to the front must be located on the same level and the lamps showing to the rear must be located on the same level.

(3) Unless the direction indicators are so fitted that they are directly or by reflection visible to the driver of the vehicle to which they are fitted when he or she is in the driving position, a device must be provided whereby he or she must be given a visible or audible warning when the indicators are in operation.

(4) The direction indicators must be so fitted that the indicators on one side can be operated separately from those on the other side.

(5) (a) A person may not operate a motor vehicle on a public road unless it is fitted with a separate switch to operate all the direction indicators simultaneously.

(b) Paragraph (a) does not apply to -

(i) a tractor;

(ii) a trailer;

(iii) a motorcycle; or

(iv) any motor vehicle which according to its registration certificate, was registered for the first time before 1 January 1986.

(6) (a) The driver of a motor vehicle fitted with a separate switch to operate all the direction indicators simultaneously, must put into operation simultaneously all the direction indicators fitted to that vehicle, when the vehicle is -

(i) stationary in a hazardous position; or

(ii) in motion in an emergency situation.

(b) The driver of a motor vehicle may not put into operation all the direction indicators fitted to the motor vehicle simultaneously in a circumstance other than those referred to in paragraph (a).

(7) If more than one direction indicator is fitted to indicate any one turning movement all the indicators must be interconnected so as to operate simultaneously.

(8) Direction indicators must be maintained in good working order.

(9) All lamps of direction indicators must, when in use, emit diffused light.

(10) A motor vehicle, which is being towed by a breakdown vehicle, must be fitted with a separate temporary set of direction indicators that are coordinated with the working of the direction indicators of the breakdown vehicle while the motor vehicle is so towed.

Prohibition against use of direction indicator not complying with regulations

REGULATIONS
Road Traffic and Transport Act 22 of 1999
Road Traffic and Transport Regulations, 2001

218. The driver of a motor vehicle on a public road shall not make use of any direction indicator not complying with these regulations.

Steering mechanism

- 219.** (1) A person may not operate a motor vehicle on a public road -
- (a) unless all parts of the steering mechanism are maintained in a condition which enables the vehicle to be steered safely and efficiently;
 - (b) unless, in addition to the requirements of paragraph (a), all parts of the steering mechanism are so adjusted that, unless otherwise designed by the manufacturer, the amount of movement which the steering wheel makes before the steering mechanism becomes effective in changing the direction of the steerable wheels from a position where such wheels are parallel to the longitudinal centre-line of the vehicle, to the right or left is no more than 12,5 per cent of the outside circumference of the steering wheel, (that is to say, 45 degrees);
 - (c) which is fitted with an anti-theft device which enables the steering wheel to be disengaged or disconnected from the steering mechanism of the vehicle.
- (2) (a) Subject to paragraph (b), a person may not operate a motor vehicle on a public road first registered on or after 1 January 2003, the steering wheel of which is on the left hand side.
- (b) Paragraph (a) does not apply in respect of a vehicle manufactured, built or imported by a registered manufacturer, builder or importer for the purpose of export or for the purpose of testing, assessment or development, if the vehicle is operated on a public road in terms of a special permit.
- (3) A person may not operate a motorcycle on a public road -
- (a) unless the handlebars are symmetrically placed in relation to the longitudinal centre-line of the cycle;
 - (b) unless the distance between the outside edges of the handlebars is at least 600 millimetres in respect of a motorcycle with an engine with a cylinder capacity of 200 cubic centimetres or more and at least 500 millimetres in respect of all other motorcycles; or
 - (c) of which the outer ends of the handgrips on the handlebars are -
 - (i) higher than 500 millimetres above the seat height; or
 - (ii) lower than the seat height,and more than 800 millimetres apart.

Sounding devices

220. (1) Subject to section 75(3) and 77 of the Act, a person may not operate on a public road a -

REGULATIONS
Road Traffic and Transport Act 22 of 1999
Road Traffic and Transport Regulations, 2001

[The singular word “section” should be the plural word “sections”.]

- (a) self-propelled motor vehicle, unless it is equipped with an efficient sounding device which is in good working order and, when used, capable of emitting a sound which, under normal conditions, is clearly audible by a person of normal hearing from a distance of at least 90 metres;
- (b) pedal cycle, unless it is equipped with an efficient sounding device which is in good working order and, when used, capable of giving adequate warning of its approach;
- (c) vehicle to which a siren is fitted; or
- (d) vehicle to which a device is fitted which emits a sound of which the tone of pitch varies, but paragraphs (c) and (d) do not apply to a motor vehicle which is fitted with an anti-theft device which incorporates a siren, an emergency service vehicle or a vehicle driven by a traffic officer in the carrying out of his or her duties.

(2) The device which may be fitted to a vehicle referred to in sections 75(3)(b) and 77(b) of the Act must comply with the specifications determined by the Minister by notice in the *Gazette*.

Glass of windscreen, window and partitions

221. (1) A person may not operate, on a public road, any motor vehicle that has a windscreen, window or partition made of transparent material unless -

- (a) the transparent material affords the driver sufficient visibility for safe driving of the motor vehicle;
- (b) in the case of a windscreen, other than a windscreen fitted to a motorcycle or motor tricycle, the transparent material -
 - (i) is glass; and
 - (ii) in respect of a motor vehicle which, according to its registration certificate, was registered for the first time after the year 1958, complies with paragraph (a) even when shattered; and
- (c) in respect of a motor vehicle which, according to its registration certificate, was registered for the first time after the year 1958, the transparent material is safety glass and every pane thereof is permanently marked with the name or trade mark of the manufacturer thereof or the trade name of the glass and is clearly identifiable as safety glass by a permanent mark describing it as such.

(2) Notwithstanding paragraphs (b) and (c) of subregulation (1), the transparent material -

- (a) of which -
 - (i) a window in the roof of a motor vehicle;
 - (ii) a window or partition of a bus or a minibus; or

REGULATIONS
Road Traffic and Transport Act 22 of 1999
Road Traffic and Transport Regulations, 2001

- (iii) a window or partition of a semi-trailer designed or adapted for the conveyance of passengers, is made, may consist of ultrahigh impact acrylic or polycarbonate plastic material where each pane thereof is permanently marked with the name or trademark of the manufacturer thereof or the trade name of the material, and the material is clearly identifiable as ultrahigh impact acrylic or polycarbonate plastic material by a permanent mark describing it as such;
- (b) of which a window or partition of a removable or collapsible hood or canopy of a motor vehicle is made, may consist of a flexible plastic material; and
- (c) of which a window or partition of a trailer not designed or adapted for the conveyance of passengers is made, may, in the case where the trailer according to its registration certificate -
 - (i) was registered for the first time before 1 January 1987, consist of acrylic or polycarbonate plastic material or of glass; or
 - (ii) was registered for the first time on or after 1 January 1987, consist of acrylic or polycarbonate plastic material.
- (3) A person may not operate a motor vehicle on a public road, unless -
 - (a) the visible light transmittance through -
 - (i) the windscreen is at least 70 per cent; and
 - (ii) any other window is at least 35 per cent,

when measured in accordance with paragraph 6.3 of the Standard Specifications SABS 1191:1978 "Safety Glass for Windows" published by the South African Government Notice No. 463 of 9 July 1982; and
 - (b) any film or tinting material applied to any windscreen, window or partition is free from bubbles, tears or scratches.
- (4) A person may not operate on a public road any motor vehicle if, after 1 January 2002, any film or material with a texture surface or any fixture or attachment, excluding tinting material is positioned over or applied to a windscreen or window of the motor vehicle in such a manner that its presence reduces visibility through that windscreen or window in any direction.
- (5) The provision of subregulation (3)(a)(ii) does not apply to an ambulance or a hearse.

Windscreen wiper

222. A person may not operate a motor vehicle on a public road with a wind- screen which is not fitted with at least one windscreen wiper which must be capable of operation by other than manual means and must, when in operation, wipe the outside of the windscreen directly in front of the driver continuously, evenly and adequately, but this regulation does not apply to a motorcycle without a fixed hood.

Unobstructed driver's view

REGULATIONS
Road Traffic and Transport Act 22 of 1999
Road Traffic and Transport Regulations, 2001

- 223.** (1) A person may not operate a motor vehicle on a public road -
- (a) which is not so constructed and maintained as to afford the driver thereof a full and clear view of the roadway ahead and to his or her right and left when the vehicle is in use;
 - (b) which is not fitted with a rear-view mirror or mirrors enabling the driver of that vehicle when he or she is in the driving position to see in clear weather a clear reflection of traffic to the rear, but this paragraph does not apply to a tractor;
 - (c) which is a motor car, bus, minibus or goods vehicle, the gross vehicle mass of which does not exceed 3 500 kilograms and which, according to its registration certificate, was registered for the first time on or after 1 January 1987, unless it is fitted with an exterior rear-view mirror on the driver's side and an interior rear-view mirror, but if the interior rear-view mirror does not enable the driver, when he or she is in the driving position, to see in clear weather, a clear reflection of traffic to the rear, an additional exterior rear-view mirror must be fitted on the side opposite to the driver's seat and in such a case it is not necessary to fit an interior rear-view mirror;
 - (d) which is a bus, minibus or goods vehicle, with a gross vehicle mass which exceeds 3 500 kilograms and which, according to its registration certificate, was registered for the first time on or after 1 January 1987, unless it is fitted with another exterior rear-view mirror on the driver's side and another exterior rear-view mirror on the side opposite to the driver's seat; or
 - (e) which is a motorcycle, unless it is fitted with a rear-view mirror on both sides of its handlebars.
- (2) Every rear-view mirror of a motor vehicle -
- (a) which -
 - (i) is a motor car, bus, minibus or goods vehicle with a gross vehicle mass which does not exceed 3 500 kilograms and which, according to its registration certificate, was registered for the first time on or after 1 January 1976; or
 - (ii) is a bus, minibus or goods vehicle, with a gross vehicle mass which exceeds 3 500 kilograms and which, according to its registration certificate, was registered for the first time during the period 1 January 1976 to 31 December 1986,

must be either flat or spherically convex and have an average radius of curvature of not less than one comma two metres; or
 - (b) contemplated in subregulation (1)(d) must be either flat or spherically convex and have an average radius or curvature of not less than one comma eight metres.

Fuel tank, electrical wiring and battery

- 224.** A person may not operate a motor vehicle on a public road -

REGULATIONS
Road Traffic and Transport Act 22 of 1999
Road Traffic and Transport Regulations, 2001

- (a) if its fuel tank, carburettor, fuel receptacle or fuel pipe is defective or so exposed that it constitutes a source of danger;
- (b) if the filling aperture of the fuel tank is not fitted with an effective cap; or
- (c) unless the electrical wiring and battery are properly installed, insulated and maintained so that it does not constitute a source of danger.

Engine of motor vehicle to be covered

225. A person may not operate a motor vehicle on a public road, other than a motorcycle or other cycle, unless the engine thereof is so covered as not to be a source of danger.

Compulsory wearing of protective helmet in respect of motorcycle and pedal cycle

226. (1) A person may not drive or be a passenger on a motorcycle, or be a passenger in the side-car attached to a motorcycle, on a public road unless he or she is wearing a protective helmet -

- (a) which is specially designed for use in connection with that cycle; and
- (b) which fits him or her properly and of which the chin strap is properly fastened under his or her chin.

(2) The driver of a motorcycle shall ensure that any passenger in or on that cycle, who is younger than 14 years, complies with subregulation (1).

(3) After a date determined by the Minister by notice in the *Gazette*, a person may not drive or be a passenger on a pedal cycle, on a public road unless he or she is wearing a protective helmet -

- (a) which is specially designed for use in connection with that pedal cycle; and
- (b) which fits him or her properly and of which the chin strap is properly fastened under his or her chin, and the driver of that pedal cycle must, subject to regulation 346(5), ensure that his or her passenger complies with this subregulation.

Manner in which side-car is to be attached to motorcycle

227. From a date determined by the Minister in the *Gazette*, a person may not operate a motorcycle with a side-car, on a public road unless the side-car is attached to the left side of the motorcycle in such a manner that the centre-line of the axle of the side-car is within the wheelbase of the motorcycle, and a side-car may not be attached to a motorcycle that has an engine with a cylinder capacity of less than 50 cubic centimetres.

Exhaust silencers and exhaust pipes

228. A person may not operate a motor vehicle on a public road -

- (a) unless an efficient exhaust silencer or muffling device is affixed thereto in such a manner that the exhaust gas from the engine is projected through the silencer or

REGULATIONS
Road Traffic and Transport Act 22 of 1999
Road Traffic and Transport Regulations, 2001

muffling device, which must be so constructed as to reduce and muffle the sound produced by that exhaust in an effective manner;

- (b) if any mechanism or device is attached thereto enabling the exhaust gas from the engine of that motor vehicle to be projected otherwise than through the silencer or muffling device referred to in paragraph (a);
- (c) if the exhaust gas or smoke from the engine is so dense as to cause a nuisance to, or obstruct the vision of other road users;
- (d) if the exhaust pipe or silencer thereof is in such a position that oil or other flammable liquid or material can drip or fall onto it, or is not in efficient working order, or is so placed and maintained that exhaust gas or smoke leaks into the driver's cab or passenger compartment of the vehicle; and
- (e) which, when tested, exceeds the limits prescribed in Code of Practise SABS 0181: 1981 "The measurement of noise emitted by road vehicles when stationary" published by the South African Government Notice No. 463 of 9 July 1982.

Entrances and exits

229. (1) A person may not operate a motor vehicle on a public road with a fixed hood and a tare in excess of 570 kilograms unless the motor vehicle has at least -

- (a) a convenient means of entrance and exit on both the left side and the right side; or
- (b) such means of entrance and exit on either the left side or the right side and a ready means of escape on the side opposite to such means of entrance and exit or at the rear, for the occupants thereof, and where the vehicle is so operated while conveying passengers in a separate compartment which does not -
 - (i) comply with paragraph (a) or (b); or
 - (ii) afford such passengers unobstructed access to the driving compartment, that vehicle must have at least a convenient means of entrance and exit at the rear for the passengers.

(2) A means of entrance and exit and a means of escape referred to in subregulation (1), must be equipped with a door or other effective barrier, but a means of entrance and exit at the rear of a motor vehicle need not be so equipped.

(3) A door or barrier contemplated in subregulation (2) or a door or other barrier with which a means of entrance and exit at the rear of a motor vehicle is equipped, must be -

- (a) capable of being opened and closed from both the outside and the inside; and
- (b) closed and clear of any obstruction when the vehicle is in motion,

but paragraph (a) does not apply to a means of escape which has a barrier which is capable of being opened by being knocked out.

(4) This regulation does not apply to a bus, minibus or the separate compartment of a motor vehicle in which prisoners are conveyed.

REGULATIONS
Road Traffic and Transport Act 22 of 1999
Road Traffic and Transport Regulations, 2001

Motor vehicle to be capable of travelling in reverse and forwards

230. A person may not operate a motor vehicle, other than a motorcycle, on a public road if the tare thereof exceeds 570 kilograms, unless it can be driven in reverse and forwards.

Tyres

231. A person may not operate on a public road -

- (a) a motor vehicle, other than a tractor or trailer, which is equipped with a metal tyre;
- (b) a tractor or trailer, other than an animal-drawn vehicle, which is equipped with a metal tyre less than 130 millimetres in width;
- (c) an animal-drawn vehicle which is equipped with a metal tyre less than 40 millimetres in width;
- (d) a vehicle which is equipped with a metal tyre unless the tyre is so fitted and adjusted that the whole of the tread width of the tyre will at all times be in direct contact with the surface of the road;
- (e) a vehicle which is equipped with a tyre which is in such a state of disrepair or in such a condition that it may cause or is likely to cause damage to the road surface or may be or is likely to be a danger;
- (f) a motor vehicle which is equipped with a pneumatic tyre of which the rubber covering is so worn or damaged that the fabric or cord used in the construction thereof is exposed;
- (g) a motor vehicle of which a tyre is so constructed and fitted that the metal part of the wheel to which the tyre is fitted may come into contact with the road surface;
- (h) a motorcycle which is equipped with a retreaded tyre;
- (i) a motor vehicle which is equipped with a regrooved tyre having a bead diameter of 430 millimetres or less;
- (j) a motor vehicle, excluding a motorcycle with an engine that has a cylinder capacity not exceeding 125 cubic centimetres or a trailer drawn by a tractor at a speed not exceeding 35 km per hour, which is fitted with a pneumatic tyre, unless the tread of the tyre displays throughout its breadth and around its entire circumference a pattern, the tread of which is clearly visible and is at least one millimetre in depth;
- (k) a motorcycle with an engine that has a cylinder capacity not exceeding 50 cubic centimetres, which is fitted with a pneumatic tyre which does not at any position on the tread thereof have a visible tread pattern over at least 80 per cent of the full width of the tread;
- (l) a motor vehicle which is equipped with a pneumatic tyre which has a break in its fabric or which has a cut, measured in any direction on the outside of the tyre and of such depth that it reaches the cords used in the construction of such tyre, in

REGULATIONS
Road Traffic and Transport Act 22 of 1999
Road Traffic and Transport Regulations, 2001

excess of 25 millimetres or 10 per cent of the maximum width of the tyre, whichever is the greater; or

- (m) a motor vehicle which is equipped with a pneumatic tyre which has a lump or bulge caused by the separation of or a partial break in its structure.

Seatbelts

232. (1) For the purpose of this regulation -

- (a) an adult is a person over the age of 14 years or taller than one comma five metres; and
- (b) a child is a person between the age of three years and 14 years, except where that person is taller than one comma five metres.

(2) Any reference to a seat belt in these regulations must be construed as a reference to a safety belt.

- (3) (a) Motor vehicles which are required to be fitted with seatbelts in terms of any compulsory specification with regard to the manufacturing of motor vehicles must be fitted with seatbelts that comply with those specifications.
- (b) In addition to the requirements of paragraph (a), a person may not operate a minibus with a gross vehicle mass which exceeds 2 500 kilograms, unless seatbelts are fitted to the space on the front seat occupied by the driver, and if the front seat has seating accommodation for passengers, unless seatbelts are fitted for the driver and at least one passenger.
- (c) A person may not operate a motor vehicle on a public road unless the seatbelts fitted to the motor vehicle are in good working order.
- (d) Seatbelts fitted to a motor vehicle may only be removed for repair or replacement purposes and the motor vehicle may not be used on a public road while the seatbelts are being repaired or replaced.

(4) No adult may occupy a seat in a motor vehicle operated on a public road which is fitted with a seatbelt unless that adult wears the seatbelt, but this regulation does not apply while reversing or moving in or out of a parking bay or area.

(5) No adult may occupy a seat on a row of seats in a motor vehicle operated on a public road which is not fitted with a seatbelt, unless all other seats on that row which are fitted with seatbelts, are already occupied.

(6) The driver of a motor vehicle being operated on a public road must ensure that -

- (a) every adult being conveyed in that motor vehicle complies with subregulations (4) and (5); and
- (b) every child seated on a seat of that motor vehicle -
 - (i) uses an appropriate child restraint, if available in that motor vehicle; or

REGULATIONS
Road Traffic and Transport Act 22 of 1999
Road Traffic and Transport Regulations, 2001

- (ii) wears, in the instance where no child restraint is available, a seatbelt if an unoccupied seat fitted with a seatbelt is available.

[subregulation (6) substituted by GN 205/2004]

(7) If no seat equipped with a seatbelt is available in a motor vehicle, the driver of the motor vehicle operated on a public road must ensure that a child, if that motor vehicle is equipped with a rear seat, is seated on the rear seat.

(8) A seatbelt fixed to a motor vehicle must be -

- (a) installed in accordance with SANS 10168:2002, Ed. 1.01: “The installation of restraining devices, safety belts, in motor vehicles incorporating part of EEC Directive 77/541 ‘Safety belts and restraint systems of motor vehicles’, and the amending EEC Directives 81/576 and 82/319, with modifications”; and
- (b) comply with South African National Standard 1080:2002, Ed. 1.01: “Restraining devices, safety belts, for occupants of adult build in motor vehicles”.

[subregulation (8) substituted by GN 156/2015]

(9) The Minister may exempt a person from this regulation on such medical grounds and under such conditions, as he or she may consider expedient.

(10) An exemption to wear a seatbelt in another country is deemed to be an exemption in terms of subregulation (9) for the period of validity thereof.

Emergency warning signs (Triangle)

233. (1) For the purposes of this regulation -

- (a) “motor vehicle” does not include an emergency service vehicle or a motorcycle; and
- (b) “reflective material” means reflective material; which is capable of reflecting light under all circumstances;

[subregulation (1) substituted by GN 188/2006]

(2) The expression “emergency warning sign” means -

- (a) in the case of a motor vehicle, with a gross vehicle mass of 3 800 kilograms or less, a double-sided sign having the shape, design, minimum dimension and colours illustrated below, and of which the red portion on each side -
- (i) consists of red reflective material; or
- (ii) is painted red and have retro-reflectors in each corner; or

[The verb “have” should be “has” to be grammatically correct.]

REGULATIONS
Road Traffic and Transport Act 22 of 1999
Road Traffic and Transport Regulations, 2001

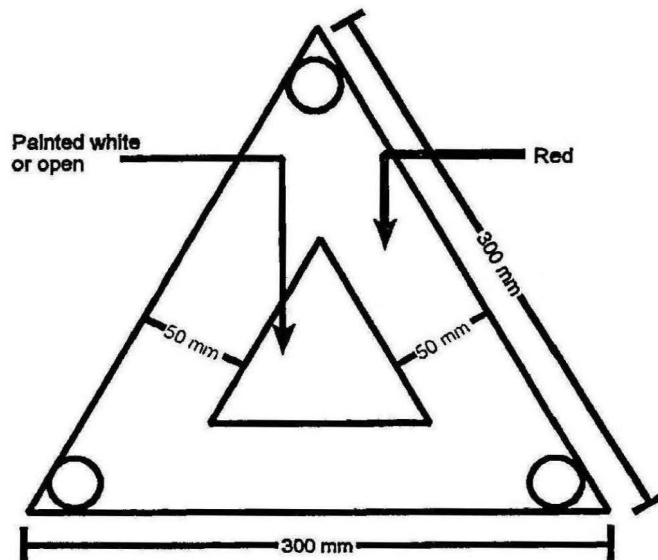

- (b) in the case of any other motor vehicle, a sign that complies with the standard specification SABS 1329 “Retro-Reflective and Fluorescent Warning Signs for Road Vehicles”, Part 1: 1987 “Triangles”, and bears the certification mark, but in the case of a combination of motor vehicles, the emergency warning sign for every motor vehicle of such combination may be carried on the drawing vehicle, and in the case of a combination of three motor vehicles, at least two emergency warning signs must be carried on the vehicle.

[subregulation (2) substituted by GN 188/2006]

(3) Where a motor vehicle is for any reason stationary on the roadway of a public road, the driver of that vehicle must display or cause to be displayed at least one emergency warning sign in the manner contemplated in subregulation (5).

(4) A person may not, without lawful cause, remove or tamper with any emergency warning sign which is being displayed in accordance with this regulation.

(5) At least one emergency warning sign must be displayed in the following manner:

(a) The sign must be placed not less than 45 metres from the motor vehicle along the roadway of the public road concerned in the direction from which traffic will approach that motor vehicle when travelling on the side of the roadway closest to that motor vehicle;

(b) the sign must be placed approximately as far from the edge of the roadway as the transverse centre of that motor vehicle is from the edge of the roadway; and

(c) the reflective side of the sign must face in the direction from which any traffic will approach.

(6) Subregulation (3) does not apply where a motor vehicle is stationary -

(a) in a place where a road traffic sign authorises the loading or unloading of a vehicle;

REGULATIONS
Road Traffic and Transport Act 22 of 1999
Road Traffic and Transport Regulations, 2001

- (b) in compliance with any direction conveyed by a road traffic sign or given by a traffic officer;
- (c) on account of other traffic on the public road concerned and while the driver occupies the driver's seat of that motor vehicle; or
- (d) in the usual course of events accompanying the carrying out of a State or local authority function.

Speedometers

234. (1) A person may not operate a motor vehicle on a public road which is designed for or capable of reaching a speed of 60 kilometres per hour or more on a reasonably level road, unless the motor vehicle is equipped with a speedometer which is in a good working order.

- (2) Subregulation (1) does not apply to -
 - (a) a trailer; or
 - (b) a new motor vehicle while -
 - (i) being delivered by a motor transport contractor in the course of his or her business;
 - (ii) being delivered by a manufacturer to a motor dealer; or
 - (iii) being used by a motor dealer in the course of his or her business for the purpose of selling, exchanging or repairing of the motor vehicle or building a permanent structure thereon.

Motor vehicles operated on public road to comply with compulsory vehicle specifications

235. (1) A motorcar, minibus, bus or goods vehicle fitted with at least four wheels, or a trailer, operated on a public road must comply with the appropriate requirements as specified in the Government Notices issued in terms of section 22 of the Standards Act, 1993 (Act No. 29 of 1993) and listed in Annex A to The Code of Practice SABS 047: 1995 "The testing of motor vehicles for roadworthiness", as published in the South African Government Notice No. R.298 of 22 February 1991.

(2) A person may not operate a motor vehicle on a public road unless all the equipment required to be on the motor vehicle in terms of subregulation (1) is fitted to that motor vehicle and in good working order.

[Regulation 235 is not yet in force.]

Wheel flaps

236. (1) After 1 July 2002 a person may not operate a trailer with a gross vehicle mass exceeding 3 500 kilograms, or a bus or goods vehicle with a gross vehicle mass exceeding 7 500 kilograms, on a public road unless it is fitted with wheel flaps -

REGULATIONS
Road Traffic and Transport Act 22 of 1999
Road Traffic and Transport Regulations, 2001

- (a) which are properly maintained and approved by the vehicle manufacturer; or
- (b) which comply with standard specification SABS 1496 "Wheel flaps fitted to motor vehicles".
- (2) Subregulation (1) does not apply to -
 - (a) a chassis or a cab and chassis which is being driven to a manufacturer, builder or motor dealer;
 - (b) a truck-tractor; or
 - (c) a vehicle which complies with the standard specification SABS 1496 "Wheel flaps fitted to motor vehicles", due to its design.

Rear underrun protection device

237. Subject to such exemptions as may be provided for under any specification as referred to in regulation 235, a rear underrun protection device which complies with the standard specification SABS I 055 "Rear underrun protection device" must be fitted to -

- (a) a trailer with a gross vehicle mass which exceeds 3 500 kilograms, first registered on or after 1 January 1988;
- (b) any other goods vehicle with a gross vehicle mass which exceeds 12 000 kilograms, first registered on or after 1 January 1988,

but after 1 January 2002, such rear underrun protection device must be fitted to any trailer with a gross vehicle mass which exceeds 3 500 kilograms and any goods vehicle with a gross vehicle mass which exceeds 12 000 kilograms.

Axle or axle unit to be fitted to semi-trailer

238. A semi-trailer first registered on or after 1 July 2002, may be fitted with only one axle unit, which axle unit must be fitted with suspension of one type only namely either air suspension, steel suspension or rubber suspension.

Certain vehicles exempt from certain regulations of this Part

239. (1) Except for a breakdown vehicle, any vehicle, which is a drilling machine, a mobile crane, a fork lift, a straddle truck, a road making machine, an earthmoving machine, an excavation machine, a construction machine or a loading machine, is exempt from this Part, except for -

- (a) regulation 165 (Brakes on motor vehicles other than motorcycle or trailer);
- (b) regulation 167 (Brakes on trailers);
- (c) regulation 169 (Brakes on unspecified vehicles);
- (d) regulation 170 (Specification for brakes);
- (e) regulation 171 (Braking performance of service, emergency and parking brakes);

REGULATIONS
Road Traffic and Transport Act 22 of 1999
Road Traffic and Transport Regulations, 2001

- (f) regulation 172 (Condition and operation of brakes);
- (g) regulation 219 (Steering mechanism);
- (h) regulation 221 (Glass of windscreen, window and partitions);
- (i) regulation 222 (Windscreen wiper);
- (j) regulation 223 (Unobstructed driver's view);
- (k) regulation 224 (Fuel tank, electrical wiring and battery);
- (l) regulation 228 (Exhaust silencers and exhaust pipes);
- (m) regulation 229 (Entrances and exits);
- (n) regulation 230 (Motor vehicle to be capable of travelling in reverse and forwards);
- (o) regulation 231 (Tyres).

(2) Any vehicle, including a tractor, which is not a goods vehicle and which is used solely for *bona fide* agricultural, horticultural, viticultural or pastoral pursuits and when operated on a public road, is excluded from this Part, except for -

- (a) regulation 165 (Brakes on motor vehicles other than motorcycle or trailer);
- (b) regulation 167 (Brakes on trailers);
- (c) regulation 169 (Brakes on unspecified vehicles);
- (d) regulation 170 (Specifications for brakes);
- (e) regulation I 71 (Braking performance of service emergency and parking brakes);
- (f) regulation 172 (Condition and operation of brakes);
- (g) regulation 219 (Steering mechanism);
- (h) regulation 221 (Glass of windscreen, window and partitions);
- (i) regulation 222 (Windscreen wiper);
- (j) regulation 223 (Unobstructed driver's view);
- (k) regulation 224 (Fuel tank, electrical wiring and battery);
- (l) regulation 228 (Exhaust silencers and exhaust pipes);
- (m) regulation 229 (Entrances and exits);
- (n) regulation 231 (Tyres).

REGULATIONS
Road Traffic and Transport Act 22 of 1999
Road Traffic and Transport Regulations, 2001

(3) The exemptions provided for in subregulations (1) and (2) are subject to the following conditions:

- (a) Those vehicles may not be operated on the roadway of a public road during the period between sunset and sunrise and at any other time when, due to insufficient light or unfavourable weather conditions, persons and vehicle upon the public road are not clearly discernible at a distance of 150 metres;
- (b) the driver of any such vehicle on the roadway of a public road must stop such vehicle, and where possible, drive it off the roadway if necessary in order to allow other vehicular traffic to pass;
- (c) those vehicles, other than a mobile crane which is operated for the purpose of removing any hazard or obstruction on a freeway, may not be operated on a freeway.

(4) Any vehicle owned by the Ministry of Defence and which is not designed or adapted for the carriage of goods or passengers are excluded from the provisions of these regulations relating to the construction or equipment of vehicles, except regulation 231.

PART 4
DIMENSIONS OF VEHICLES

Overall length of vehicle

240. A person may not operate on a public road -

- (a) a trailer which is coupled to a drawing vehicle in such a manner that the trailer and the drawing vehicle cannot swivel in a horizontal plane at the coupling, if the overall length including any drawbar or coupling exceeds one comma eight metres;
- (b) a trailer with one axle or one axle unit, other than a semi-trailer -
 - (i) with a gross vehicle mass exceeding 12 000 kilograms, if the overall length of the trailer, excluding any drawbar or coupling, exceeds 11,3 metres; or
 - (ii) with a gross vehicle mass which does not exceed 12 000 kilograms, if the overall length of the trailer, excluding any drawbar or coupling, exceeds eight metres;
- (c) an articulated motor vehicle or any other combination of motor vehicles consisting of a drawing vehicle and a semi-trailer, if the overall length of the motor vehicle or combination of motor vehicles, including any drawbar or coupling, exceeds 18,5 metres;
- (d) a bus train, if the overall length thereof exceeds 20 metres;
- (e) a trailer not referred to in paragraph (b), excluding a semi-trailer, with a gross vehicle mass exceeding 12 000 kilograms, if the overall length of the trailer, excluding any drawbar or coupling, exceeds 12,5 metres;
- (f) any other vehicle, excluding a semi-trailer, if the overall length, including any drawbar or coupling, exceeds 12,5 metres; or

REGULATIONS
Road Traffic and Transport Act 22 of 1999
Road Traffic and Transport Regulations, 2001

- (g) any combination of motor vehicles, if the overall length thereof, including any drawbar or coupling exceeds 22 metres, but this paragraph does not apply to a breakdown vehicle while towing any other motor vehicle,

[paragraph (g) substituted by GN 205/2004]

but, equipment fitted to the front of a vehicle referred to in paragraph (c), (f) or (g), other than the bumper fitted by the manufacturer of the motor vehicle concerned, to protect its bodywork and lighting equipment and which increases the overall length of that vehicle by not more than 300mm may not be taken into account for the purposes of calculating the overall length of that motor vehicle.

[proviso added by GN 205/2004]

Restriction on combination of motor vehicles

241. (1) A person may not operate on a public road any combination of motor vehicles -

- (a) other than a drawing vehicle and one or two trailers;
- (b) other than a motor vehicle drawing one other motor vehicle which is not a trailer, but in the case of an emergency service vehicle a trailer and one other vehicle may be drawn;
- (c) consisting of a trailer attached to a drawing vehicle in such a manner that the combination of trailer and drawing vehicle cannot bend in a horizontal plane, if the combined length of the trailer, including any drawbar or coupling and the rear overhang of the drawing vehicle exceeds three comma one metres;
- (d) if the length of a drawbar of any trailer in such combination, where that trailer has more than one axle, exceeds two metres, but in the case of an underslung coupling, the drawbar may exceed two metres: Provided the distance between the two vehicles does not exceed two comma five metres; or
- (e) if the drawing vehicle is a motorcycle, other than a quadrucycle,

but, subject to regulation 258(2), any combination of vehicles may be towed by a breakdown vehicle if the brake system of the towed combination, excluding the drawing vehicle of that combination, is functional and co-ordinated with the working of the brakes of the breakdown vehicle.

(2) For the purposes of paragraph (a) of subregulation (1), a converter dolly is not, when used in combination with a semi-trailer, deemed to be a trailer.

(3) If the drawing vehicle referred to in subregulation (1) is a motor quadrucycle the gross vehicle mass of the trailer may not be more than the tare of the drawing vehicle.

[regulation 241 substituted by GN 205/2004]

Overall width of vehicle

REGULATIONS
Road Traffic and Transport Act 22 of 1999
Road Traffic and Transport Regulations, 2001

242. A person may not operate on a public road -

- (a) a bus of which the distance between the centre-lines of the tyres of the two front wheels exceeds one comma nine metres, if the overall width of the bus exceeds two comma six metres;
- (b) a goods vehicle, the gross vehicle mass of which is not less than 12 000 kilograms, if the overall width thereof exceeds two comma six metres; or
- (c) any other vehicle, if the overall width thereof exceeds two-and-a- half metres.

Overall height of vehicle and load

243. A person may not operate on a public road a motor vehicle together with any load thereon, if the overall height -

- (a) in the case of a double-decker bus exceeds four comma six five metres;
- (b) in the case of a motor vehicle of which the gross vehicle mass exceeds 3500 kilograms exceeds four comma three metres; and
- (c) in the case of a motor vehicle of which the gross vehicle mass does not exceed 3500 kilograms exceeds three metres.

[regulation 243 substituted by GN 205/2004]

Turning radius and wheelbase

244. A person may not operate on a public road a vehicle -

- (a) if the turning radius of the vehicle exceeds 13,1 metres; and
- (b) if the wheel base of the vehicle exceeds, in the case of -
 - (i) a semi-trailer, nine metres, unless a certificate issued by the inspectorate of manufacturers, builders, importers and number plate manufacturers, which reflects that the cornering, reversing and road damage performance of the semi-trailer presents no greater hazard than for a nine metre wheelbase tandem axle semi-trailer, is affixed to the semi-trailer or carried in the drawing vehicle concerned;
 - (ii) a bus-train, 15 metres; or
 - (iii) any other vehicle, eight-and-a-half metres.

Overhang of vehicle

245. (1) A person may not operate on a public road -

- (a) a semi-trailer, the front overhang of which exceeds one comma eight metres; or
- (b) a vehicle, other than a semi-trailer or trailer with one axle or one axle unit, if the front overhang exceeds -

REGULATIONS
Road Traffic and Transport Act 22 of 1999
Road Traffic and Transport Regulations, 2001

- (i) 60 per cent of the wheel-base;
 - (ii) six comma two metres in the case of a vehicle having the front surface of the back rest of the driver's seat at seat level not more than one comma seven metres from the front end of the vehicle when the seat, if adjustable, is in the rearmost position, less half the wheel-base, but the wheel-base of a bus train is the distance measured from the centre of the front axle to the centre of the middle axle; or
 - (iii) five comma eight metres in the case of any other vehicle, less half the wheel-base.
- (2) A person may not operate on a public road -
- (a) a vehicle designed or adapted for use in connection with street cleaning or the disposal of refuse or sewage, any vehicle referred to in regulation 239, or any bus or self-propelled caravan, if the rear overhang exceeds 70 per cent of its wheel-base;
 - (b) a trailer, other than a semi-trailer, which is equipped with -
 - (i) one axle;
 - (ii) one axle unit; or
 - (iii) two axles and the distance between the centre-lines of the axles is less than one comma two metres, if the rear overhang exceeds 50 per cent of the length of the body of the trailer; or
 - (c) any other vehicle not referred to in paragraph (a) or (b), if the rear overhang exceeds 60 per cent of its wheel-base.

Projections in case of vehicle other than motorcycle or pedal cycle

246. (1) A person may not operate on a public road a vehicle, other than a motorcycle or pedal cycle -

- (a) carrying any goods or fittings which project -
 - (i) either side of the longitudinal centre-line of the vehicle by more than -
 - (aa) in the case of a bus contemplated in regulation 242(a) or a goods vehicle contemplated in regulation 242(b), one comma three metres; or
 - (bb) in the case of any other vehicle, one comma two five metres, but no side mirror or direction indicator on the vehicle must be taken into account;
 - (ii) more than 300 millimetres beyond the front end of the vehicle; or
 - (iii) more than one comma eight metres beyond the rear end of the vehicle; or

REGULATIONS
Road Traffic and Transport Act 22 of 1999
Road Traffic and Transport Regulations, 2001

- (b) if -
 - (i) the front overhang, together with any projection, exceeds the front overhang as contemplated in regulation 245(1); or
 - (ii) any bracket projects more than 150 millimetres beyond the widest part of the vehicle.

(2) A person may not operate on a public road a vehicle or combination of vehicles where the combined length of the vehicle or combination of vehicles and any projection exceeds the overall length prescribed in regulation 240 for that vehicle or combination of vehicles.

Projections in case of motorcycle or pedal cycle

247. A person may not operate on a public road a motorcycle or pedal cycle if any goods carried thereon, or on any portion or side-car of such cycles, project more than 600 millimetres to the front of the axle centre of the front wheel or more than 900 millimetres to the rear of the axle centre of the rear wheel or more than 450 millimetres to either side of the wheels of such cycles, or more than 300 millimetres to the outside of the wheel of any side-car, but this regulation does not apply to any side-mirror or crash bars.

Warning in respect of projecting load

248. (1) A person may not operate a vehicle on a public road if the load on the vehicle projects more than 150 millimetres beyond the side thereof, unless -

- (a) during the period between sunset and sunrise and at any other time when, due to insufficient light or unfavourable weather conditions, persons and vehicles upon the public road are not clearly discernible at a distance of 150 metres, the extent of such projection is indicated -
 - (i) by means of either a white retro-reflector or a lamp emitting a white light, fitted at the outer edge of the front of that load; and
 - (ii) by means of either a red retro-reflector or a lamp emitting a red light, fitted at the outer edge of the rear of that load; and
- (b) during any other period, the extent of that projection is indicated by means of flags of red cloth, not less than 300 millimetres by 300 millimetres, suspended by two adjacent corners thereof transversely to the direction of travel of the vehicle from the front and rear of that projection.

(2) A person may not operate a vehicle on a public road if the load on the vehicle projects more than 300 millimetres beyond the rear thereof unless -

- (a) during the period between sunset and sunrise and at any other time when, due to insufficient light or unfavourable weather conditions, persons and vehicles upon the public road are not clearly discernible at a distance of 150 metres -
 - (i) the width of the projection is indicated by means of red retro-reflectors or lamps emitting a red light fitted on the end of such projection. but where the width of that projection is less than 600 millimetres it is sufficient for the

REGULATIONS
Road Traffic and Transport Act 22 of 1999
Road Traffic and Transport Regulations, 2001

purpose of indicating that width to fit one retro-reflector or lamp on the end thereof; and

(ii) the length of that projection is indicated by means of yellow retro-reflectors or lamps emitting a yellow light fitted on both sides of that projection at the end thereof; and

(b) during any other period, the length of that projection is indicated by means of a red flag or red cloth, not less than 300 millimetres by 300 millimetres, suspended by two adjacent corners thereof transversely to the direction of travel of the vehicle, from the end of that projection and the width of that projection is indicated by means of such flags suspended by two adjacent corners thereof parallel to the direction of travel of the vehicle, from both sides of such projection at the end thereof, but where the width of that projection is less than 600 millimetres it is sufficient for the purposes of indicating that projection, to suspend one such flag from the end thereof.

(3) For the purposes of this regulation, the light of any lamp must comply with regulation 174(2).

Certain vehicles exempt from certain regulations of this Part

249. (1) Except for a breakdown vehicle, any vehicle which is a drilling machine (excluding a motor vehicle which permanently incorporates drilling equipment), a mobile crane, a fork lift or straddle truck or a road making machine, earthmoving machine, excavation machine, construction machine or loading machine is exempt from this Part, except for -

(a) regulation 243 (Overall height of vehicle and load);

(b) regulation 245 (Overhang of vehicle).

(2) The exemptions provided for in subregulation (1), are subject to the following conditions:

(a) Those vehicles may not be operated on the roadway of a public road during the period between sunset and sunrise and at any other time when, due to insufficient light or unfavourable weather conditions, persons and vehicles upon the public road are not clearly discernible at a distance of 150 metres;

(b) the overall width of any such vehicle may not exceed three and a half metres;

(c) the driver of any such vehicle on the roadway of a public road must stop such vehicle, and where possible, drive it off the roadway if necessary in order to allow other vehicular traffic to pass;

(d) any such vehicle exceeding the overall length prescribed in regulation 240 or the overall width prescribed in regulation 242 must display two flags of red cloth not less than 600 millimetres by 600 millimetres, in such manner as to indicate its abnormal length or width and such flags must be suspended from the vehicle transversely to the direction of travel; and

REGULATIONS
Road Traffic and Transport Act 22 of 1999
Road Traffic and Transport Regulations, 2001

- (e) those vehicles, other than a mobile crane which is operated for the purpose of removing any hazard or obstruction on a freeway, may not be operated on a freeway.

(3) Any vehicle, including a tractor, which is not a goods vehicle and which is used solely for bona fide agricultural, horticultural, viticultural or pastoral pursuits and when operated on a public road, is exempt from this Part, except for regulation 243, in so far as it relates to the tare, gross vehicle mass and maximum permissible drawing vehicle mass.

(4) The exemption provided for in subregulation (3), are subject to the following conditions:

[The verb “are” should be “is” to accord with the subject “exemption”.]

- (a) Those vehicles may not be operated on the roadway of a public road during the period between sunset and sunrise and at any other time when, due to insufficient light or unfavourable weather conditions, persons and vehicles upon the public road are not clearly discernible at a distance of 150 metres;

- (b) the driver of any such vehicle on the roadway of a public road must stop such vehicle and, where possible, drive it off the roadway if necessary in order to allow other vehicular traffic to pass;

- (c) any such vehicle -

- (i) exceeding the overall length prescribed in regulation 240;
- (ii) encroaching beyond half the width of the roadway except when overtaking other vehicles or crossing bridges; or
- (iii) which is more than two comma six metres but less than three and a half metres wide,

must display two flags of red cloth not less than 600 millimetres by 600 millimetres in such manner as to indicate its abnormal length or width and such flags must be suspended from the vehicle transversely to the direction of travel, but the vehicle may be fitted with amber flashing lights in lieu of such flags; and

- (d) the overall width of any such vehicle may not exceed four and a half metres, but when the overall width exceeds three and a half metres -

- (i) such vehicle may not normally encroach beyond half the width of the roadway except when overtaking other vehicles or crossing bridges; and
- (ii) if such vehicle does encroach beyond half the width of the roadway, two escort vehicles with the headlamps switched on and displaying red flags of the size prescribed in paragraph (c) or amber flashing lights must be provided, one travelling in front and one to the rear of such vehicle; and

- (e) those vehicles may not be operated on a freeway.

PART 5
LOADS ON VEHICLES

REGULATIONS
Road Traffic and Transport Act 22 of 1999
Road Traffic and Transport Regulations, 2001

Manner in which children are to be counted for purposes of these regulations

250. For the purposes of establishing the number of persons that may in terms of these regulations, except regulation 282, be carried on any vehicle, other than a motorcycle or pedal cycle -

- (a) any child under the age of three years is not counted;
- (b) two children of three years or over but under the age of six years are counted as one person; and
- (c) three children of six years or over but under the age of 13 years are counted as two persons,

and in applying this regulation fractions may be disregarded.

Mass of person and luggage for determining mass of load

251. For the purpose of establishing the maximum mass of persons and luggage that may be conveyed on a motor vehicle -

- (a) the mass of a person together with his or her personal effects is, subject to regulation 250 taken as 63 kilograms; and
- (b) in the case of a motor vehicle which is fitted with -
 - (i) a luggage compartment, the mass of luggage is calculated at the rate of 100 kilograms per cubic metre; or
 - (ii) a roof rack, the mass of luggage is calculated at the rate of 75 kilograms per square metre of area of the roof rack,

but where a motor vehicle is examined for the purpose of obtaining a certificate as contemplated in regulations 101 and 157, this regulation does not apply in the determination of the seating capacity of the motor vehicle.

Number of persons that may be carried on vehicle in relation to seating capacity

252. (1) Subject to regulation 250, a person may not operate on a public road a motor vehicle, other than a minibus or bus which is used for hire or reward, motorcycle or pedal cycle if -

- (a) the number of persons on any seat of that vehicle exceeds the number of persons for whom seating accommodation is provided on that seat at the rate of 380 millimetres per person measured at the widest part of the seat with the doors closed; and
- (b) the total number of persons carried on that vehicle, excluding persons carried in the goods compartment of the vehicle, exceeds the number of persons for whom seating accommodation, determined in the manner referred to in paragraph (a), is available in that vehicle;

REGULATIONS
Road Traffic and Transport Act 22 of 1999
Road Traffic and Transport Regulations, 2001

- (c) despite paragraph (b), one child over the age of three years, but under the age of six years may be carried on each transverse seat in excess of the number of persons for whom seating accommodation determined in the manner referred to in paragraph (a) is available on that seat.

(2) Subject to regulation 250, a person may not operate on a public road a bus or minibus, if the number of persons on any seat exceeds the number of persons for whom seating accommodation is provided on that seat at the rate of -

- (a) 400 millimetres per person in the case of a bus; or
(b) 380 millimetres per person in the case of a minibus,

measured at the widest part of the seat with the doors closed.

- (3) For the purposes of subregulation (1)(c), a row of seats is regarded as one seat.

(4) Where in this regulation a reference is made to a maximum or minimum dimension, a tolerance of 10 millimetres above or below any such maximum or minimum is permissible.

Permissible maximum axle mass load of vehicle

253. (1) A person may not operate on a public road a minibus, bus, tractor or goods vehicle if the permissible maximum axle mass load of the vehicle is exceeded.

(2) The permissible maximum axle mass load of a vehicle is the least of the mass limits determined by -

- (a) regulation 257(1) in respect of a vehicle fitted with pneumatic tyres or regulation 257(2) and 262 in respect of a vehicle fitted with tyres other than pneumatic tyres;
(b) regulation 258(1)(a)(ii); and
(c) regulation 259(a), (b) and (c).

Permissible maximum axle unit mass load of vehicle

254. (1) A person may not operate on a public road a minibus, bus, tractor or goods vehicle if the permissible maximum axle unit mass load of the vehicle is exceeded.

(2) The permissible maximum axle unit mass load of a vehicle is the least of the mass limits determined by -

- (a) regulation 257(1) in respect of a vehicle fitted with pneumatic tyres or regulations 257(2) and 262 in respect of a vehicle fitted with tyres other than pneumatic tyres;
(b) regulation 258(1)(a)(ii); and
(c) regulation 259(d), (c), (f) and (g).

Permissible maximum vehicle mass

REGULATIONS
Road Traffic and Transport Act 22 of 1999
Road Traffic and Transport Regulations, 2001

255. (1) A person may not operate on a public road a minibus, bus, tractor or goods vehicle if the permissible maximum vehicle mass of the vehicle is exceeded.

(2) The permissible maximum vehicle mass of a vehicle is the least of the mass limits determined by -

- (a) the sum of all the permissible maximum axle mass loads and axle unit mass loads of the vehicle as contemplated in regulations 253 and 254;
- (b) regulation 258(1)(a)(i);
- (c) regulation 258(2);
- (d) regulation 258(3); and
- (e) regulation 260,

but the permissible maximum vehicle mass of such vehicle may not exceed 56 000 kilograms.

Permissible maximum combination mass

256. (1) A person may not operate on a public road a combination of vehicles where the drawing vehicle is a minibus, bus, tractor or goods vehicle, if the permissible maximum combination mass of that combination is exceeded.

(2) The permissible maximum combination mass of a combination of vehicles is the least of the mass limits determined by -

- (a) the sum of all the permissible maximum axle mass loads and axle unit mass loads of the combination of vehicles as contemplated in regulations 253 and 254;
- (b) regulation 258(1)(b);
- (c) regulation 258(2);
- (d) regulation 258(3); and
- (e) regulation 260,

but the permissible maximum combination mass of such combination may not exceed 56 000 kilograms.

Load on tyres

257. (1) A person may not operate a motor vehicle on a public road -

- (a) which is fitted with pneumatic tyres, if any wheel mass load is in excess of the wheel mass load referred to in the appropriate part of the standard specification of the South African Bureau of Standards, SABS 1550:1992 "Motor vehicle tyres and rims: dimensions and loads", Part I "General", Part 2 "Passenger car tyres", Part 3 "Commercial vehicle tyres" published by the South African Government Notice No. 2006 of 17 July 1992; or

REGULATIONS
Road Traffic and Transport Act 22 of 1999
Road Traffic and Transport Regulations, 2001

- (b) which is fitted with a pneumatic tyre that is not mentioned in the standard specification referred to in paragraph (a), if the wheel mass load is in excess of the wheel mass load approved by the manufacturer of the tyre concerned.

(2) For the purposes of determining the pressure in a tyre, the temperature of the tyre is disregarded.

(3) A person may not operate any vehicle on a public road fitted with tyres, other than pneumatic tyres, if the wheel mass load exceeds eight kilograms per one millimetre width of any such tyre.

Gross vehicle mass, gross axle mass load, gross axle unit mass load, gross combination mass, power/mass ratio and axle mass load of driving axle/total mass ratio not to be exceeded

258. (1) A person may not operate on a public road a minibus, bus, tractor or goods vehicle -

- (a) if -
- (i) the gross vehicle mass;
 - (ii) any gross axle mass load; or
 - (iii) any gross axle unit mass load,
- is exceeded;

(b) drawing any other motor vehicle if the gross combination mass is exceeded.

(2) A person may not operate on a public road a vehicle which is a minibus, bus, tractor or goods vehicle if the mass in kilograms of that vehicle or of a combination of vehicles of which the first-mentioned vehicle forms a part, whether laden or unladen, exceeds a figure arrived at by multiplying the net power in kilowatts of the engine of that vehicle as determined in accordance with or calculated with due regard to the Code of Practice of the South African Bureau of Standards SABS 013 "The determination of performance (at net power) of internal combustion engines" Part I: 1988 "Road vehicle internal combustion engines at sea level" published by the South African Government Notice No. 1652 of 19 August 1988 -

- (a) in the case of the drawing vehicle being a tractor, by 400; or
- (b) in the case of any other drawing vehicle, by 240.

(3) A person may not operate a vehicle on a public road which is a minibus, bus, tractor or goods vehicle if the mass in kilograms of that vehicle or of a combination of vehicles of which the first-mentioned vehicle forms a part, whether laden or unladen, exceeds five times the total axle mass load of the driving axle or axles of such vehicle.

Mass load carrying capacity of road

259. A person may not operate on a public road a motor vehicle or combination of motor vehicles, which is fitted with wheels with pneumatic tyres, if -

REGULATIONS
Road Traffic and Transport Act 22 of 1999
Road Traffic and Transport Regulations, 2001

- (a) the wheel mass load of wheels -
 - (i) which are fitted to a steering axle, exceeds 3 850 kilograms; or
 - (ii) which are fitted to axles other than a steering axle, exceeds 4 000 kilograms;
- (b) the axle mass load of an axle fitted with two or three wheels and -
 - (i) which is a steering axle, exceeds 7 700 kilograms; or
 - (ii) which is an axle other than a steering axle, exceeds 8 000 kilograms;
- (c) the axle mass load of an axle fitted with four wheels and -
 - (i) which is fitted to a vehicle designed to compact refuse and which is carrying such refuse, exceeds 10 200 kilograms;
 - (ii) which is fitted to a breakdown vehicle, exceeds 10 200 kilograms;
 - (iii) which is placed in the rear or middle of a bus-train, exceeds 10 200 kilograms;
 - (iv) which is fitted to a bus, other than a bus-train, exceeds 10 200 kilograms; or
 - (v) which is not mentioned in subparagraphs (i) to (iv), exceeds 9 000 kilograms;
- (d) the axle mass load of an axle unit consisting of two axles, each of which are fitted with two or three wheels, and -

[The verb “are” should be “is” to accord with the subject “each”.]

 - (i) which is a steering axle unit, exceeds 15 400 kilograms; or
 - (ii) which is an axle unit other than a steering axle unit, exceeds 16 000 kilograms;
- (e) the axle mass load of an axle unit which consists of two axles, each of which are fitted with four wheels, and -

[The verb “are” should be “is” to accord with the subject “each”.]

 - (i) which is fitted to a vehicle, except a trailer, designed to compact refuse and which is carrying such refuse, exceeds 20 400 kilograms;
 - (ii) which is fitted to a breakdown vehicle, exceeds 20 400 kilograms; or
 - (iii) which is not mentioned in subparagraphs (i) and (ii), exceeds 18 000 kilograms;
- (f) the axle mass load of an axle unit which consists of three axles, each of which are fitted with two or three wheels, and -

[The verb “are” should be “is” to accord with the subject “each”.]

REGULATIONS
Road Traffic and Transport Act 22 of 1999
Road Traffic and Transport Regulations, 2001

- (i) which is a steering axle unit, exceeds 23 100 kilograms; or
- (ii) which is an axle unit other than a steering axle unit, exceeds 24 000 kilograms;
- (g) the axle mass load of an axle unit which consists of three or more axles, each of which are fitted with four wheels, exceeds 24 000 kilograms.

[The verb “are” should be “is” to accord with the subject “each”.]

Mass load carrying capacity of bridges

260. (1) A person may not operate on a public road a vehicle or combination of vehicles, which is fitted with wheels with pneumatic tyres, if the total axle mass load of any group of axles of such vehicle or combination of vehicles exceeds the mass in kilograms determined by multiplying the dimension of such group measured as referred to in subregulation (3) by 2 100 and adding 18 000.

(2) A group of axles referred to in subregulation (1) may comprise any series of axles, but may not consist of only one axle unit as referred to in regulation 259(d), (e), (f) or (g).

- (3) (a) The dimension referred to in subregulation (1) is measured in metres and tenths of metres from the centre of the first axle of any group of axles to the centre of the last axle of that group.
- (b) If the dimension so measured is not a definite figure in metres and tenths of a metre, the next highest number of tenths of a metre with which the dimension so measured is exceeded, must be used for the calculation referred to in subregulation (1).
- (c) Where a group of axles of a combination of vehicles is measured, the vehicles of that combination must be positioned in line and both sides of that combination of vehicles must be measured, and if the dimensions of the two sides differ, the longer dimension must be used for the calculation referred to in subregulation (1).

Distribution of axle mass load and wheel mass load on vehicle fitted with pneumatic tyres

261. Despite regulation 259, a person may not operate a motor vehicle which is fitted with pneumatic tyres on a public road if -

- (a) on an axle with -
 - (i) two tyres, the wheel mass load on one tyre exceeds the wheel mass load on the other tyre by more than 10 per cent; or
 - (ii) four tyres, the wheel mass load on two tyres nearest to each other exceeds the wheel mass load on the other two tyres by more than 10 per cent;
- (b) in the case of an articulated motor vehicle the axle mass load of a steering axle or the sum of the axle mass loads of a steering axle unit is less than 11 per cent of the sum of all axle mass loads of the vehicle;

REGULATIONS
Road Traffic and Transport Act 22 of 1999
Road Traffic and Transport Regulations, 2001

- (c) in the case of a motor vehicle, not being an articulated motor vehicle, with a steering axle unit, the sum of the axle mass loads of that steering axle unit is less than 30 per cent of the sum of all axle mass loads of the vehicle; or
- (d) in the case of any other vehicle, the axle mass load of a steering axle is less than 20 per cent of the sum of all axle mass loads of the vehicle, except in the case of a tractor when the axle mass load of the steering axle may not be less than 12 per cent of the sum of all the axle mass loads of the tractor.

Axle mass load of vehicles fitted with tyres other than pneumatic tyres

262. A person may not operate a vehicle on a public road fitted -

- (a) with metal tyres, if any axle mass load of the vehicle exceeds 2 700 kilograms; or
- (b) with tyres, other than pneumatic or metal tyres, if any axle mass load or the sum of all axle mass loads of the vehicle exceeds 50 per cent of that permitted for vehicles fitted with pneumatic tyres in terms of regulation 259 or, if the axle mass load of any steering axle of that vehicle does not comply with the requirements of regulation 261(b), (c) or (d).

Information to be displayed on certain vehicles

263. A person may not operate a minibus, bus, or goods vehicle which, according to its registration certificate was registered for the first time prior to 1 January 2002 and with a gross vehicle mass not exceeding 3 500 kilograms, on a public road unless there is displayed in a conspicuous position on the left side thereof in letters and figures of not less than 40 millimetres in height and which must be clearly legible at all times -

- (a) the tare of the vehicle in kilograms (denoted as T);
- (b) the permissible maximum vehicle mass referred to in regulation 255 in kilograms (denoted as V); and
- (c) if the vehicle is used to draw any other vehicle, the permissible maximum drawing vehicle mass which is the least of the masses determined in terms of regulation 258(1)(b), (2) or (3) in kilograms (denoted as DH),

but if that vehicle is fitted with a plate as referred to in regulation 264, this regulation does not apply to that vehicle.

[regulation 263 amended by GN 205/2004]

Information plates on certain vehicles

264. (1) A person may not operate a minibus, bus, or goods vehicle which, according to its registration certificate -

- (a) was registered for the first time prior to 1 January 2002 and with a gross vehicle mass that exceeds 3 500 kilograms; or
- (b) was registered for the first time on or after 1 January 2002, on a public road, unless the following particulars in respect of the minibus, bus or goods vehicle are clearly

REGULATIONS
Road Traffic and Transport Act 22 of 1999
Road Traffic and Transport Regulations, 2001

imprinted or stamped on a metal plate or plates affixed in an accessible place on a door post, under the bonnet or on the dash-board of the vehicle concerned or, in the case of a trailer, on the left side thereof in any conspicuous place:

- (i) The tare in kilograms (denoted as T);
- (ii) the gross vehicle mass in kilograms (denoted as GYM);
- (iii) the gross axle mass load or gross axle unit mass load of each axle or axle unit in kilograms (denoted as GA or GAU respectively);
- (iv) in the case of a semi-trailer the gross kingpin mass load as specified by the manufacturer (denoted as GKM);
- (v) the gross combination mass in kilograms where the vehicle is used to draw any other vehicle (denoted as GCM);
- (vi) where applicable, the net power in kilowatts as determined in accordance with or calculated with due regard to the Code of Practice of the South African Bureau of Standards SABS 013:1977 "The determination of performance (at net power) of internal combustion engines": Part 1 - 1977 "Road vehicle internal combustion engines at sea level" published by the South African Government Notice No. 463 of 9 July 1982 (denoted as P);
- (vii) the permissible maximum vehicle mass referred to in regulation 255 in kilograms (denoted as V), but this subparagraph does not apply to a semi-trailer;
- (viii) the permissible maximum axle mass load referred to in regulation 253 or axle unit mass load referred to in regulation 254 of each axle or axle unit in kilograms (denoted as A or AU respectively); and
- (ix) the permissible maximum drawing vehicle mass referred to in regulation 263(c) (denoted as D).

(2) A person may not operate on a public road a tractor which according to its registration certificate was registered for the first time on or after 1 January 2002, unless a metal plate upon which -

- (a) the net power of the engine in kilowatts as determined in terms of the Code of Practice referred to in subregulation (1)(b)(vi) (denoted as "P");
- (b) the gross combination mass in kilograms (denoted as "GCM"); and
- (c) the permissible maximum drawing vehicle mass referred to in regulation 263 (c) (denoted as "D"),

clearly imprinted or stamped, is affixed to that tractor in any accessible place.

Manner in which goods to be carried

265. A person may not operate a motor vehicle on a public road carrying any goods -

REGULATIONS
Road Traffic and Transport Act 22 of 1999
Road Traffic and Transport Regulations, 2001

- (a) in such a manner as to come into contact with the surface of the public road on which the vehicle is being operated, but a chain, known as a “static chain”, may be carried in contact with the surface of such road;
- (b) in such manner as to obscure the driver’s view of traffic to the front or on either side, or his or her view in the rear-view mirror or mirrors of traffic to the rear;
- (c) which are not -
 - (i) safely contained within the body of the vehicle; or
 - (ii) securely fastened to that vehicle,

and which are not properly protected from being dislodged or spilled from that vehicle;
- (d) on the roof thereof, in the case where the vehicle is a motorcar, if the height of the goods measured from the highest point of the roof exceeds one-half of the height of the motor car, measured from ground level, but this paragraph does not apply to pedal cycles being transported on the roof of a motor vehicle; or
- (E) in any container, which has provision for fastening by means of “twist locks”, unless the container is securely fastened by at least four “twist locks” and this paragraph also applies to empty containers carried on a motor vehicle, but two “twist locks” may be used to fasten a container which, measured parallel to the length of the vehicle, is at least one comma five metre in length and less than three metres in length.

Carrying of persons on goods vehicle

266. (1) A person may not -

- (a) operate a goods vehicle conveying passengers on or in the goods compartment of that vehicle on a public road; or
- (b) convey passengers on a public road in the goods compartment of a goods vehicle,

in excess of a maximum of 6 passengers.

(2) A person conveying passengers in terms of subregulation (1) must convey passengers in a motor vehicle -

- (a) not exceeding a GVM of 3 500 kilogram; and
- (b) provided that the goods compartment of that goods vehicle in which such persons are conveyed is enclosed -
 - (i) with a running board to a height of 350 millimeters above the surface upon which such person is seated; or
 - (ii) to a height of at least 900 millimeters from the floor surface upon which such person is seated.

REGULATIONS
Road Traffic and Transport Act 22 of 1999
Road Traffic and Transport Regulations, 2001

[GN 98/2016 states that it is substituting paragraph (b), but this would produce a nonsensical result. It appears to have been intended to substitute only subparagraph (ii), which previously read as follows:

- “(ii) 900 millimeters above the surface on which such person is standing, in a manner and with a material of sufficient strength to prevent such person from falling from the vehicle when it is in motion.”]

[regulation 266 substituted by GN 156/2015]

Presumptions

267. (1) If, in a prosecution for an offence under regulations 253 to 262 inclusive, an allegation is made in the charge sheet or summons in relation to -

- (a) the gross vehicle mass;
- (b) the gross axle mass;
- (c) the gross axle unit mass load;
- (d) the gross combination mass;
- (e) the net power in kilowatts of any bus or goods vehicle;
- (f) the permissible maximum vehicle mass referred to in regulation 255;
- (g) the permissible maximum combination mass referred to in regulation 256; or
- (h) the permissible maximum axle mass load or maximum axle unit mass load, referred to in regulation 253 or 254 respectively,

the allegation is, in the absence of evidence to the contrary, presumed to be correct.

(1A) The mass load of a motor vehicle must be determined as contemplated in section 87 of the Act by a weighbridge consisting of one or more weighing instruments (also referred to as mass measuring equipment) that is verified in terms of NAMS R-76:2014: “Non-Automatic Weighing Instruments; Part 1 – Metrological and Technical Requirements–Tests”.

[subregulation (1A) inserted by GN 290/2008 and substituted by GN 98/2016]

(1B) Despite anything to the contrary contained in the standards referred to in subregulation (1), the person who verifies the operation of the weighbridge, must -

- (a) be in possession of at least a recognised national diploma in an engineering or any technical related qualification approved by the Namibian Standards Institution; and
- (b) be certified to be competent to verify a weighbridge as contemplated in subregulation (1) by the Namibia Standards Institution (NSI) or any organisation approved by the Minister.

[subregulation (1B) inserted by GN 98/2016]

REGULATIONS
Road Traffic and Transport Act 22 of 1999
Road Traffic and Transport Regulations, 2001

(1C) Where the person referred to in subregulation (1B) is required to verify a weighbridge in terms of the standards referred to in subregulation (1A), the person must verify each weighing instrument of a combination of weighing instruments.

[subregulation (1C) inserted by GN 98/2016]

(2) The fact that differing results may be obtained on successive attempts at determining the axle mass load of an axle which is part of an axle unit does not, by itself, prove the mass load alleged in a prosecution, to be incorrect.

(3) In a prosecution for an alleged offence in terms of regulation 260, any distance in metres alleged on the charge sheet or summons, used to calculate the maximum permissible mass load of any group of axles on the approved form, is in the absence of evidence to the contrary, deemed to be correct.

(4) The mass loads of all the individual axles of -

- (a) an axle unit, may be added to obtain the total mass load of the axle unit;
- (b) a group of axles, may be added to obtain the total mass load of the group of axles;
- (c) a vehicle, may be added to obtain the total mass load of the vehicle; or
- (d) a combination of vehicles, may be added to obtain the total mass load of the combination of vehicles.

(5) Notwithstanding anything to the contrary contained in these regulations, where an owner of a motor vehicle has been issued with a motor vehicle licence for the vehicle, the owner is not competent, in respect of the year to which the licence is applicable, to prove that the tare of that vehicle is either greater or less than the tare upon which the fees payable for that licence were calculated, but this subregulation does not apply in respect of an owner of a motor vehicle who is prosecuted for and found guilty of a contravention of section 84 of the Act where the contravention relates to the tare referred to in this subregulation.

Certain vehicles exempt from certain regulations of this Part

268. (1) Except for a breakdown vehicle, any vehicle, which is a drilling machine, a mobile crane, a fork lift, a straddle truck, a road making machine, an earthmoving machine, an excavation machine, a construction machine or a loading machine, is, when operated on a public road, exempt from the regulations in this Part, except for -

- (a) regulation 253 (Permissible maximum axle mass load of vehicle);
- (b) regulation 254 (Permissible maximum axle unit mass load of vehicle);
- (c) regulation 255 (Permissible maximum vehicle mass);
- (d) regulation 256 (Permissible maximum combination mass);
- (e) regulation 257 (Load on tyres);

REGULATIONS
Road Traffic and Transport Act 22 of 1999
Road Traffic and Transport Regulations, 2001

- (f) regulation 258 (Gross vehicle mass, gross axle mass load, gross axle unit mass load, gross combination mass, power/mass ratio and axle mass load of driving axle/total mass ratio not to be exceeded);
- (g) regulation 259 (Mass load carrying capacity of road);
- (h) regulation 260 (Load carrying capacity of bridges);
- (i) regulation 261 (Distribution of axle mass load and wheel mass load on vehicle fitted with pneumatic tyres);
- (j) regulation 262 (Axle mass load of vehicles fitted with tyres other than pneumatic tyres);
- (k) regulation 263 (Information to be displayed on certain vehicles);
- (l) regulation 264 (Information plates on certain vehicles).

(2) Any vehicle, including a tractor, which is not a goods vehicle and which is used solely for bona fide agricultural, horticultural, viticultural or pastoral pursuits and when operated on a public road, is exempt from the regulations in this Part, except for -

- (a) regulation 253 (Permissible maximum axle mass load of vehicle);
- (b) regulation 254 (Permissible maximum axle unit mass load of vehicle);
- (c) regulation 255 (Permissible maximum vehicle mass);
- (d) regulation 256 (Permissible maximum combination mass);
- (e) regulation 257 (Load on tyres);
- (f) regulation 258 (Gross vehicle mass, gross axle mass load, gross axle unit mass load, gross combination mass, power/mass ratio and axle mass load of driving axle/total mass ratio not to be exceeded);
- (g) regulation 259 (Mass load carrying capacity of road);
- (h) regulation 260 (Mass load carrying capacity of bridges);
- (i) regulation 261 (Distribution of axle mass load and wheel mass load on vehicle fitted with pneumatic tyres);
- (j) regulation 262 (Axle mass load of vehicle fitted with tyres other than pneumatic tyres);
- (k) regulation 263 (Information to be displayed on certain vehicles);
- (l) regulation 264 (Information plates on certain vehicles),

in so far as those regulations relate to the tare, gross vehicle mass and maximum permissible drawing vehicle mass.

REGULATIONS
Road Traffic and Transport Act 22 of 1999
Road Traffic and Transport Regulations, 2001

(3) The exemptions provided for in subregulations (1) and (2) are subject to the following conditions:

- (a) Those vehicles may not be operated on the roadway of a public road during the period between sunset and sunrise and at any other time when, due to insufficient light or unfavourable weather conditions, persons and vehicles upon the public road are not clearly discernible at a distance of 150 metres;
- (b) the driver of any such vehicle on the roadway of a public road must stop such vehicle, and where possible, drive it off the roadway if necessary in order to allow other vehicular traffic to pass;
- (c) those vehicles, other than a mobile crane which is operated for the purpose of removing any hazard or obstruction on a freeway, may not be operated on a freeway.

(4) Any vehicle owned by the Ministry of Defence and which is not designed or adapted for the carriage of goods or passengers are excluded from the provisions of these regulations relating to the construction or equipment of vehicles, except for regulations 253,254,255,256,259, 260 and 261.

PART 6
PROVISIONS RELATING TO PASSENGER CARRYING VEHICLES

Persons not to be carried in goods compartment for reward

269. A person may not carry any persons for reward in the goods compartment of a motor vehicle on a public road.

Sides and roof

270. A person may not operate a minibus or bus on a public road unless -

- (a) the sides of the passenger compartment are enclosed to the height of at least 600 millimetres from the floor with material which is durable and weather-proof; and
- (b) the minibus or bus is provided with a weatherproof roof.

Entrances, exits and emergency exits of minibuses and buses

271. (1) (a) A minibus or bus must be equipped with at least one passenger entrance leading from the left hand side of the minibus or bus to the passenger compartment, in addition to any doors provided for the driver and front seat passenger.

(b) A minibus must have at least one emergency exit on the right hand side or in the rear thereof, but a door fitted for use by the driver of the minibus which is accessible to persons in the passenger compartment thereof is deemed to be such an emergency exit.

(c) A bus or the lower deck of a double-decker bus must have at least one emergency exit -

REGULATIONS
Road Traffic and Transport Act 22 of 1999
Road Traffic and Transport Regulations, 2001

- (i) in the rear; or
- (ii) on each side towards the rear,

but in the case of a single deck bus an emergency exit may be fitted in the roof of the bus in place of the emergency exit required on the left hand side.

- (d) The upper deck of a double-decker bus must have at least one emergency exit -
 - (i) in the rear; or
 - (ii) on each side and in the roof of the upper deck.
- (e) Each emergency exit must have dimensions of at least 900 by 450 millimetres and must be possible to be opened from inside and outside and may not open inwards.
- (f) An emergency exit may not be so positioned that the passengers have to pass through a goods compartment of a minibus or bus or via the stairs of a double-decker bus to reach the emergency exit.
- (g) Escape hatches, knock-out windows or knock-out panels may be used as emergency exits and if a minibus or bus is operated for reward such hatches, windows or panels must be marked with the words "emergency exit" on the inside and outside in letters of at least 50 millimetres in height.
- (h) A door of the size and operating characteristics referred to in paragraph (e) may be used as an emergency exit.
- (i) An entrance for persons, other than the driver, may not be provided on the right hand side of the longitudinal centre-line of a minibus or bus operating for reward.

(2) In the case of a minibus or bus that has been converted from a goods vehicle, the requirements of subparagraphs (a), (b), (c), (f), (g) and (h) of subregulation (1) are deemed to be satisfied if openings complying with the requirements of subregulation (1)(c) are provided.

Entrances and exits to be fitted with doors

- 272.** A person may not operate a minibus or bus on a public road unless -
- (a) every entrance to or exit from the minibus or bus is fitted with a door or other effective barrier; and
 - (b) the door or barrier is properly closed when the minibus or bus is in motion with persons thereon.

Stairs

273. The stairs to the upper deck of a double-decker bus must be provided with a handrail on each side and a partition or screen at each side of the stairs of sufficient strength to prevent any person from slipping off the side of any step.

Passageways

REGULATIONS
Road Traffic and Transport Act 22 of 1999
Road Traffic and Transport Regulations, 2001

274. A person may not operate a bus on a public road, unless the passenger compartment of the bus has an unimpeded longitudinal passageway with a cross passageway from each entrance of the bus to the longitudinal passageway, and the passageways are at least -

- (a) 300 millimetres wide from floor to seat level; and
- (b) 350 millimetres wide above seat level.

Seats

275. (1) A person may not operate a bus on a public road unless the driver's seat of the bus is adjustable and has a partition immediately behind it and is so placed as to afford the driver ample space for controlling the bus.

(2) Subject to subregulation (3), a person may not operate a minibus or a bus on a public road unless the seats provided for passengers in the minibus or bus have -

- (a) a backrest of which the -
 - (i) top must be at least 350 millimetres from seat level;
 - (ii) bottom must be not more than 200 millimetres from seat level;
 - (iii) width, including the frame, must be at least 340 millimetres,for every passenger for whom seating accommodation is provided on the seats;
- (b) a seat height from the floor or foot rest of the seat to seat level of at least 250 millimetres except where a seat is situated over a wheel arch where no limit applies;
- (c) a seat depth from the front of the seat to the front of the backrest of at least 340 millimetres;
- (d) a seat width as referred to in regulation 252(2);
- (e) in the case where a seat faces a partition or similar obstruction, a horizontal distance between the front of the backrest of that seat at seat level to that partition or obstruction of at least 570 millimetres;
- (f) in the case where seats face each other, in the horizontal distance between the front of the backrest of every such seat at seat level of at least 1200 millimetres; and
- (g) in the case where seats face in the same direction, a horizontal distance between the front of the backrest of any such seat at seat level and the back of the backrest of the seat in front, of at least 570 millimetres.

(3) Where in subregulation (2) a reference is made to a maximum or minimum dimension, a tolerance of 10 millimetres above any such maximum and below any such minimum is permissible.

REGULATIONS
Road Traffic and Transport Act 22 of 1999
Road Traffic and Transport Regulations, 2001

(4) A seat in a bus may not face an entrance or have a side of the seat opposite an entrance, unless a rail or partition is provided between that seat and entrance, but a rail may be fixed to the seat if the side of that seat faces an entrance.

(5) Every seat in a minibus or bus must be securely fixed to the minibus or bus.

Goods carried on minibus or bus conveying persons for reward

276. A person may not carry goods in a minibus or bus conveying persons for reward unless the goods -

- (a) are placed in a suitable goods compartment or container;
- (b) are so placed that it do not constitute a danger to the persons being conveyed; and
- (c) do not obstruct any entrance, exit or passageway of the minibus or bus.

Windows and windscreens

277. (1) A minibus or bus designed to have windows -

- (a) must have a continuous row of windows on the left and right hand side of the passenger compartment and the windows, other than the windows of entrance and exit doors, and the first and the last side window must each have a frame, in the case of -
 - (i) a minibus, of not less than 345 millimetres by 450 millimetres; and
 - (ii) a bus, of not less than 450 millimetres by 450 millimetres;
- (b) must have an overall window area of not less than 25 per cent of the floor area of the passenger compartment;
- (c) other than a bus fitted with a system of forced ventilation induced by mechanical means, whether the bus is stationary or in motion, must have windows which can be opened to the same extent so that the total area of the open spaces is not less than five per cent of the floor area of the passenger compartment; and
- (d) may have other windows in addition to those referred to in paragraph (a), (b) or (c).

(2) At least every alternate window in each side of a minibus or bus operating for reward, other than a bus equipped with a system of forced ventilation induced by mechanical means, whether the bus is stationary or in motion, must be capable of being opened.

(3) A window in a bus may not be fitted in a manner that it is possible for a person seated in a normal position to put his or her elbow out of the window, while it is opened.

(4) Every window-pane, windscreen and transparent partition of a minibus or bus must be maintained in a sound, unbroken and clear condition.

Fuel tanks, receptacles and pipes

278. (1) A minibus or bus -

REGULATIONS
Road Traffic and Transport Act 22 of 1999
Road Traffic and Transport Regulations, 2001

- (a) must have fuel tanks, fuel receptacles and fuel pipes which are free of leaks and which are not placed inside the body or steering cabin; and
 - (b) must have the filling opening of a fuel tank placed outside the body or steering cabin.
- (2) No main fuel tank may be placed close to the engine of a bus.

Fire extinguishers

279. (1) Every minibus operating for reward must carry in a readily accessible position at least one fire extinguisher which must be of -

- (a) the dry powder type with a capacity of at least one kilogram; or
- (b) the halogenated hydrocarbon type (BCF) with a capacity of at least one kilogram, and which must be in good working order.

(2) Every bus operating for reward must carry in a readily accessible position at least one fire extinguisher which must be of -

- (a) the dry powder type with a capacity of at least two-and-a-half kilogram; or

[The singular word “kilogram” should be plural to be grammatically correct.]

- (b) the halogenated hydrocarbon type (BCF) with a capacity of at least one kilogram,

and which must be in good working order.

Rear-view mirrors

280. In addition to the rear-view mirror prescribed for motor vehicles in regulation 223, every bus operating for reward must be fitted with a rear-view mirror that must enable the driver of the bus, when he or she is in the driving position, to see a reflection of every entrance and exit of the bus.

Tilt angle

281. (1) A person may not operate a double-decker bus on a public road unless the bus is capable of being tilted sideways to an angle of at least 23 degrees in either direction from the upright position without overturning while -

- (a) every seat on the upper deck of the bus carries a mass of 63 kilograms;
- (b) an additional mass of 63 kilograms is placed on the upper deck of the bus to represent a conductor;
- (c) the goods compartment on the upper deck of the bus, if any, is loaded to capacity;
- (d) except for a mass of 63 kilograms on the driver’s seat, the lower deck of the bus is empty; and

REGULATIONS
Road Traffic and Transport Act 22 of 1999
Road Traffic and Transport Regulations, 2001

(e) the bus is ready to be driven on a road, except for an empty fuel tank.

(2) For the purposes of issuing any roadworthy certificate in respect of a double-decker bus, a vehicle examiner may demand the production of a manufacturer's certificate or other similar certificate that certifies that the bus complies with subregulation (1).

Standing persons

282. (1) A person may not operate, on a public road, a bus in which a person is permitted to stand, except when entering or leaving such bus -

- (a) on any upper deck, steps, stairs or open platform;
- (b) in the cross passageway referred to in regulation 274; or
- (c) in any area with a roof height of less than one comma seven metres.

(2) The maximum number of standing persons that may be carried in a bus must be calculated in accordance with the formula -

$$\frac{A-B}{C}$$

in which formula -

- (a) "A" represents the total clear floor space in square metres of the bus;
- (b) "B" represents the total clear floor space in square metres of the places referred to in subregulation (1); and
- (c) "C" represents the figure zero comma one two five, being the clear floor space in square metres which must be available for each standing person.

(3) A bus carrying standing persons must be equipped with sufficient hand straps, handrails or grab handles for all standing persons.

(4) A person may not operate on a public road, a minibus in which a person is permitted to stand for reward, except if the minibus complies with the requirements of subregulations (1), (2) and (3), which apply with the necessary changes.

Special provisions relating to school buses

283. Despite regulations 251, 252, 271 and 275, in the case of a school bus registered prior to 1 April 1991 -

- (a) the number of persons permitted on any seat must be determined at the rate of 330 millimetres per person, measured at the widest part of the seat with the doors closed, but regulation 250 does not apply;
- (b) a seat must -
 - (i) have a backrest -

REGULATIONS
Road Traffic and Transport Act 22 of 1999
Road Traffic and Transport Regulations, 2001

- (aa) of which the top must be at least 300 millimetres from seat level; and
- (bb) of which the bottom must be not more than 75 millimetres from seat level;
- (ii) be of a height, from the floor or footrest of the seat to the seat level, of at least 300 millimetres and not more than 460 millimetres;
- (iii) have a depth, from the front of the seat to the front of the backrest thereof, of at least 300 millimetres;
- (iv) have a width in accordance with paragraph (a);
- (v) where the seat faces in the same direction as another seat, have a horizontal distance at seat level, between the front of the backrest of the seat and the back of the backrest of the seat in front of the first-mentioned seat, of at least 530 millimetres;
- (vi) where the seat faces a partition or similar obstruction, have a horizontal distance at seat level, between the front of the backrest of the seat and the partition or obstruction, of at least 530 millimetres; and
- (vii) where the seat faces another seat, have a horizontal distance at seat level, between the front of the backrest of the seat, of at least one comma zero six metres; and
- (c) for the purpose of determining the number of persons who may be carried on the bus, the mass of a person together with his or her personal effects must be taken as 45 kilograms.

CHAPTER 6
MATTERS RELATING TO THE FITNESS OF OPERATORS

PART 1
OPERATOR REGISTRATION

Classes of motor vehicles in respect of which operator must be identified and registered

- 284.** (1) An operator must be identified and registered in respect of -
- (a) a goods vehicle with a gross vehicle mass exceeding 3 500 kilograms;
 - (b) a breakdown vehicle;
 - (c) a bus;
 - (d) a minibus -
 - (i) with a gross vehicle mass exceeding 3 500 kilograms; or
 - (ii) which is designed or adapted to convey 12 or more persons including the driver;

REGULATIONS
Road Traffic and Transport Act 22 of 1999
Road Traffic and Transport Regulations, 2001

- (e) any other motor vehicle used to convey persons for reward; or
 - (f) a motor vehicle contemplated in Part 4 of this Chapter.
- (2) Subregulation (1) does not apply to a motor vehicle referred to in subregulation (1) that is -
- (a) operated on a public road under the authority of a temporary or special permit, or motor trade number, as the case may be;
 - (b) not operated on a public road and for the purpose of this paragraph, the words “operated on a public road” may not be construed to include the presence of the motor vehicle on a public road for the purpose of -
 - (i) being driven to the premises of the owner in order to take delivery thereof; or
 - (ii) crossing a public road from one premises of the owner to another;
 - (c) a trailer drawn by a tractor; or
 - (d) a motor vehicle referred to in paragraphs (c), (d) and (e) of subregulation (1), if the operator of that motor vehicle is the holder of a temporary permit issued in terms of the Road Transportation Act, 1977 (Act No. 74 of 1977).

[subregulation (2) amended by GN 205/2004]

Categories of operator cards

285. (1) An operator card must be issued for a goods vehicle category, passenger vehicle category or dangerous goods vehicle category.

- (2) An operator card for the -
 - (a) goods vehicle category must be marked with the letter “G”;
 - (b) passenger vehicle category, must be marked with the letter “P”; and
 - (c) dangerous goods vehicle category, must be marked with the letter “D”.

(3) An operator card authorises the holder thereof to operate the motor vehicle to which that operator card relates on a public road.

Manner of registration of operator and issuing of operator card

286. (1) The registering authority concerned must register the owner of a motor vehicle contemplated in regulation 284 as operator of that motor vehicle on application for the licensing of the motor vehicle and must -

- (a) satisfy itself that the information provided is complete and correct;
- (b) satisfy itself that an operator card issued to the designated person, is not suspended in terms of section 65 of the Act;

REGULATIONS
Road Traffic and Transport Act 22 of 1999
Road Traffic and Transport Regulations, 2001

- (c) satisfy itself in accordance with guidelines set by the Minister, that the offence record of the applicant is satisfactory; and
- (d) if applicable, retain a copy of the notice in respect of operator identification.

(2) The owner of a motor vehicle must, if applicable, notify the registering authority of the identity of the person to be registered as the operator as contemplated in section 60 (5) of the Act, on the approved form and the appropriate fee contemplated in Schedule 1 must accompany the notification.

(3) The registering authority must on receipt of the identification referred to in subregulation (2) and the appropriate fee contemplated in Schedule 1, register that person as the operator of the motor vehicle concerned in accordance with subregulation (1), on condition that such person complies with section 60 (4) of the Act.

- (4) (a) If the registering authority is satisfied in terms of subregulation (1) or (3), it must -
 - (i) record the particulars of the operator in the register of operators referred to in regulation 366(6)(b);
 - (ii) issue an operator card on the approved form, in respect of each operator registered in terms of subparagraph (i); and
 - (iii) forward the operator card to the person registered as such.
- (b) If the registering authority is not satisfied in terms of subregulation (1) or (3), it must notify the owner or the identified person on the approved form.

(5) The counterfoil of the operator card must be kept at the business address of the operator.

Application for and issue of duplicate operator card

287. (1) A duplicate operator card may only be issued to an operator who is not also the owner of the motor vehicle concerned and if the operator card is stolen or destroyed.

(2) An application for a duplicate operator card must be made to the registering authority, on the approved form, and must be accompanied by -

- (a) the appropriate fee for a duplicate operator card as contemplated in Schedule 1;
- (b) acceptable identification of the operator or proxy of the operator; and
- (c) the counterfoil of the original operator card or a declaration in respect of the original operator card.

(3) Upon receipt of the application referred to in subregulation (1) the registering authority must satisfy itself that the operator is registered in respect of the vehicle concerned and if so satisfied must issue a duplicate operator card to the applicant.

REGULATIONS
Road Traffic and Transport Act 22 of 1999
Road Traffic and Transport Regulations, 2001

(4) For the period between the application in terms of this regulation and the receipt of the duplicate operator card by the applicant the counterfoil of the original operator card referred to in regulation 286(5) is deemed to be the duplicate operator card and a copy of the counterfoil must be kept in the motor vehicle concerned.

Change of particulars

288. (1) The registering authority must, upon receipt of a notice in terms of section 64(g) of the Act, update the register of operators accordingly.

(2) If a new operator card is required, that card may be issued subject to subregulation (3), upon payment of the appropriate fee contemplated in Schedule 1.

(3) If a new operator card is required due to the change of address of the operator or to the change of the allocated licence number of the motor vehicles or motor vehicle of an operator under regulation 35, that card may be issued upon payment of the appropriate fee contemplated in Schedule 1.

Procedure in case of suspension

289. (1) If the Minister suspends an operator in terms of section 65 of the Act, he or she must -

- (a) notify the operator concerned on the approved form;
- (b) require a traffic officer or an inspector of licences to locate and inspect the motor vehicle concerned to ensure that the operator card has been removed; and
- (c) notify the registering authority concerned.

(2) The operator must, on receipt of a notice of suspension in terms of section 65 of the Act, immediately return the operator card and counterfoil of that card within seven days to the registering authority.

(3) The registering authority must, after receipt of the operator card and counterfoil referred to in subregulation (2), keep that operator card and counterfoil in the manner and for the period as determined by the Minister.

Manner in which operator card is to be displayed on motor vehicle

290. An operator card issued in terms of regulation 286 in respect of a motor vehicle must be displayed -

- (a) if the motor vehicle is fitted with a transparent windscreen, by affixing it in an upright position on the inside of the windscreen in such manner that the print on the face of the operator card is clearly legible from the outside to a person standing in front or to the left front of such motor vehicle; or
- (b) if the motor vehicle is not fitted with a transparent windscreen, by affixing it -
 - (i) in a conspicuous position on the left front side of the vehicle in such manner that the print on the face of it is clearly legible from that side; and

REGULATIONS
Road Traffic and Transport Act 22 of 1999
Road Traffic and Transport Regulations, 2001

- (ii) if it is exposed to the weather, on the inside of the transparent front of a durable watertight holder.

Power of Minister

291. (1) The registering authority may, if it has reason to believe that any information submitted by the owner or designated person is false, refer the application to the Minister for consideration.

(2) The Minister may, on consideration of the information request the owner or designated person to appear before him or her.

(3) The Minister must decide within a period of 7 days whether the person concerned may be registered as an operator or not, and must inform the registering authority accordingly.

(4) The registering authority must implement the decision of the Minister.

PART 2
DRIVING HOURS

[This Part of the regulations is not yet in force.]

Drivers to comply with driving hours

292. (1) Subject to regulation 299, a driver of a motor vehicle of a class referred to in regulation 284 (1)(a), (b), (c) and (f), may not drive that motor vehicle on a public road for a period of time exceeding the limits referred to in regulation 293.

(2) An operator or person exercising control over a driver of a motor vehicle of a class referred to in regulation 284 (1), may not permit, induce, force or in any other way influence that driver to contravene the provisions of subregulation (1).

Time limits

293. (1) If a driver of a motor vehicle referred to in regulation 292 (1) is not accompanied by another driver licensed to drive that motor vehicle, he or she may only drive that vehicle for a -

(a) maximum of five hours continuously; and

(b) maximum of 14 hours in a 24 hour period.

(2) A driver of a motor vehicle referred to in regulation 292(1) must rest for -

(a) a minimum of 15 minutes at any one time;

(b) a minimum of 30 minutes accumulated during a period of five hours and 30 minutes; and

(c) a minimum continuous period of nine hours in a 24 hour period.

(3) If a driver of a motor vehicle referred to in regulation 292(1) is accompanied by another driver who is licensed to drive that motor vehicle, and that other driver alternatively

REGULATIONS
Road Traffic and Transport Act 22 of 1999
Road Traffic and Transport Regulations, 2001

drives the motor vehicle, the driving time limits and resting time limits referred to in subregulations (1) and (2) apply, except for subregulation 2(c).

(4) A driver, who drives a motor vehicle for a 14 hour period, as referred to in subregulation (1)(b), may not drive a motor vehicle referred to in regulation 292(1), alternatively subject to subregulation (2), for a continuous period of 30 hours.

(5) A driver who drives a motor vehicle referred to in regulation 292(1) alternatively as contemplated in subregulation (4), for a period exceeding 15 hours but less than 20 hours, must thereafter rest for at least 10 hours.

(6) A driver who drives a motor vehicle referred to in regulation 292(1) alternatively as contemplated in subregulation (4), for a period exceeding 20 hours, must thereafter rest for at least 12 hours.

Recording device to measure driving time

294. (1) A person may not operate a motor vehicle referred to in regulation 292(1) on a public road, unless the motor vehicle is fitted with an approved automatic, electronic, electrical or mechanical recording device capable of providing a record of the information required in terms of regulation 295, and in the case of a combination of motor vehicles, this regulation only applies to the drawing vehicle.

(2) The driver of a motor vehicle referred to in regulation 292(1) must, when driving that motor vehicle on a public road, use the recording device in the manner contemplated in regulation 295.

(3) Notwithstanding subregulation (1), (2) and regulation 296, the Minister may direct that the record referred to in regulation 295 may manually be recorded on an approved form.

Use of recording device

295. The driver of a motor vehicle referred to in regulation 292(1) must -

- (a) use the recording device fitted to the motor vehicle to provide a continuous record, in duplicate, of that driver's driving times and resting times;
- (b) have in his or her possession a record of the times referred to in paragraph (a) in respect of the previous 48 hours; and
- (c) as soon as possible after the period contemplated in paragraph (b), deliver to the operator registered in respect of the motor vehicle concerned, the record referred to in paragraph (a) pertaining to the times that the driver was driving the motor vehicle concerned.

Duties of operator with regard to maintenance and preservation of record produced by recording device

296. (1) Subject to regulation 294(3), the operator of a motor vehicle referred to in regulation 292(1) must -

- (a) fit a recording device contemplated in regulation 294 to the motor vehicle in the manner determined by the Minister; and

REGULATIONS
Road Traffic and Transport Act 22 of 1999
Road Traffic and Transport Regulations, 2001

(b) retain the completed records referred to in regulation 295 for a period of three years.

(2) Subject to regulation 294(3), the operator of a motor vehicle referred to in regulation 292(1) must, once every two years, submit the device referred to in regulation 294 for calibration at an approved centre.

Records

297. (1) If a motor vehicle referred to in regulation 292(1) is involved in an accident, a traffic officer may remove and analyse or cause to be analysed, the records of the recording device fitted to that motor vehicle or the record kept on the approved form.

(2) A person may not falsify the record of the recording device or record false information on the approved form referred to in regulation 294(3).

Presumption

298. Where in any prosecution for an alleged contravention of this Part, evidence to prove that contravention is given of driving hours ascertained by means of the analysing of the records of the recording device, the recording device itself or the approved form referred to in regulation 294(3), those driving hours are deemed to be correct in the absence of any evidence to the contrary, provided that a certificate of calibration obtained in terms of regulation 296(2) or by an authorised official in terms of regulation 297(1), is produced.

[The word “analysing” is misspelt in the *Government Gazette*, as reproduced above.]

Exemptions

299. The Minister may exempt certain categories of motor vehicles from this Part by notice in the *Gazette*.

PART 3
CROSS-BORDER ROAD TRANSPORTATION

Manner of application for cross-border permit

300. An application in terms of section 71 of the Act must be made to the Minister on the approved form, and must be accompanied by -

- (a) acceptable identification of the applicant;
- (b) a certified copy of the registration certificate of the motor vehicle with which the cross-border road transport is to be undertaken;
- (c) the fee prescribed in terms of section 18 of the Road Fund Administration Act, 1999;
- (d) a document attesting to the roadworthiness of the motor vehicle referred to in paragraph (b); and
- (e) any other documentation required by the Permanent Secretary.

REGULATIONS
Road Traffic and Transport Act 22 of 1999
Road Traffic and Transport Regulations, 2001

Manner of issue of cross-border permit

- 301.** (1) The Minister must, on receipt of the application referred to in regulation 300 -
- (a) satisfy himself or herself that the information provided in terms of regulation 300 is complete and correct;
 - (b) satisfy himself or herself that the offences record of the applicant is satisfactory; and
 - (c) retain a copy of the application concerned.
- (2) (a) If the Minister is satisfied in terms of subregulation (1), he or she may, on any conditions as he or she considers necessary, issue a cross-border permit to the applicant on the approved form in respect of each motor vehicle concerned.
- (b) If the Minister is not satisfied in terms of subregulation (1), he or she must notify the applicant accordingly.
- (3) The cross-border permit issued in terms of subregulation (2) must at all times be kept in the motor vehicle to which that permit relates.

Period of validity of cross-border permit

302. A cross-border permit issued in terms of regulation 301 is valid for a maximum period of three months.

Application for and issue of duplicate cross-border permit

303. (1) An application for a duplicate cross-border permit must be made to the Minister on the approved form, and must be accompanied by -

- (a) the fee prescribed in terms of section 18 of the Road Fund Administration Act, 1999, for the duplicate permit;
 - (b) acceptable identification of the signee thereof; and
 - (c) the counterfoil of the original permit or a declaration in respect of that original permit.
- (2) On receipt of the application referred to in subregulation (1) the Minister must satisfy himself or herself that a cross-border permit issued in terms of regulation 301 has been issued in respect of the motor vehicle concerned and must issue a duplicate of that permit to the applicant.
- (3) For the period between the application in terms of this regulation and the receipt of a duplicate cross-border road transport permit by the applicant, the counterfoil of the original cross-border road transport permit is deemed to be that duplicate cross-border road transport permit and a copy of that counterfoil must be kept in the motor vehicle concerned.

REGULATIONS
Road Traffic and Transport Act 22 of 1999
Road Traffic and Transport Regulations, 2001

Definitions for dangerous goods

304. For the purposes of this Part -

“competent authority” means any competent authority determined by the Minister by notice in the *Gazette*;

“consignor” means the person who offers dangerous goods for transport in a vehicle referred to in regulation 305(1), and includes the manufacturer or his or her agent, duly appointed as such;

“consignee” means the person who accepts dangerous goods which have been transported in a vehicle referred to in regulation 305(1);

“dangerous goods inspector” means a person appointed as a traffic officer or a road transport inspector and who has been trained to enforce these regulations;

“exempt quantities” means those quantities referred to in Annex C to code of practice SABS 0232-1 defined in this regulation under “Standard Specification”;

“incident” means an unplanned event during the transportation or storage of dangerous goods which involves leakage or spillage of dangerous goods or risk thereof;

“multi-load” means more than one type or hazard class of dangerous goods or substances carried together;

“premises” means land or any building or other structure and includes any train, boat, ship, aircraft or other vehicle;

“qualified person” means a person trained to perform any specific task, nominated by the operator, consignor or consignee under regulation 308; and

“Standard Specifications” means the standard specifications of the South African Bureau of Standards -

- (a) SABS 1398 “Road tank vehicles for petroleum-based flammable liquids” published by the South African Government Notice No. R. 1851 of 1 December 1995;
- (b) SABS 1518 “Transportation of dangerous goods - design requirements for road tankers” published by the South African Government Notice Nos. R.101 of 1 August 1997, R.411 of 27 March 1998 and R.225 of 17 March 2000;
- (c) SABS 0228 “The identification and classification of dangerous substances and goods” published by the South African Government Notice No. R. 841 of 24 May 1996;
- (d) SABS 0229 “Packaging of dangerous goods for road and rail transportation in South Africa” published by the South African Government Notice No. R.435 of 20 March 1997;
- (e) SABS 0230 “Transportation of dangerous goods - Inspection requirements for road vehicles” published by the South African Government Notice No. R.3160 of 20 November 1992;

REGULATIONS
Road Traffic and Transport Act 22 of 1999
Road Traffic and Transport Regulations, 2001

- (f) SABS 0231 “Transportation of dangerous goods-Operational requirements for road vehicles” published by the South African Government Notice No. R. 718 of 30 May 1997;
- (g) SABS 0232-1 “Transportation of dangerous goods Emergency information systems, Part I: Emergency information system for road transportation” published by the South African Government Notices Nos. R. 841 of 24 May 1996 and R. 2137 of 27 December 1992;
- (h) SABS 0232-3 “Transportation of dangerous goods-Emergency information systems, Part 3: Emergency action codes” published by the South African Government Notice No. R.225 of 17 March 2000; and
- (i) SABS 0233 “Intermediate bulk containers for dangerous substances” published by the South African Government Notice No. R.1502 of 5 June 1992, and the standard specifications are incorporated into these regulations;

“**Tremcard**” means the transport emergency card, listing the hazards and emergency information for a material being transported, for use by the driver during an incident, or by the emergency services, if required.

Application

305. (1) Subject to subregulation (2), this Part applies to all vehicles registered in Namibia, wherever they may be, and to all vehicles other than those registered in Namibia, whenever they are within Namibia, in or on which dangerous goods are transported, and to such dangerous goods.

(2) These regulations do not apply to dangerous goods that are transported in quantities that do not exceed the exempt quantities.

Limitation on transportation of dangerous goods

306. (1) A person may not transport or cause to be transported dangerous goods that may, in terms of the Standard Specification, not be transported.

(2) Dangerous goods, other than the dangerous goods referred to in subregulation (1), may not be transported unless in accordance with this Part.

(3) Any person who transports or causes the transportation of dangerous goods in contravention of this Part is guilty of an offence.

Exemptions

307. The Permanent Secretary may, after consultation with the competent authority concerned, either generally or subject to such conditions as he or she considers necessary, by way of notice in the *Gazette*, grant exemption in respect of a specific consignment of dangerous goods to be transported by any vehicle, or class or description of vehicle, from any of or all the provisions of these regulations, and may, subject to giving reasonable notice, amend or cancel any exemption so granted.

Duties of operator, driver, consignor and consignee

REGULATIONS
Road Traffic and Transport Act 22 of 1999
Road Traffic and Transport Regulations, 2001

308. (1) The duties of the operator, driver, consignor and consignee with regard to the transportation of dangerous goods by road are as prescribed in the standard specifications, and any other legislation applicable to the transportation of dangerous goods.

(2) The operator, consignor or consignee must nominate a qualified person to perform such tasks with respect to the transportation of dangerous goods as are prescribed to be so performed in the standard specifications.

(3) Subject to subregulation (2), the operator, consignor and consignee may nominate a qualified person for any purpose considered necessary by that operator, consignor and consignee with relation to the transportation of dangerous goods.

Dangerous goods to be compatible

309. The operator must ensure that a multi-load of dangerous goods transported on a vehicle is compatible as prescribed in Annex D to code of practice SABS 0232-1.

Authority for classification of dangerous goods

310. If there is any doubt as to the appropriate classification of dangerous goods, such dangerous goods must be classified by an approved authority, in accordance with code of practice SABS 0228.

Driver to undergo training

311. (1) For the purposes of this regulation, the word “driver” means any person who drives or attempts to drive a vehicle with a gross vehicle mass exceeding 3 500 kilograms or a vehicle to which SABS 1398 or SABS 1518 apply.

(2) An operator must ensure that the drivers of the vehicles in his or her charge referred to in regulation 305(1), undergoes training every twelve months at an approved institution.

[The verb “undergoes” should be “undergo” to accord with the subject “drivers”.]

(3) Each approved institution must submit a syllabus for the training of the drivers referred to in subregulation (1) to the Minister for approval, 30 days before training commences at those institutions for a particular year.

(4) The syllabus for the training of drivers must contain at least -

- (a) the interpretation and implementation of the instructions on the Tremcard;
- (b) theoretical and practical training relevant to the type of vehicle and class of dangerous goods to be assigned to the driver concerned;
- (c) detailed instruction on the procedures in place for the specific kind of dangerous goods to be transported by the driver concerned and practical training on the emergency action to be taken for the various incidents which may occur with regard to the dangerous goods concerned;

REGULATIONS
Road Traffic and Transport Act 22 of 1999
Road Traffic and Transport Regulations, 2001

- (d) duties of the driver before proceeding on a route concerning, amongst others, the condition of the vehicle, the documents to be kept in the vehicle, instructions regarding the route to be taken, warning signs and warning devices to be displayed or stored in the vehicle, the correct type and number of fire extinguishers to be fitted to the vehicle and protective clothing to be used;
- (e) behaviour expected of the driver on the route, amongst others, planning of stops for deliveries or checking of the tyres and vehicle, procedure to be followed in the event of stops, periods of driving allowed and action to be taken in the event of an incident occurring; and
- (f) procedure to be followed by the driver on reaching his or her destination.

(5) An approved institution must issue drivers with a certificate on successful completion of training.

Documents to be held by driver

312. (1) The driver of a vehicle referred to in regulation 305(1) shall ensure that such Tremcards and manifests as are required in terms of the standard specification, and which pertain to the dangerous goods carried on the vehicle are held in the designated space in the cab of that vehicle at such time as dangerous goods are being transported in that vehicle.

- (2) The driver of a vehicle referred to in regulation 305(1) must produce on demand -
 - (a) a valid medical certificate prescribed in the standard specification;
 - (b) his or her driving licence endorsed to authorise the transportation of dangerous goods;
 - (c) the certificate issued to him or her by an approved institution under regulation 311 (5);
 - (d) a document containing a clear indication of the route to be followed by the vehicle, planned in accordance with code of practice SABS 0231; and
 - (e) the documents referred to in subregulation (1), whenever he or she is operating a vehicle referred to in regulation 305(1).

Dangerous goods inspectors

313. A certificate of appointment must be issued to a dangerous goods inspector on his or her appointment under the Act which must reflect the designation, the conditions under and the classes of dangerous goods in respect of which he or she has been appointed, and, with reference to any provision of regulation 314, the powers to be exercised by him or her.

Powers, duties and functions of dangerous goods inspectors

314. (1) A dangerous goods inspector may stop and enter any motor vehicle on or in which any substance suspected to be dangerous goods is or is suspected to be transported, or enter any premises on or in which any other operation or activity relating to such transport with or in connection with any such substance is or is suspected to be carried out, and may, subject to the Act -

REGULATIONS
Road Traffic and Transport Act 22 of 1999
Road Traffic and Transport Regulations, 2001

- (a) inspect or search the vehicle or premises, or examine, or extract, take and remove samples of, or direct an approved authority to examine, extract or remove, any substance, found in or upon such vehicle or premises, or any packaging, receptacles, unit loads, bulk containers and bulk transportation equipment or other objects so found which is or is suspected to be used, or destined or intended for use, for, in or in connection with the transport of dangerous goods, or for, or in connection with any other operation or activity with or in connection with the transport of dangerous goods, or open or direct an approved authority to open any packaging, receptacles, unit loads, bulk containers and bulk transportation equipment suspected to contain such dangerous goods;
- (b) detain a vehicle which is on reasonable grounds suspected of contravening these regulations, for the purposes of exercising any of the powers of a dangerous goods inspector under this regulation;
- (c) demand from the driver, operator or any person in charge of the vehicle or premises, to produce any document prescribed under these regulations;
- (d) demand any information regarding any substance or packaging, receptacles, unit loads, bulk containers, bulk transportation equipment or other objects from any person in whose possession or charge it is or from the operator or person in charge of the vehicle or premises;
- (e) weigh, count, measure, mark or seal, or direct an approved authority to weigh, count, measure, mark or seal, any substance or packaging, receptacles, unit loads, bulk containers, bulk transportation equipment or other objects or lock, secure, seal or close any door or opening giving access to it;
- (f) examine or make copies of, or take extracts from, any book, statement or document found in or on the vehicle or premises and which refers or is suspected to refer to the substance, packaging, receptacles, unit loads, bulk containers, bulk transportation equipment or other objects;
- (g) demand from the operator or any person in charge of the vehicle or premises or from any person in whose possession or charge such book, statement or document referred to in paragraph (f) is, an explanation of any entry therein;
- (h) inspect any operation or process carried out, in or upon the vehicle or premises in connection with any activity referred to in paragraph (a);
- (i) demand any information regarding the operation or process referred to in paragraph (h) from the operator or person in charge of the vehicle or premises or from any person carrying out or in charge of the carrying out of such operation or process;
- (j) seize any substance, book, statement or document or other packaging, receptacles, unit loads, bulk containers, bulk transportation equipment or other objects which appears to provide proof of a contravention of any provision of this Act.

[The verb “appears” should be “appear” to accord with the subject “objects”.]

REGULATIONS
Road Traffic and Transport Act 22 of 1999
Road Traffic and Transport Regulations, 2001

(2) If a dangerous goods inspector intends to exercise or perform any power, duty or function under these regulations in the presence of any persons affected thereby, he or she must on demand exhibit the appointment certificate issued to him or her under regulation 313.

(3) Despite the provisions of this regulation, dangerous goods may not be unloaded or decanted, or dangerous goods packages may not be opened, unless -

- (a) the operator was duly notified;
- (b) such unloading, decanting or opening of packages is authorised by the local authority concerned; and
- (c) a qualified person supervises the unloading, decanting or opening of packages.

CHAPTER 7
ROAD TRAFFIC SIGNS AND SPEED LIMITS

PART 1
ROAD TRAFFIC SIGNS

Purpose, classification and types of road traffic signs

315. (1) A road traffic sign has one of the following purposes:

- (a) Regulatory, that is a road traffic sign which directs a road user to take or not to take specific action;
- (b) warning, that is a road traffic sign calling attention to conditions on a public road which are dangerous or potentially dangerous to road users;
- (c) guidance or information, that is a road traffic sign indicating a destination, direction, distance, amenity, facility, place of interest, tourist attraction or location, or any combination of these, or a road traffic sign which imparts general information or advice to road users.

(2) Road traffic signs are divided as follows:

- (a) Class I: Road signs -
 - (i) regulatory signs -
 - (aa) control signs;
 - (bb) command signs;
 - (cc) prohibition signs;
 - (dd) reservation signs;
 - (ee) comprehensive signs;
 - (ff) exclusive secondary signs;

REGULATIONS
Road Traffic and Transport Act 22 of 1999
Road Traffic and Transport Regulations, 2001

- (gg) derestriction signs;
- (ii) warning signs -
 - (aa) advance warning signs -
 - (aaa) road layout signs;
 - (bbb) direction of movement signs;
 - (ccc) symbolic signs;
 - (bb) hazard marker warning signs;
- (iii) guidance signs -
 - (aa) location signs;
 - (bb) route marker signs;
 - (cc) direction signs;
 - (dd) freeway direction signs;
 - (ee) tourism signs;
 - (ff) diagrammatic signs;
 - (gg) local direction signs;
 - (hh) toll direction signs;
- (iv) information signs;
- (b) Class II: Road markings -
 - (i) regulatory markings -
 - (aa) transverse regulatory markings; (bb) longitudinal regulatory markings;
 - (ii) warning markings;
 - (iii) guidance markings;
- (c) Class III: Road signals -
 - (i) regulatory signals -
 - (aa) traffic signals -
 - (aaa) vehicular light signals;
 - (bbb) pedestrian light signals;

REGULATIONS
Road Traffic and Transport Act 22 of 1999
Road Traffic and Transport Regulations, 2001

- (ccc) pedal cycle light signals;
- (bb) red flashing signal;
- (cc) overhead lane direction control signals;
- (dd) other regulatory signals;
- (ii) warning signals -
 - (aa) warning flashing signals;
 - (bb) warning flag signals.

(3) A regulatory, warning, guidance or information road traffic sign for which a temporary sign number is allocated may be used in the temporary sign colours as prescribed by regulation 317(1)(b), but this provision does not apply to any control regulatory sign, location guidance sign or tourism guidance sign.

- (4) (a) If no specific symbol is available for the regulatory or warning message required, a word message may be used on the background of a regulatory or warning sign of standard shape, size and colour, and the letters used must be black semi-matt on a white or yellow background and white on a blue background.
- (b) The lettering must substantially conform to one of the standard letter styles detailed in an approved road traffic signs manual and must be of a maximum size permitted by the space available and the message to be displayed, but may not be less than 70 millimetres in height.

Dimensions for manufacture of road traffic signs

316. (1) (a) The minimum external dimensions in millimetres of regulatory and warning signs are given in relation to the speed limit in kilometres per hour pertaining to the section of public road on which the signs are erected, but a tolerance not exceeding five percent below such minimum dimension is permissible.

- (b) The minimum dimensions and speed referred to in subregulation (1) is, subject to paragraph (c) -

[The verb “is” should be “are” to accord with the subject “dimensions and speed”.]

- (i) for circular regulatory signs as shown in the table below:

SIGN TYPE					
Speed limit		0 - 60	61 - 80	81 - 100	101 - 102 [possibly intended to be 101-120]
Diameter	General	600	900	1 200	1 200
	Overhead	900	1 200	1 200	1 600
	Parking and stopping	450	900	1 200	1 200

REGULATIONS
Road Traffic and Transport Act 22 of 1999
Road Traffic and Transport Regulations, 2001

but -

- (aa) a stop sign must be the same size as a circular sign except for a sign used by a scholar patrol which may be a minimum of 450 millimetres in diameter;
 - (bb) a sign for pedestrians and cyclists may be a minimum of 300 millimetres in diameter; and
 - (cc) a keep left sign used on the vertical face of a bollard may be a minimum of 300 millimetres in diameter;
- (ii) for triangular regulatory and warning signs as shown in the table below:

Speed limit	0 - 60	61 - 80	81 - 100	101 - 120
Speed limit	900	1 200	1 200	1 500

(iii) for rectangular regulatory signs as shown in the table below:

SIGN TYPE					
Speed limit		0 - 60	61 - 80	81 - 100	101 - 102 [possibly intended to be 101-120]
Height x width	General	600 x 450	900 x 675	1 200 x 900	1 200 x 900
	Overhead	900 x 675	1 200 x 900	1 200 x 900	1 600 x 1 200
	Parking and stopping	445 x 338	900 x 675	1 200 x 900	1 200 x 900
	Bus and minibus stop	450 x 225	600 x 300	800 x 400	900 x 450

but a one way roadway sign must be of a minimum height of 450 millimetres and a minimum width of 600 millimetres.

- (c) The following signs must have the following minimum dimensions:
- (i) The part of signs R1.3 and R1.4 containing the number must be the same size as one side of stop sign R1.
 - (ii) The lower part of sign R2.1 must be as shown in the table below:

Speed limit	0 - 60	61 - 80	81 - 100	101 - 120
Height x width	300 x 225	450 x 338	600 x 450	750 x 563

- (iii) Sign R5 must have a minimum side length of 450 millimetres.
- (iv) An exclusive secondary message sign must be the same length as the diameter or width of the upper sign in the sign combination.

REGULATIONS
Road Traffic and Transport Act 22 of 1999
Road Traffic and Transport Regulations, 2001

- (v) Signs W401, W402 and W415 must have the minimum dimensions as shown in the table below:

Speed limit	0 - 60	61 - 80	81 - 100	101 - 120
Height x width	600 x 150	600 x 150	800 x 200	800 x 200

- (vi) Signs W403 and W404 must have the minimum dimensions as shown in the table below:

Speed limit	0 - 60	61 - 80	81 - 100	101 - 120
Diagonal	1 015	1 200	1 200	1 500

- (vii) Signs W405 to W410 and W414 must have the minimum dimensions as shown in the table below:

Speed limit	0 - 60	61 - 80	81 - 100	101 - 120
Height	450	450	600	600

but sign W414 must have a minimum height of 600 millimetre and a height of 1600 millimetre, irrespective of the speed limit when used in conjunction with sign GA4;

[The word “millimetre” appears twice in the singular in subparagraph (vii) and should be plural in both instances to be grammatically correct.]

- (viii) Sign W411 must have the minimum dimensions as shown in the table below:

Speed limit	0 - 60	61 - 80	81 - 100	101 - 120
Height x width	200 x 1 200	300 x 1 800	400 x 2 400	400 x 2 400

- (ix) Sign TW412 must have the minimum dimensions as shown in the table below:

Speed limit	0 - 60	61 - 80	81 - 100
Height x width	450 x 900	600 x 1 200	600 x 1 200

- (x) sign W413 must have the minimum dimensions as shown in the table below:

Speed limit	0 - 60	61 - 80	81 - 100	101 - 120
Height x width	600 x 350	600 x 350	800 x 466	800 x 466

- (2) (a) The minimum width of a longitudinal road marking must be 100 millimetres, but a tolerance not exceeding 10 percent below such minimum dimension is permissible.

REGULATIONS
Road Traffic and Transport Act 22 of 1999
Road Traffic and Transport Regulations, 2001

- (b) The minimum length of a continuous longitudinal road marking module must be nine metres on a public road in an urban area and 12 metres on any other public road, but this provision does not apply to such marking used to mark the edge of a painted island.
- (c) The minimum width of a transverse road marking must be -
 - (i) for road marking RTM1 in an urban area, 300 millimetres and in any other area, 500 millimetres;
 - (ii) for road marking RTM2 in an urban area, 200 millimetres and in any other area, 300 millimetres;
 - (iii) for road marking RTM4, 2 400 millimetres;
 - (iv) for road marking GM5, 300 millimetres; or
 - (v) for any other transverse road marking, 100 millimetres.

(3) The minimum diameter of any disc light signal of a traffic signal must be 210 millimetres, but a tolerance not exceeding 10 percent below such minimum dimension is permissible.

(4) The specific dimensions of a road traffic sign and of the letter styles and symbols used on such sign must conform substantially with the requirements laid down in an approved road traffic signs manual.

Colours for manufacture of road traffic signs

- 317.** (1) (a) The colours of a road traffic sign must be as indicated in Schedule 2.
- (b) Where a temporary version of a road sign is provided for by means of a temporary number allocated to that sign, the colour of that sign must be, unless otherwise indicated in Schedule 2, altered so that -
- (i) a white symbol, letter or border becomes black semi-matt and any superimposed black symbol becomes white retro-reflective;
 - (ii) the yellow symbol on signs R302 and R303 and any yellow letters, numerals or punctuation marks become black semi-matt;
 - (iii) a white, blue or green background becomes yellow retro-reflective,
- but -
- (aa) a red border or other areas remain red except that -
 - (aaa) the border of a temporary diagrammatic sign or high visibility sign becomes black semi-matt;
 - (bbb) the red areas on signs W401, W402, W405 to W410 and W414 become black semi-matt;

REGULATIONS
Road Traffic and Transport Act 22 of 1999
Road Traffic and Transport Regulations, 2001

- (bb) the superimposed coloured portions of symbols on signs R126, R232, R316, R321, R322 (Nam), R316P, R321P, R322P (Nam), W301, W302 and W303 remain as they are;
 - (cc) any other yellow symbol remains yellow but is surrounded by a thin black semi-matt border.
- (c) Where only a temporary version of a road sign is provided for, it must conform to the temporary colours referred to in paragraph (b).
- (2) Where a road traffic sign is required to be any specific colour or colours, those colours must conform to the following specifications published by the South African Bureau of Standards:
- (a) For red, orange, yellow, green, blue, purple, white and brown retro-reflective material and for red, orange, yellow, green, blue, purple, white, grey, black and brown paint, the coefficient of retro-reflection, the colour, luminance factor and specular gloss, as the case may be, prior to weathering contemplated in the Standard Specification SABS 1519-1990, "Road Signs", published by the South African Government Notice No. 1851 of 1 December 1995, and the words "coefficient of retro-reflection, colour, luminance factor, specular glass and weathering", must bear the same meaning as assigned thereto by such specification;
 - (b) For yellow, white, black and red road marking material and golden yellow paint, Standard Specification SABS 1 091:1975, "National colour standards for paint" published in the South African Government Notice No. 1549 of 21 July 1989;
 - (c) For red, yellow, clear and green road studs, Standard Specification SABS 1442-1987, "Road studs" published in the South African Government Notice No. R.1851 of 1 December 1995; and
 - (d) For red, yellow and green illuminated traffic signals, Standard Specification: SABS 1459-1988 "Traffic Lights" published in the South African Government Notice No. R.1851 of 1 December 1995.
- (3) If a road traffic sign is displayed with a colour that differs in shade from the colour specified in subregulation (2), the validity of such sign is, in the absence of proof of prejudice, not be affected thereby.
- [The word "be" in the phrase "not be affected thereby" is superfluous.]**
- (4) The reverse side of a road sign, other than a road sign with an aluminium background, must be grey, except that, irrespective of the material of manufacture, the reverse side of a stop sign must be white semi-matt.
- (5) (a) Subject to this Chapter, the colour of the standard or post specifically erected for the display of a road sign must, where the standard or post is -
- (i) of steel, be grey, but if the steel has been treated this requirement does not apply;
 - (ii) of wood, be the colour of the wood as treated;

REGULATIONS
Road Traffic and Transport Act 22 of 1999
Road Traffic and Transport Regulations, 2001

- (iii) of concrete, be the natural colour of the concrete.
- (b) In the case of a traffic signal the standard or post must be golden yellow, but this paragraph does not apply to an overhead traffic signal mounted on a gantry or a cable.
- (6) Light reflecting variable message road signs must conform to the dimensional and colour requirements in this regulation.
- (7) (a) Light emitting variable message road signs may be used to display a regulatory, warning, guidance or information message.
- (b) Any light emitting variable message road sign, which conveys a regulatory or warning message must display the message -
 - (i) in the same shape as the equivalent standard sign;
 - (ii) with an illuminated red or white border, as the case may be: and
 - (iii) with an illuminated message in white letters, numbers or symbols on a semi-matt black background.
- (c) A combination of a standard road sign and variable message road sign may be used.
- (8) Retro-reflective material referred to in subregulation (2)(a) must bear a permanent mark to identify the class and the manufacturer of such material.

Manner of display of road signs and road signals

- 318.** (1) Subject to this Chapter, a road sign or a road signal must -
- (a) be displayed on a public road where its significance is applicable, to face oncoming traffic;
 - (b) be placed in a position and at a height which is the most advantageous with regard to the design, alignment and other features of the public road concerned;
 - (c) be displayed essentially in conformity with an approved road traffic signs manual.
- (2) A temporary road sign must only be used for a temporary condition.
- (3) Where an association or club is authorised to display a road traffic sign as referred to in section 74(5) of the Act, no badge or other token on any road sign so displayed may be outside the outline of that road sign, but in any case where this is not possible, it must be in the immediate proximity to the junction of the road sign with the standard or post and contained in an area not exceeding 10 percent of the area of the face of such sign. In all other cases the badge or token may be placed where space is available on the road sign, preferably in a corner but the nearest edge of the badge or token may not be more than 100 millimetres from the edge of the road sign.

REGULATIONS
Road Traffic and Transport Act 22 of 1999
Road Traffic and Transport Regulations, 2001

(4) If a road traffic sign or traffic signal is mounted over a portion of the roadway, the minimum clearance between the underside of the sign or traffic signal and the road surface must be five comma two metres, except for road traffic signs R204, W415 and W320.

- (5) In the case where two road traffic signs are in conflict with one another -
- (a) a temporary road traffic sign takes precedence over any other sign;
 - (b) subject to paragraph (a), a control regulatory sign takes precedence over any other sign;
 - (c) a bus, minibus or minibus reservation sign R301, R310 or R311 takes precedence over a parking or stopping sign including a no parking and no stopping sign.
- (6) (a) A road traffic sign may be used in combination with another road traffic sign on the same post to -
- (i) selectively restrict the application of the road traffic sign by displaying a two part message where the lower message modifies the significance of the upper message;
 - (ii) improve the comprehensibility of the sign by means of supplementary information;
 - (iii) improve the conspicuousness of the road traffic sign;
 - (iv) when used in combination with a guidance sign, indicate the sign's applicability.
- (b) The combinations referred to in paragraph (a) may not comprise of combinations of permanent and temporary signs.
- (7) (a) A regulatory sign, except a control regulatory sign, may be displayed as a selective restriction sign.
- (b) Examples of selective restriction signs are illustrated in Section H of the Regulatory Signs of Schedule 2.
- (8) (a) A road traffic sign may be supplemented in order to improve the comprehensibility of such sign by -
- (i) in the case of a regulatory sign or signal or warning sign, the addition below the sign of an information or supplementary plate;
 - (ii) the inclusion of a regulatory or warning sign in a guidance sign.
- (b) Examples of regulatory combination signs are illustrated in Section 1 of the Regulatory Signs of Schedule 2, and of warning combination signs in Section C of the Warning Signs of Schedule 2.
- (9) (a) The conspicuousness of a road sign may be improved by -
- (i) displaying the sign on a high visibility background;

REGULATIONS
Road Traffic and Transport Act 22 of 1999
Road Traffic and Transport Regulations, 2001

- (ii) displaying the sign in combination with one or more yellow flashing signals;
 - (iii) internal or external illumination.
- (b) The colours of a high visibility background sign must be -
- (i) for a permanent sign, white retro-reflective for the background and red retro-reflective for the border;
 - (ii) for a temporary sign yellow retro-reflective for the background and black semi-matt for the border.
- (c) Examples of high visibility regulatory signs are illustrated in Sections Hand I of the Regulatory Signs of Schedule 2, and of high visibility warning signs in Section C of the Warning Signs of that Schedule.
- (10) When a continuous longitudinal road marking is used in combination with road-studs, small breaks in the continuity of the road marking may occur to accommodate the road-studs.
- (11) An overhead lane direction control signal S 16 or S 17 must be used to control the direction of movement in a particular lane of a public road so that road users may use the lane in one direction during certain periods of the day and in the opposite direction during other periods.
- (12) (a) A traffic signal must -
- (i) comprise light signals arranged vertically so that the topmost signal is red, the central signal is yellow and the lower signal is green, but -
 - (aa) the topmost signal may include more than one red light signal arranged horizontally;
 - (bb) the central light may include more than one yellow light signal arranged horizontally;
 - (cc) the lower light signal may include more than one green light signal arranged vertically or horizontally;
 - (dd) a special supplementary traffic signal S10L and S10R may be used with only a yellow and a green arrow;
 - (ee) a pedestrian traffic signal S11 must comprise two light signals arranged vertically and the upper light signal must be red and the lower light signal must be green;
 - (ff) a special traffic signal S12 may comprise two light signals arranged vertically and the upper light signal must be red and the lower light signal green;

REGULATIONS
Road Traffic and Transport Act 22 of 1999
Road Traffic and Transport Regulations, 2001

- (gg) a pedal cyclist traffic signal S20 must comprise two light signals arranged vertically and the upper light signal must be red and the lower light signal must be green;
 - (ii) have a basic sequence which must be red, green, yellow and red and the cycle time must be such as may be required by the movement of traffic; and
 - (iii) be so designed that the traffic signal head prevents, as far as possible, any traffic signal from being seen from a direction to which its light signals do not apply.
- (b) (i) Subject to the provisions of subparagraphs (ii) to (iv), there must, at a signalised junction or signalised pedestrian or pedal cyclist crossing, be at least two traffic signal faces for the control of vehicular traffic for each direction from which vehicular traffic may approach the junction and these two traffic signals, must be arranged so that both are on the far side of the junction and so that there is one on either side of the roadway;
- (ii) When a light signal is provided for turning vehicular traffic, only one traffic signal may be required for the control of such traffic and such light signal may be located on the left side of the roadway provided it is sufficiently far away from the stop line RTM1 that drivers who stop behind the line can see the full traffic signal;
- (iii) When the roadway is divided, the right hand traffic signals must be situated on the median island;
- (iv) When the required traffic signals cannot be readily seen by a driver of an approaching vehicle an additional traffic signal may be provided -
- (aa) as an additional traffic signal on the far side of the junction;
 - (bb) as an additional traffic signal on the near side of the junction; or
 - (cc) as an elevated traffic signal situated above the roadway;
- (c) When it is necessary to increase the conspicuousness of a traffic signal in relation to its background, a background screen, be provided and such a screen must comply with Standard Specification SABS 1459-1988: Traffic Lights;
- (d) The traffic signals at a junction must be -
- (i) not less than three metres apart; and
 - (ii) not more than 20 metres apart, but in the case where it is unavoidable that the traffic signals are more than 20 metres apart, an additional traffic signal facing in the same direction as the other traffic signals must be installed in such a manner that no adjacent traffic signals are more than 16 metres apart.
- (e) When a separate right hand turn light signal is required at least two traffic signals that incorporate a green arrow light signal must be provided on two separate supports subject to the requirement of subparagraphs (d)(i) and (d)(ii) and at least one of such traffic signals must be a S8 traffic signal.

REGULATIONS
Road Traffic and Transport Act 22 of 1999
Road Traffic and Transport Regulations, 2001

(13) The traffic control at a junction or pedestrian or pedal cycle crossing may include the use of road signs, road markings and road signals. The traffic control precedence is as follows:

- (a) A road sign which prohibits or prescribes directional movement of traffic at a junction or pedestrian or pedal cycle crossing which is controlled by a traffic signal has precedence over any light signal which permits right-of-way; and
- (b) a light signal which has the significance that traffic must stop has precedence over any other road traffic sign.

(14) No road sign except -

- (a) a street name sign;
- (b) a direction route marker sign;
- (c) an information sign relating to the function of the traffic signal;
- (d) a one-way roadway sign;
- (e) a no entry sign;
- (f) a left turn prohibited, right turn prohibited or u-turn prohibited sign; or
- (g) a proceed straight only, proceed left only, or proceed right only sign;

may be used in conjunction with a traffic signal, and such signs may be mounted on the same post.

(15) When no light signal is illuminated on an approach to a junction the driver of a motor vehicle must act as for a 3-way stop R 1.3 or a 4-way stop sign R1.4.

(16) If a traffic signal is out of order, either all the signals must not be illuminated or all red light signals must be flashing.

(17) A flashing red arrow light signal may not be used in conjunction with a green man light signal at a junction.

(18) Every flashing light signal must operate at a cycle frequency of between one and two flashes per second.

- (19) (a) A flashing red signal must comprise a red disc light signal.
- (b) When red flashing signals are used at a railway crossing a two light signal must -
 - (i) be mounted below stop sign R1 and an above railway line hazard marker W403 or W404, as applicable;
 - (ii) be illuminated in alternating flashing mode only when a train is approaching; and

REGULATIONS
Road Traffic and Transport Act 22 of 1999
Road Traffic and Transport Regulations, 2001

- (iii) be situated on the near side of the railway crossing, on the left side of each approach roadway.
- (20) Overhead Lane direction control signals must -
- (a) comprise light signals, S16, S17, S18 and S19 mounted side by side with S16 on the right of S17 and S18 or S19 in advance of S16 and S17 as viewed by a driver, above each lane subjected to reversed flow traffic movement and for both directions of movement, but if the light signal is a matrix of light sources, signals 16 and 17 may comprise one unit for each lane and for both directions of movement in that lane.
 - (b) conform to the requirements of Standard Specifications: SABS 1459-1988 "Traffic Lights";
 - (c) be so mounted that the centre of the light signals is not more than six comma two metres above the roadway and lower edge not less than five comma two metres above the roadway; and
 - (d) not be displayed over a lane to indicate the permitted direction of traffic movement except when such lane is subject to reversed flow in the direction of traffic movement.
- (21) A flag must be 600 millimetres by 600 millimetres and must be red or orange.

Signs regulating parking, stopping and hawkers prohibited

319. (1) A regulatory sign relating to the parking of a vehicle and the prohibition of hawkers must be displayed at each end and on that side of a portion of a public road where the significance of that sign is to be applicable, but -

- (a) a junction may not be included in any such section of a public road;
- (b) any other regulatory road traffic sign may be displayed within any such junction in which event that regulatory road traffic sign prevails over any sign relating to the parking of a vehicle;
- (c) in respect of any section of a public road which lies between the nearest intersecting public roads and which does not exceed 75 metres in length, parking or hawking may be prohibited or restricted in such section by displaying only one appropriate sign; and
- (d) where the significance of a sign is to apply to any portion of a public road other than the side of that public road, that sign may be displayed -
 - (i) on that portion of the public road to which its significance is to apply;
 - (ii) in the case of a no parking sign on any traffic island; or
 - (iii) other raised area surrounded by the roadway of the public road adjacent to that portion,

REGULATIONS
Road Traffic and Transport Act 22 of 1999
Road Traffic and Transport Regulations, 2001

and in the case of a parking prohibited sign, its significance applies to any parking bay demarcated within a distance of 500 millimetres from that sign and if that bay is one of several demarcated parking bays adjoining one another, to all the adjoining parking bays within a distance of 75 metres from that sign and, for the purposes of this paragraph, parking bays demarcated within two and a half metres of each other are deemed to be adjoining parking bays.

(2) A regulatory sign prohibiting or restricting the stopping of a vehicle must be displayed at each end and on that side of the section of a public road where the significance thereof is applicable, but -

- (a) a junction may not be included in any such section of public road; or
- (b) in respect of any section of a public road which lies between the nearest intersecting public roads and which does not exceed 75 metres in length, stopping may be prohibited or restricted in that section by displaying only one appropriate sign.
- (3) A regulatory sign relating to the parking or stopping of a vehicle may, unless it is displayed with the face parallel to the lateral line of the public road, display a similar sign on the reverse side.

Authority to enter premises contrary to regulatory sign

320. Where a regulatory sign applies which reserves a public road or portion of a public road for a specific category of vehicle, the driver of a vehicle, other than a driver of a vehicle of the class referred to by that sign, may only cross that public road, or the portion of that public road, if -

- (a) he or she cannot otherwise enter or leave any premises adjacent to that road or portion of road; and
- (b) it is safe to do so.

Prohibition on advertising material on or attached to road traffic sign or used in advertisement

321. (1) A person may not display or allow to display any advertising material on or attached to a road traffic sign except -

[The phrase “allow to display” should be “allow to be displayed”.]

- (a) that a single advertisement may be displayed on each side of a street name sign GL1 or a suburb name sign GL2 in combination with such signs;
- (b) that the manufacturer of such sign may display his or her name at the back of that sign; or
- (c) in the circumstances referred to in section 74(7) of the Act, but it must be displayed substantially in conformity with an approved road traffic signs manual.

(2) A person may not use a road traffic sign in an advertisement where that advertisement is visible for a road user while travelling on a public road.

REGULATIONS
Road Traffic and Transport Act 22 of 1999
Road Traffic and Transport Regulations, 2001

Transitional provisions relating to colours of road traffic signs

322. (1) A road traffic sign which could, prior to the commencement of this Chapter, validly be displayed in terms of the repealed Ordinance, may, despite the provisions of this Chapter, be displayed on a public road until 31 December 2003.

(2) A road traffic sign contemplated in subregulation (1) has the same meaning assigned to a corresponding road traffic sign in Schedule 2, but a stop sign R1 which could have been displayed prior to the commencement of this Chapter has, when it is displayed as a 3-way or 4-way stop sign, the same significance as stop signs R1.3 and R1.4, respectively, as indicated in Schedule 2.

PART 2 **SPEED LIMITS**

General speed limits

323. (1) Unless an appropriate road traffic sign is displayed indicating a lower speed limit, every public road or section thereof -

- (a) within an urban area, is subject to a general speed limit of 60 kilometres per hour;
- (b) outside an urban area, is subject to a general speed limit of -
 - (i) 100 kilometres per hour if it is not a tarred road; and
 - (ii) 120 kilometres per hour if it is a tarred road.

(2) A general speed limit of 120 kilometres applies in respect of every freeway unless an appropriate road traffic sign is displayed indicating a lower speed limit.

(3) A person may not drive in excess of the general speed limit referred to in subregulations (1) and (2) or the speed limit indicated by an appropriate road traffic sign.

(4) The driver of a security service vehicle as defined in section 1 of the Act may drive in excess of the general speed limit referred to in subregulations (1) and (2) if -

- (a) the Minister is satisfied that the security enterprise, which is the owner of the security service vehicle, complies with the provisions of the Security Enterprises and Security Officers Act, 1998 (Act No. 19 of 1998) and is ensured for public liability to the amount determined by the Minister;
- (b) the security service vehicle is the emergency response vehicle of the security enterprise being used while responding to an emergency.

Prohibition on speed detectors, jammers and similar devices

323A.(1) A person may not operate on a public road a motor vehicle in which is fitted or affixed to such motor vehicle any device that interferes or detect the use of a speed monitoring or measuring device.

REGULATIONS
Road Traffic and Transport Act 22 of 1999
Road Traffic and Transport Regulations, 2001

[The word “interferes” should be the phrase “interferes with”.
 The verb “detect” should be “detects” to accord with the subject “device”.]

(2) A person may not have in his or her possession whilst travelling in a motor vehicle a device that interferes or detects the use of a speed monitoring or measuring device.

[The word “interferes” should be the phrase “interferes with”.]

[regulation 323A inserted by GN 81/2010]

Speed limit for particular class of vehicle

324. (1) In terms of section 76(3) of the Act, a speed limit of -

- (a) 80 kilometres per hour, subject to the proviso to that section, applies in respect of -
 - (i) a goods vehicle, with a gross vehicle mass exceeding 9 000 kilograms;
 - (ii) a combination of motor vehicles consisting of a goods vehicle, being the drawing vehicle, and one or two trailers of which the sum of the gross vehicle mass of the goods vehicle and of the trailer or trailers exceeds 9 000 kilograms; or
 - (iii) an articulated motor vehicle, of which the gross combination mass of the truck-tractor exceeds 9 000 kilograms;
- (b) 100 kilometers per hour, subject to the proviso of that section, applies to a motor vehicle contemplated in regulation 284(1)(c) and (d).

[paragraph (b) substituted by GN 205/2004]

(2) A person may not operate on a public road -

- (a) a goods vehicle referred to in subregulation (1)(a), unless a sign is displayed on the rear of the goods vehicle, denoting that the goods vehicle is subject to a speed limit of 80 kilometres per hour;
- (b) a bus referred to in subregulation (1)(b), unless a sign is displayed on the rear of the bus, denoting that the bus is subject to a speed limit of 100 kilometres per hour.

(3) A sign referred to in subregulation (2) must comply with the requirements of the Standard Specification SABS 1329 “Retro-reflective and Fluorescent Warning Signs for Road Vehicles”, Part 3: 1987 “Signs other than triangles, chevron signs and abnormal load vehicle signs”, published by the South African Government Notice No. 2227 of 9 October 1987, with respect to the colours displayed on that sign.

Speed limit in relation to tyres

325. Despite regulations 323 and 324, a person may not operate on a public road a minibus, bus or goods vehicle, which according to its registration certificate -

- (a) was registered for the first time prior to 1 January 1989 and with a gross vehicle mass exceeding 3 500 kilograms; or

REGULATIONS
Road Traffic and Transport Act 22 of 1999
Road Traffic and Transport Regulations, 2001

- (b) was registered for the first time on or after 1 January 1989, and which is fitted with pneumatic tyres, at a speed in excess of the speed referred to in the Standard Specification SABS 1550:1992 “Motor Vehicle Tyres and Rims: Dimensions and Loads”, Part I - 1992, “General” Part 2 “Passenger Car Tyres”, Part 3 “Commercial Vehicle Tyres”, published by the South African Government Notice No. 2006 of 17 July 1992, or as approved by the manufacturer of the tyre concerned.

Speed limit in relation to braking capability

326. (1) A person may not operate on a public road a tractor or trailer referred to in regulation 170(2) at a speed in excess of 35 kilometres per hour.

(2) A motor vehicle referred to in subregulation (1) may be fitted with a sign denoting that the motor vehicle is subject to a speed restriction of 35 kilometres per hour, and that sign must comply with the requirements of the Standard Specification SABS 1329, “Retro-reflective and fluorescent warning signs for road vehicles”, Part 3: 1987 “Signs other than triangles, chevron signs and abnormal load vehicle signs” published by the South African Government Notice N. 2227 of 9 October 1987.

(3) The sign referred to in subregulation (1) is required to be displayed from 1 January 2002.

Speed measuring instrument

326A. When ascertaining the speed at which a motor vehicle was travelling, a traffic officer shall ascertain such speed by using an instrument that complies with the Namibian set Standard (NAMS/SANS 1795): Road Traffic Enforcement Systems: (Part 0, 1, 3, 4, & 5) which Standard in terms of section 94 of the Act, is available for free inspection during office hours at the Deputy Permanent Secretary of Transport, 6719 Bell Street, Snyman Circle. 7th Floor, Room 706 or 728 or at the Namibian Standards Institution, Channel Life Tower, M2, Post Street Mall, Windhoek.

[regulation 326A inserted by GN 156/2015 and substituted by GN 130/2018]

CHAPTER 8

MATTERS RELATING TO THE RULES OF THE ROAD

PART 1

RULES OF THE ROAD

Vehicle to be driven on left side of roadway

327. (1) Any person driving a vehicle on a public road must do so by driving on the left side of the roadway and, where the roadway is of sufficient width, in such a manner as not to encroach on that half of the roadway to his or her right, but such encroachment is permissible -

- (a) where it can be done without obstructing or endangering other traffic or property which is or may be on that half and for a period and distance not longer than is necessary and prudent and provided that it is not prohibited by a road traffic sign; or
- (b) in compliance with a direction of a traffic officer or a road traffic sign.

REGULATIONS
Road Traffic and Transport Act 22 of 1999
Road Traffic and Transport Regulations, 2001

(2) Subregulation (1) does not apply in the case of a public road that is restricted to traffic moving thereon in one direction only.

Driving on divided public road

328. (1) Whenever any public road is divided into two or more roadways by means of an intervening space or by a physical barrier or dividing section so constructed as to impede vehicular traffic, no person may drive a vehicle on that public road except on the left-hand roadway, unless directed or permitted by an appropriate road traffic sign or a traffic officer to use another roadway.

(2) A person may not drive a vehicle on, over, across or within any intervening space, barrier or section referred to in subregulation (1), except through an opening in such space, barrier or section or at a cross-over or intersection, but no person may so drive through any such opening or at any such cross-over or intersection where it is prohibited by an appropriate road traffic sign or by a traffic officer.

(3) Subregulation (2) does not apply to a traffic officer in the performance of his or her duties.

Passing of vehicle

329. (1) Subject to subregulations (2) and (4) and regulation 327, the driver of a vehicle intending to pass any other vehicle travelling in the same direction on a public road must pass to the right thereof at a safe distance and may not again drive on the left side of the roadway until safely clear of the vehicle so passed, but in the circumstances as aforesaid, passing on the left of the other vehicle is permissible if the person driving the passing vehicle can do so with safety to himself or herself and other traffic or property which is or may be on the road, and -

- (a) the vehicle being passed is turning to its right or the driver thereof has signalled his or her intention of turning to his or her right;
- (b) the road is a public road in an urban area and -
 - (i) is restricted to vehicles moving in one direction; and
 - (ii) the roadway is of sufficient width for two or more lines of moving vehicles;
- (c) the road is a public road in an urban area and the roadway is of sufficient width for two or more lines of moving vehicles moving in each direction;
- (d) the roadway of the road is restricted to vehicles moving in one direction and is divided into traffic lanes by appropriate road traffic signs; or
- (e) he or she is driving in compliance with the directions of a traffic officer or is driving in traffic which is under the general direction of a traffic officer, and in accordance with such direction,

but in no event may any passing referred to in paragraph (a), (b), (c) or (d) be done by driving on the shoulders of the roadway or on the verge of the public road.

REGULATIONS
Road Traffic and Transport Act 22 of 1999
Road Traffic and Transport Regulations, 2001

(2) The driver of a vehicle may not pass other traffic travelling in the same direction on a public road when approaching -

- (a) the summit of a rise;
- (b) a curve; or
- (c) any other place,

where his or her view is so restricted that any such passing could create a hazard in relation to other traffic which might approach from the opposite direction, unless -

- (i) he or she can do so without encroaching on the right-hand side of the roadway; or
- (ii) the roadway of the road is restricted to vehicles moving in one direction.

(3) The driver of a vehicle on a public road must, except in the circumstances where passing on the left of a vehicle is allowed under subregulation (1), upon becoming aware of other traffic travelling in the same direction and wishing to pass his or her vehicle, drive his or her vehicle as near to the left edge of the roadway as is possible, without endangering himself or herself or other traffic or property on the roadway, and may not accelerate the speed of his or her vehicle until the other vehicle has passed.

(4) When about to pass oncoming traffic, the driver of a vehicle on a public road must ensure that the vehicle driven by him or her does not encroach on the roadway to his or her right in such a manner as may obstruct or endanger oncoming traffic.

(5) The driver of a vehicle intending to pass a stationary bus on a public road must do so with due care for the safety of persons who are approaching or leaving or may approach or leave the bus.

Prohibition on driving on shoulder of public road

330. A person may not drive a motor vehicle on the shoulder of a public road.

Crossing or entering public road or traffic lane

331. (1) The driver of a vehicle may not cross a public road unless the road is clear of moving traffic for a sufficient distance to allow him or her to cross the road without obstructing or endangering any such traffic.

(2) The driver of a vehicle may not enter a public road unless he or she can do so without endangering himself, herself or other traffic.

(3) The driver of a vehicle on a public road divided into traffic lanes by appropriate road traffic signs may not turn from one lane into or across another lane unless he or she can do so without obstructing or endangering other traffic.

Driving signals

332. The driver of a vehicle on a public road who intends to stop the vehicle or suddenly reduce the speed thereof, or to turn the vehicle to the left or to the right, or to move the vehicle

REGULATIONS
Road Traffic and Transport Act 22 of 1999
Road Traffic and Transport Regulations, 2001

to the left or right on the roadway, must give a conspicuous signal, in the manner prescribed in this Chapter, of his or her intention, visible to any person approaching the vehicle from the front, rear or side, and of a duration sufficient to warn that person of his or her intention.

Right of way at certain road junctions

333. The driver of a vehicle on a public road must, when he or she intends entering any portion of a public road which constitutes a junction of two or more public roads where vehicular traffic is required to move around a traffic island within the junction, yield the right of way to all vehicular traffic approaching from his or her right within that junction, unless his or her entry into that junction is controlled by an instruction given by a traffic officer or a direction conveyed by a road traffic sign requiring him or her to act differently.

Right of way for funeral vehicular procession

333A. (1) For the purposes of this regulation “vehicular funeral procession” means two or more vehicles accompanying a hearse which contains the body of a deceased person or cremated human remains, and which is led by -

- (a) a traffic escort vehicle followed by the hearse and other vehicles of the attendees of the funeral; or
- (b) in a local authority area, where there are no traffic escort vehicles to lead a funeral procession, a hearse or another designated vehicle followed by a hearse and other vehicles of the attendees of the funeral.

(2) Despite an instruction of a road traffic sign, a right of way provision contained in the Regulations or a regulation made under section 92 of the Act, but subject to regulation 337, a pedestrian and a driver of a motor vehicle, must yield right of way to a motor vehicle that is part a vehicular funeral procession.

(3) When a vehicular funeral procession enters an intersection, by reason of a road traffic sign or at the direction of a traffic officer, the other motor vehicles in the funeral procession may, subject to subregulation (4), continue to follow the funeral lead vehicle through the intersection despite an instruction of road traffic sign, a right of way provision contained in the Regulations, or a regulation made under section 92 of the Act.

- (4) The driver of a motor vehicle which is part of a vehicular funeral procession must -
 - (a) yield right of way to an approaching emergency service vehicle, by giving an audible and visible signal;
 - (b) yield right of way when directed to do so by a traffic officer;
 - (c) yield right of way to a State motorcade contemplated in regulation 337;
 - (d) follow the preceding motor vehicle in the vehicular funeral procession as closely as is practical and safe, and the provisions of regulation 341(1)(b) does not apply;

[The verb “does” should be “do” to accord with the subject “provisions”.]

- (e) have the headlamps of the vehicle concerned on, emitting a dipped beam;

REGULATIONS
Road Traffic and Transport Act 22 of 1999
Road Traffic and Transport Regulations, 2001

- (f) have the hazard lights of the vehicle on; and
- (g) exercise due care when participating in a vehicular funeral procession.

[regulation 333A inserted by GN 188/2006]

Procedure when turning

334. (1) The driver or a vehicle on a public road who desires to turn to the left must, having due regard to regulation 333, before reaching the point at which he or she intends to turn, indicate, in the manner prescribed in these regulations, his or her intention to turn and must steer his or her vehicle as near to the left side of the roadway on which he or she is travelling as circumstances may permit and must turn with due care and merge into such traffic stream as may at the time be travelling along, towards or into the public road into which he or she desires to turn.

(2) The driver or a vehicle on a public road who desires to turn to the right must, having due regard to regulation 333, before reaching the point at which he or she intends to turn, indicate in the manner prescribed in these regulations, his or her intention to turn and may not effect the turn unless he or she can do so without obstructing or endangering other traffic and -

- (a) if he or she is driving a vehicle on the roadway of a public road where the roadway is intended for traffic in both directions -
 - (i) he or she must steer the vehicle as near as circumstances may permit to the immediate left of the middle of the roadway on which he or she is travelling; and
 - (ii) where the turn is at an intersection, he or she may not encroach on the right half of the roadway into or out of which he or she intends to turn, except in the intersection itself, but must in any event pass to the left of any traffic island in that intersection or comply with the direction conveyed by any appropriate road traffic sign; or
- (b) if he or she is driving a vehicle on a roadway of a public road where the roadway is intended for traffic in only one direction -
 - (i) he or she must steer the vehicle as near as circumstances permit to the right side of the roadway; and
 - (ii) where the turn is at an intersection he or she may not encroach on the right half of the roadway into which he or she intends to turn, except in the intersection itself but must in any event pass to the left of any traffic island in the intersection or comply with the direction conveyed by an appropriate road traffic sign, but where the turn is to be made into a roadway intended for traffic in only one direction, he or she may encroach on the right half of that roadway.

Towing of vehicles

REGULATIONS
Road Traffic and Transport Act 22 of 1999
Road Traffic and Transport Regulations, 2001

335. A person may not operate any vehicle on a public road while towing or drawing another vehicle save in the manner prescribed in these regulations for the towing or drawing of any vehicle by another vehicle on a public road.

Stopping of vehicles

336. Except in order to avoid an accident, or in compliance with regulation 337, a road traffic sign or with a direction given by a traffic officer, or for any cause beyond the control of the driver, a person may not stop a vehicle on the roadway of a public road -

- (a) alongside or opposite an excavation or obstruction on the public road if other traffic would be obstructed or endangered by stopping;
- (b) within any tunnel or subway or on any bridge or within six metres of any tunnel, subway or bridge;
- (c) on, or within six metres from the beginning or end of, any part of the roadway where the normal width thereof has for any reason been constricted;
- (d) in contravention of any road traffic sign;
- (e) on the right-hand side of the roadway facing oncoming traffic;
- (f) alongside or opposite any other vehicle on the roadway where the roadway is less than nine metres wide;
- (g) within the railway reserve at a level crossing;
- (h) within nine metres of his or her approaching side of a pedestrian crossing demarcated by appropriate road traffic signs; or
- (i) in any other place where the stopping of a vehicle would or would be likely to constitute a danger or an obstruction to other traffic.

Stopping of vehicle for State motorcade

337. (1) The driver of a vehicle on a public road must, when being approached or passed by a State motorcade -

- (a) where the road is demarcated into one traffic-lane for his or her direction of travel, stop the vehicle at the extreme left of the road;
- (b) where the road is demarcated into two traffic-lanes for his or her direction of travel, stop the vehicle in a safe position at the extreme left of the road if he or she is in the left lane, or adjacent to any vehicle which may be to his or her left if he or she is in the right lane;

[paragraph (b) amended by GN 205/2004]

- (c) where the road is demarcated into more than two lanes for his or her direction of travel, stop the vehicle in a safe position;

REGULATIONS
Road Traffic and Transport Act 22 of 1999
Road Traffic and Transport Regulations, 2001

- (d) where the vehicle is stopped in any lane at a controlled intersection, remain stationary and only proceed when instructed to do so by means of the hand signals of a traffic officer; or
- (e) where the road is not demarcated in two traffic-lanes for his or her direction of travel, stop the vehicle at the extreme left of the road.

(2) A person driving a vehicle may not overtake or attempt to overtake any vehicle in a State motorcade.

(3) For the purposes of this regulation, “controlled intersection” means an intersection where the traffic is controlled by an automatic traffic signal, hand signals of a traffic officer or a stop sign or give way sign.

Parking of vehicles

338. (1) A person may not park a vehicle on a public road -

- (a) in contravention of any road traffic sign;
- (b) in any place referred to in regulation 336;
- (c) on the same side as a fire hydrant within an area bounded by the centre-line of the roadway and lines at right angles to the centre-line one and a half metres on either side of the hydrant, if the hydrant is clearly visible to and recognizable as such by drivers of moving vehicles, or if it is indicated by an appropriate road traffic sign;
- (d) in any place where the vehicle would obscure any road traffic sign;
- (e) in such manner as to encroach upon the sidewalk, if any; or
- (f) in such manner as to obstruct any private or public vehicular entrance to the public road.

(2) Subregulation (1)(c) does not apply to any vehicle, other than a motor vehicle, while it is being used in carrying on the business of street vendor, pedlar or hawker, unless it exceeds such maximum weight, height, length or mass as may be prescribed in these regulations.

(3) A person may not park a vehicle on any portion of the roadway (excluding the shoulders) of a public road outside an urban area or with any part of the vehicle within one metre of the edge of the roadway except in a parking place demarcated by an appropriate road traffic sign.

(4) A person may not park a vehicle on the roadway of a public road within an urban area -

- (a) within nine metres of the side from which he or she approaches a pedestrian crossing demarcated by appropriate road traffic signs, unless such parking is permitted by appropriate road traffic signs;
- (b) within live metres of any intersection unless such parking is permitted by a road traffic sign;

REGULATIONS
Road Traffic and Transport Act 22 of 1999
Road Traffic and Transport Regulations, 2001

- (c) upon or over the actuating mechanism of a traffic signal;
- (d) (i) with the outside of any left-hand wheel thereof more than 450 millimetres within the roadway; or
 - (ii) where the public road is restricted to vehicles moving in one direction and the vehicle is parked on the side of the roadway, with the outside of any right hand wheel thereof more than 450 millimetres within the roadway, unless such parking is permitted by an appropriate road traffic sign; or
- (e) which is less than five and a half metres wide unless the public road is restricted to vehicles moving in one direction and such parking is permitted by appropriate road traffic signs.

(5) A person may not park a motor vehicle on a traffic island or in a pedestrian mall or pedestrian lane.

(6) Whenever a vehicle has been parked in contravention of the Act or any by-law made under the Act, or in contravention of or in disregard of the directions of any road traffic sign or notice board as prescribed in these regulations, that vehicle may be removed or caused to be removed and impounded by a traffic officer, and unless the vehicle has been so parked in the course of a theft thereof, the owner bears the costs of the removal and impoundment.

Certain vehicles may be stopped and parked at any place where necessary

339. (1) Despite the provisions of regulations 336 and 338, the driver of an emergency service vehicle or a person who drives a vehicle while it is used in connection with the construction or maintenance of a public road or the rendering of an essential public service, may stop or park the vehicle concerned at any place where it may be necessary to do so.

(2) A vehicle stopped or parked in terms of subregulation (1) must, while it is so stopped or parked, display the identification lamps prescribed in regulation 194.

Compulsory stops

340. The driver of a vehicle on a public road must stop the vehicle -

- (a) in compliance with any direction conveyed by a road traffic sign or given by a traffic officer in uniform; or
- (b) at the request or on the signal of a person leading or driving any bovine animal, horse, ass, mule, sheep, goat, pig or ostrich on the public road.

General duties of driver or passenger of vehicle on public road

341. (1) A person driving or having a vehicle on a public road may not -

- (a) cause the vehicle to travel backwards unless it can be done in safety, or cause it to run backwards for a distance or time longer than may be necessary for the safety or reasonable convenience of any occupant of that vehicle or of other traffic on the public road;

REGULATIONS
Road Traffic and Transport Act 22 of 1999
Road Traffic and Transport Regulations, 2001

- (b) follow another vehicle more closely than is reasonable and prudent having regard to the speed of the other vehicle and the traffic on and the condition of the roadway, or more closely than is prescribed in these regulations;
 - (c) permit any person, animal or object to occupy any position in or on the vehicle which may prevent the driver thereof from exercising complete control over the movements of the vehicle or signalling his or her intention of stopping, slowing down or changing direction;
 - (d) when driving the vehicle, permit any person to take hold of or interfere with the steering or operating mechanism of the vehicle;
 - (e) when driving the vehicle, occupy such position that he or she does not have complete control over the vehicle or does not have a full view of the roadway and the traffic ahead of the vehicle;
 - (f) allow the vehicle to remain unattended on the road without setting its brake or adopting such other method as will effectively prevent the vehicle from moving from the position in which it is left;
 - (g) if the vehicle is parked or is stationary at the side of the road, drive the vehicle from that position unless he or she is able to do so without interfering with moving traffic approaching from any direction and without endangering himself, herself or other traffic;
 - (h) fail to give an immediate and absolute right of way to a vehicle sounding a device provided for in section 75 or 77 of the Act;
 - (i) allow any portion of his or her body to protrude beyond the vehicle while it is in motion on the road except for the purpose of giving any hand signal which he or she is required or authorised to give in terms of these regulations or unless he or she is engaged in examining or testing or parking the vehicle;
 - (j) permit any person or animal to occupy the roof, any step or running board or any other place on top of the vehicle while it is in motion, but this paragraph does not apply to the driver of a refuse removal vehicle or a firefighting vehicle used in the execution of his or her duties;
- [paragraph (j) substituted by GN 205/2004]**
- (k) cause or allow the engine thereof to run in such manner that it emits smoke or fumes which would not be emitted if the engine were in good condition or ran in an efficient manner;
 - (l) cause or allow the engine thereof to run while the motor vehicle is stationary and unattended;
 - (m) negligently or wilfully deposit or cause or permit to be deposited any petrol or other liquid fuel or any oil or grease or other flammable or offensive matter, ashes or other refuse, of whatever nature, from the vehicle upon or alongside the road; or
 - (n) cause or allow the engine thereof to run while petrol or other flammable fuel is being delivered into the fuel tank of the vehicle, or cause or allow the engine to be

REGULATIONS
Road Traffic and Transport Act 22 of 1999
Road Traffic and Transport Regulations, 2001

started up before the delivery of the petrol or other flammable fuel into the fuel tank of the vehicle has been completed and the cover of the fuel tank has been replaced.

(2) No person, other than the driver, may take hold of or interfere with the steering or operating mechanism of a vehicle while it is in motion on a public road, unless it may reasonably be inferred that the driver is no longer capable of steering or controlling the vehicle.

(3) A passenger in a vehicle on a public road may not permit any part of his or her body to protrude beyond the vehicle.

(4) A person may not enter or alight from any vehicle on a public road unless the vehicle is stationary and unless he or she can do so without endangering himself, herself or other users of the road.

(5) A person may not drive, pull or push a vehicle upon a sidewalk, but this subregulation does not apply to a perambulator, invalid chair, baby cart or child's play vehicle.

Prohibition on use of communication device while driving

342. (1) A person may not drive a vehicle on a public road -

- (a) while holding a cellular or mobile telephone or any other communication device in one or both hands or with any other part of the body;
- (b) while using or operating a cellular or mobile telephone or other communication device unless it is affixed to the vehicle or is part of the fixture in the vehicle and remains so affixed while being used or operated, or is specially adapted or designed to be affixed to the person of the driver as headgear, and is so used, to enable the driver to use or operate that telephone or communication device without holding it in the manner contemplated in paragraph (a), and remains so affixed while being used or operated.

(2) Subregulation (1) does not apply to the driver of an emergency service vehicle, a traffic officer or a member of the Namibian Defence Force, while driving a motor vehicle in execution of their duties, but he or she must drive the vehicle with due regard to the safety of other road users.

(3) For the purposes of this regulation, the word "headgear" includes a device which is specially designed or adapted to allow the driver to use a cellular or mobile telephone or other communication device in such a manner that he or she does not hold it in one or both hands or with any other part of the body, and which is connected to the cellular or mobile telephone or other communication device, directly or indirectly, while being fitted to or attached to one or both ears of the driver.

Duties relating to motorcycle

343. (1) A person may not drive a motorcycle on a public road unless his or her feet are resting on the front foot-rests suitable for the purpose and, where the design of the motorcycle makes it possible to do so, he or she is seated astride on the saddle of the motorcycle.

REGULATIONS
Road Traffic and Transport Act 22 of 1999
Road Traffic and Transport Regulations, 2001

(2) A person may not carry a passenger on a motorcycle on a public road unless it has an engine with a cylinder capacity exceeding 50 cubic centimetres and unless the passenger is seated in a side-car or astride on a pillion attached to the motorcycle and, in the latter event, the feet of the passenger are resting on foot-rests suitable for that purpose.

(3) Subject to subregulation (2), not more than two persons may ride on a motorcycle on a public road, excluding a person riding in a side-car attached to the motorcycle.

(4) Not more than two adult persons may be carried in a side-car attached to a motorcycle on a public road.

(5) No person, animal or object may be carried on a motorcycle on a public road in front of the driver thereof, but an object of a non-bulky nature may be so carried if securely attached to the motorcycle or placed in a suitable carrier fitted thereon for that purpose and carried in such a way as not to obstruct the driver's view or prevent him or her from exercising complete control over the motorcycle.

(6) Persons, other than traffic officers in the performance of their duties, driving motorcycles on a public road, must drive in single file except in the course of overtaking another motorcycle, and two or more persons driving motorcycles may not overtake another vehicle at the same time, and where a public road is divided into traffic lanes, each lane is, for the purposes of this paragraph, regarded as a public road.

(7) A person driving a motorcycle on a public road or seated on a motorcycle may not take hold of any other vehicle in motion.

(8) Any person driving a motorcycle on a public road must do so with at least one hand on the handlebars of the motorcycle.

(9) Any person driving a motorcycle on a public road must do so in such manner that all the wheels of the motorcycle are in contact with the surface of the road at all times.

(10)

[subregulation (10) deleted by GN 205/2004]

Loud sound amplification system in motor vehicle and motor vehicles causing excessive noise

344. (1) For the purposes of this regulation "a sound amplification system" means a radio, television, tape player, compact disc player, loud speaker or other electronic device used for the amplification of sound.

(2) A person may not operate a motor vehicle or cause it to be operated on a public road while using a sound amplification system emitting sound from the vehicle that is audible under normal conditions from a distance of at least 33 metres from the vehicle.

(3) A person may not operate a motor vehicle or cause it to be operated on a public road, so as to cause excessive noise.

(4) This regulation does not apply to -

REGULATIONS
Road Traffic and Transport Act 22 of 1999
Road Traffic and Transport Regulations, 2001

- (a) an emergency service vehicle equipped with a siren in accordance with regulation 220 or a communication device which is used in the performance of the duties of an authorised officer or driver;
- (b) a motor vehicle equipped with a sounding device referred to in regulation 220(1)(a);
- (c) a motor vehicle or a sound amplification system used for an activity for which approval has been obtained from the local authority concerned in terms of the law relating to local authorities; or
- (d) a motor vehicle fitted with an anti-theft device which incorporates a siren.

[regulation 344 substituted by GN 188/2006]

Use of hooter

345. A person may not use the sounding device or hooter of a vehicle on a public road except when such use is necessary in order to comply with these regulations or on the grounds of safety.

Riding on pedal cycles

346. (1) A person may not ride a pedal cycle on a public road unless he or she is astride on the pedal cycle.

(2) Persons riding pedal cycles on a public road must ride in single file except in the course of overtaking another pedal cycle, and two or more persons riding pedal cycles may not overtake another vehicle at the same time.

(3) A person riding or seated on a pedal cycle on a public road may not take hold of any other vehicle in motion.

(4) A person riding a pedal cycle on a public road may not deliberately cause the pedal cycle to swerve from side to side.

(5) A person riding a pedal cycle on a public road may not carry thereon any person, animal or object which obstructs his or her view or which prevents him or her from exercising complete control over the movements of the pedal cycle.

(6) A person riding a pedal cycle on a public road must do so with at least one hand on the handle-bars of the pedal cycle.

(7) Whenever a portion of a public road has been set aside for use by persons riding pedal cycles, a person may not ride a pedal cycle on any other portion of that road.

(8) A person riding a pedal cycle on a public road or a portion of a public road set aside for use by persons riding pedal cycles, must do so in such manner that all the wheels of the pedal cycle are in contact with the surface of the road at all times.

Device running on rails

REGULATIONS
Road Traffic and Transport Act 22 of 1999
Road Traffic and Transport Regulations, 2001

347. (1) Whenever rails laid across any public road are used for the purposes of any locomotive or other device running on rails, whether such device is drawn or propelled, the person driving or in charge of the locomotive or device may not cause or allow the locomotive or device to cross the public road unless he or she has given sufficient warning to users of the roadway of the intention to drive, draw or propel the locomotive or device across the road.

(2) A person driving or in charge of any locomotive or device mentioned in subregulation (1), may not cause or allow it to be stopped on a public road in such a manner as to obstruct or hinder traffic on the road, but this subregulation does not apply to a locomotive or device mentioned in subregulation (1) which is temporarily stopped on a public road -

- (a) in compliance with an order or instruction, whether in writing or otherwise or a hand signal or any other signal in relation to the use of that locomotive or device;
- (b) for the purpose of loading or off-loading goods or allowing persons to board or alight at any place: or
- (c) for shunting purposes.

Animal on public road

348. (1) Subject to subregulation (2), a person may not leave or allow any bovine animal, horse, ass, mule, sheep, goat, pig or ostrich to be on any section of a public road where that section is fenced or in any other manner closed along both sides, and a person may not leave that animal in a place from where it may stray onto that section of a public road.

(2) Subregulation (1) does not apply -

- (a) to any animal which is being ridden or is being used to draw a vehicle along a public road; or
- (b) to any animal which is being driven from one place to another in such manner as not to constitute a source of danger or injury to any person or vehicle using the road.

(3) In any prosecution for a contravention of subregulation (1), it must, in the absence of evidence to the contrary, be presumed that any animal referred to in subregulation (1) was left or allowed to be on the section of the public road or place concerned by the owner of the animal, and a section of a public road is regarded as fenced or enclosed along both sides even though there is an opening in the fence or other enclosure providing access to the road.

(4) A person may not drive any animal referred to in subregulation (1) -

- (a) along a public road during the period from sunset to sunrise, unless a person carrying a red light visible in clear weather for a distance of at least 150 metres tends the animal or, in the case of a flock or herd of more than 10 animals, a person tending the animals and carrying a light as aforesaid precedes and another person carrying a light as aforesaid follows the animals; or
- (b) along a public road during any other period, unless a person displaying *in* a conspicuous manner a red cloth, of not less than 300 millimetres by 300 millimetres, tends the animal or, in the case of a flock or herd of more than 10

REGULATIONS
Road Traffic and Transport Act 22 of 1999
Road Traffic and Transport Regulations, 2001

animals, a person tending the animals and displaying a cloth as aforesaid precedes and another person displaying a cloth as aforesaid follows the animals.

(5) A person in charge of an animal on a public road must tend the animal in such a manner as not to constitute an obstruction or danger to other traffic.

(6) A traffic officer may take charge of any animal referred to in subregulation (1) on a public road or take such steps in respect of the animal as determined by the Minister.

Animal-drawn vehicles

349. (1) A person may not operate an animal-drawn vehicle on a public road unless the name and address of the owner thereof is affixed or painted in a conspicuous position on the left side of the vehicle in letters not less than 25 millimetres high, but nothing herein contained applies in respect of a vehicle used solely for the conveyance of persons otherwise than for hire or reward.

(2) A person may not operate an animal-drawn vehicle on a public road unless the vehicle, the harness and other equipment thereof are in an efficient and safe condition.

(3) The owner of an animal-drawn vehicle may not cause or permit the vehicle to be used on a public road by any person who is not competent whether by reason of his or her age or otherwise to drive and control the vehicle.

(4) The driver of an animal-drawn vehicle on a public road must at all times give his or her undivided attention to the driving of the vehicle under his or her control, and if the vehicle is standing on a public road, the driver may not cease to retain control over every animal which is still harnessed to the vehicle, unless some other person competent to do so takes charge of every such animal, or every such animal is so fastened that it cannot move from the place where it has been left.

(5) A person may not operate a vehicle drawn by a team of animals not controlled by reins on a public road, unless there is a person leading the team and exercising control over the team.

(6) The driver or other person in charge of a vehicle drawn by any animal may not, on a public road outside an urban area, permit the vehicle to follow any other vehicle similarly drawn at a distance of less than 150 metres calculated from the foremost animal of the first-mentioned vehicle, except for the purpose of overtaking a vehicle travelling at a slower speed or when a vehicle travelling at a greater speed, having overtaken that vehicle, is drawing away from it.

Pedestrian's right of way in pedestrian crossing

350. (1) Where a pedestrian crossing is situated in conjunction with a traffic signal, a pedestrian may not enter the crossing except in accordance with the indications of the robot as prescribed in these regulations.

(2) In circumstances not referred to in subregulation (1), the driver of a vehicle must yield the right of way, slowing down or stopping if need be to so yield to a pedestrian crossing the roadway within a pedestrian crossing when the pedestrian is upon that half of the roadway upon which the vehicle is travelling, or when the pedestrian is approaching so closely from the opposite half of the roadway as to be in danger.

REGULATIONS
Road Traffic and Transport Act 22 of 1999
Road Traffic and Transport Regulations, 2001

(3) A pedestrian may not suddenly enter a pedestrian crossing and walk or run into the path of a vehicle which is so close that it is impossible for the driver to yield as contemplated in subregulation (2).

(4) Whenever any vehicle is stopped at a pedestrian crossing to permit pedestrians to cross the roadway, the driver of any other vehicle approaching from the rear may not pass the stopped vehicle.

Duties of pedestrians

351. (1) Whenever a sidewalk or footpath abuts on the roadway of a public road, a pedestrian may not walk on the roadway except for the purpose of crossing from one side of the roadway to the other or for some other sufficient reason.

(2) A pedestrian on a public road which has no sidewalk or footpath abutting on the roadway, must walk as near as is practicable to the edge of the roadway on his or her right-hand side so as to face oncoming traffic on the roadway, except where the presence of pedestrians on the roadway is prohibited by a prescribed road traffic sign.

(3) A pedestrian may not cross a public road without satisfying himself or herself that the roadway is sufficiently free from oncoming traffic to permit him or her to cross the road in safety.

(4) A pedestrian, when crossing a public road by means of a pedestrian crossing or in any other manner, may not linger on the road but must proceed with due despatch.

(5) No pedestrian on a public road may conduct himself or herself in such a manner as to or as is likely to constitute a source of danger to himself or herself or to other traffic which is or may be on the road.

(6) A pedestrian may cross a public road only at a pedestrian crossing or an intersection or at a distance further than 50 metres from that pedestrian crossing or intersection.

Racing and sport on public roads

352. (1) For the purposes of this regulation the expression “race or sport” includes -

- (a) any race, speed trial, reliability trial, hill climbing competition or sports meeting;
- (b) any other activity whatsoever -
 - (i) which may constitute a source of danger to traffic; or
 - (ii) which may hamper, impede or disrupt the normal flow of traffic.

(2) A person may not organize or take part in any race or sport on a public road, unless the prior written consent of the Minister has been obtained or, where the race or sport will take place wholly within the area of jurisdiction of a local authority, the prior written consent of that local authority has been obtained.

(3) In granting consent in terms of subregulation (2), the Minister or the local authority concerned, as the case may be, may -

REGULATIONS
Road Traffic and Transport Act 22 of 1999
Road Traffic and Transport Regulations, 2001

- (a) in addition to any requirement prescribed in these regulations, impose such further conditions as he or she or it may consider necessary;
- (b) exempt any person concerned with the race or sport for the duration thereof -
 - (i) from any provision of these regulations regarding any speed limit or determine another speed limit for the road concerned;
 - (ii) from any other provision of these regulations or from any by-law;
- (c) levy fees for defraying the expenses incurred by the Ministry or local authority concerned in connection with the race or sport.
- (4) Any consent granted in terms of subregulation (2) may be withdrawn at any time.

Convoys on public road

353. A person may not, on a public road, operate a motor vehicle forming part of a convoy of motor vehicles which are being delivered to a motor dealer or other person -

- (a) between the hours of 18h00 on a Friday or, in the case where such Friday is a public holiday, the Thursday immediately preceding such Friday, and 06h00 on a Monday, or in the case where such Monday is a public holiday, the Tuesday immediately succeeding such Monday; or
- (b) between the hours of 18h00 on the day immediately preceding Christmas Day and 06h00 on the day immediately succeeding the Day of Goodwill, to the extent to which such hours do not already fall within a period contemplated in paragraph (a).

Hindering or obstructing traffic on public road

354. (1) A person may not wilfully or unnecessarily prevent, hinder or interrupt the free and proper passage of traffic on a public road.

(2) Subject to the Act or any other law, a person may not place or abandon or cause to be placed or abandoned on a public road any object that may endanger or cause damage to traffic on the road.

Vehicle left or abandoned on public road

355. (1) Any vehicle standing on a public road in a position or in circumstances which in the opinion of a traffic officer, are likely to cause danger or an obstruction to other traffic on that road, may be removed forthwith to a safer place by that traffic officer or person or authority instructed by that traffic officer to remove the vehicle, but that traffic officer, person or authority must, in removing the vehicle, use such device or devices as may be necessary having regard to the public safety.

- (2) Any vehicle -
 - (a) parked in a place where -
 - (i) the stopping of a vehicle is prohibited in terms of regulation 336; or

REGULATIONS
Road Traffic and Transport Act 22 of 1999
Road Traffic and Transport Regulations, 2001

- (ii) a vehicle of a class to which such vehicle belongs may not be parked;
- (b) left for a continuous period of more than -
 - (i) 24 hours in the same place on a public road outside an urban area;
 - (ii) seven days in the same place on a public road within an urban area; or
 - (iii) seven days on the site of any vehicle testing station; or
- (c) found on a public road and to which -
 - (i) no licence number is affixed or, in the opinion of a traffic officer, a false licence number is affixed; or
 - (ii) no other number or anything else is affixed which may, in the opinion of a traffic officer, serve to identify the owner,

is deemed to have been abandoned by the owner and that vehicle may be removed by or on behalf of the authority having jurisdiction over the place or road concerned and that authority must take all reasonable steps to trace the owner, and the owner is, except in the case of a stolen vehicle, liable to that authority for the expenses incurred -

- (aa) in the removal of the vehicle;
- (bb) in keeping the vehicle in custody for a period not exceeding four months; and
- (cc) in connection with the endeavour to trace him or her,

and that authority may, subject to subregulation (3), retain possession of the vehicle until such expenses have been paid.

- (3) If -
 - (a) the owner is traced by the authority referred to in subregulation (2) and the owner fails to recover the vehicle and pay the expenses referred to in that subregulation within 14 days after being requested to do so; or
 - (b) after a lapse of one month from the date of removal contemplated in subregulation (2), the owner cannot be traced,

the vehicle or anything contained therein may be sold in the manner prescribed by any law governing the sale of movable property by that authority and, whenever possible, the authority which registered the vehicle must be advised of such sale.

(4) The proceeds of any sale referred to in subregulation (3) must be applied firstly to the costs of the removal, custody and sale of the vehicle concerned and all the endeavours made to trace the owner of the vehicle, and any balance must be paid to the owner thereof upon his or her establishing his or her claim thereto, but if no claim can be established within one year from the date of the sale, the balance is forfeited to the authority concerned.

REGULATIONS
Road Traffic and Transport Act 22 of 1999
Road Traffic and Transport Regulations, 2001

(5) If an authority referred to in subregulation (2) is unable to sell any vehicle as contemplated in subregulation (3), it may dispose of that vehicle in any manner it deems fit, and any moneys received as a result of such disposal is forfeited to that authority.

(6) An authority referred to in subregulation (2) may delegate, either generally or specifically, any power conferred upon it in terms of that subregulation to any person in its employment.

(7) The reasonable exercise by any person or authority of the powers conferred by this regulation does not render that person or authority subject to any liability in respect of the loss or theft of or damage to any vehicle or part thereof or of anything therein or thereon.

(8) Subject to any other law, a person may not leave a vehicle in the same place on a public road for a continuous period of more than seven days.

Damage to public roads

356. A person may not on a public road -

- (a) cause any wheel of any vehicle to drag or spin upon the surface of the roadway, except in the case of an emergency;
- (b) make use of chocks or shoes between any wheel of any vehicle moving along the roadway and the surface of the roadway; or
- (c) use any vehicle or thing or move any vehicle or thing on the roadway in a manner causing or likely to cause damage thereto.

Trading on public roads

357. Except -

- (a) on or in premises zoned or demarcated for that purpose by a competent authority in terms of any law; or
- (b) in such circumstances and in accordance with such requirements as may be prescribed or determined by a local authority regulation,

a person may not sell, display, offer for sale or deliver pursuant to a sale, any goods -

- (i) on or alongside a public road inside an urban area, within 180 metres of a railway level crossing or any road traffic sign denoting a blind corner or rise thereon or within five metres from any intersection thereon; or
- (ii) on or alongside any public road outside an urban area,

but where the Ministry is responsible for the maintenance of a public road inside an urban area, the competent authority of that urban area may not so zone or demarcate premises in that urban area situated alongside that road, without the prior approval of the Minister.

Special provisions relating to freeways

358. (1) A person may not operate on a freeway -

REGULATIONS
Road Traffic and Transport Act 22 of 1999
Road Traffic and Transport Regulations, 2001

- (a) a vehicle drawn by an animal;
- (b) a pedal cycle;
- (c) a motorcycle, other than a motor tricycle or a motor quadrucycle, with an engine with a cylinder capacity not exceeding 50 cubic centimetres or which is propelled by electrical power or which is a vehicle as contemplated in paragraph (b) of the definition of motor vehicle in the Act;
- (d) a motor tricycle or motor quadrucycle;
- (e) a vehicle with a mass not exceeding 210 kilograms and specially designed, constructed or adapted for the use of a person suffering from a physical defect or disability; or
- (f) a tractor.

(2) A person may not -

- (a) be on a freeway on foot except -
 - (i) within an area reserved for the stopping or parking of vehicles by an appropriate road traffic sign; or
 - (ii) for a cause beyond his or her control;
- (b) leave or allow an animal to be on a freeway except in or on a motor vehicle or within an area reserved for the stopping or parking of vehicles by an appropriate road traffic sign, or leave an animal in a place from where it may stray onto a freeway;
- (c) stop a vehicle on a freeway except -
 - (i) in compliance with a road traffic sign or a direction given by a traffic officer;
 - (ii) within an area reserved for the stopping or parking of vehicles by an appropriate road traffic sign; or
 - (iii) for any cause beyond his or her control;
- (d) give a hand signal when driving a motor vehicle on a freeway except for a cause beyond his or her control.

(3) In a prosecution for a contravention of subregulation (2)(b), it is, in the absence of evidence to the contrary, presumed that an animal was left or allowed on the freeway or place concerned by the owner of that animal.

(4) The provisions of -

- (a) subregulation (1)(f) does not apply to a person who operates a tractor in connection with the construction or maintenance of a freeway;

REGULATIONS
Road Traffic and Transport Act 22 of 1999
Road Traffic and Transport Regulations, 2001

- (b) subregulation (2)(a) does not apply to -
- (i) a traffic officer while he or she is engaged in the performance of his or her duties;
 - (ii) a person while he or she is engaged in rescue or salvage work;
 - (iii) a person while he or she is engaged in the construction or maintenance of a freeway or the rendering of an essential public service; or
 - (iv) a person while he or she is engaged in civil protection as contemplated in the Civil Defence Ordinance, 1979 (Ordinance No. 3 of 1979); and

**[The Civil Defence Ordinance 3 of 1979 was repealed
 by the Disaster Risk Management Act 10 of 2012.]**

- (c) subregulation (2)(c) does not apply to -
- (i) the driver of -
 - (aa) an ambulance, fire-fighting vehicle or rescue vehicle; or
 - (bb) a breakdown vehicle while he or she is engaged in the salvaging of another motor vehicle;
 - (ii) a traffic officer who drives a vehicle in the performance of his or her duties;
 - (iii) a person who drives a vehicle while it is used in connection with the construction or maintenance of a freeway or the rendering of an essential public service; or
 - (iv) a person who drives a vehicle while he or she is engaged in civil protection as contemplated in the Civil Defence Ordinance, 1979.

(5) Where the driver of a motor vehicle which is being driven in the right-hand traffic lane or in the traffic lane furthest to the right on a freeway (hereinafter referred to as the first vehicle) becomes aware that the driver of another motor vehicle (hereinafter referred to as the second vehicle) intends to overtake the first vehicle, the driver of the first vehicle must steer that vehicle to a lane to the left of the one in which he or she is driving, without endangering himself, herself, other traffic or property on the freeway, and may not accelerate the speed of his or her vehicle until the second vehicle has passed.

(6) For the purposes of subregulation (5) the driver of the second vehicle may make the driver of the first vehicle aware that he or she intends to overtake the first vehicle by giving the driver thereof a visible signal by means of flashing the headlights of his or her vehicle.

PART 2
DRIVING SIGNALS AND SIGNALS FOR THE CONTROL OF TRAFFIC

Use of direction indicator

- 359.** (1) (a) The driver of a vehicle which is fitted with direction indicators in terms of regulations 212 to 218 must signal his or her intention to turn or move to

REGULATIONS
Road Traffic and Transport Act 22 of 1999
Road Traffic and Transport Regulations, 2001

the left or right by operating the direction indicator on the left or right side, as the case may be, of the vehicle.

- (b) The driver of a vehicle who has put a direction indicator into operation to signal his or her intention to turn or move to the left or right must, as soon as the need to signal has passed, cease to keep such indicator in operation.

(2) The driver of a tractor or of a combination of motor vehicles of which the drawing vehicle is a tractor, may in lieu of giving the appropriate hand signal, signal his or her intention to turn to the left or to the right or move to the left or the right by extending a portable direction indicator which complies with the following requirements:

- (a) When in use, the indicator must project at least 300 millimetres beyond the widest part of the vehicle or load thereon whichever is the wider;
- (b) the portable direction indicator must consist of a red fluorescent arrow of adequate rigidity, with dimensions as shown in Diagram A hereto, attached to a handle the length of which must comply with the requirements of paragraph (a); and
- (c) a yellow retro-reflector complying with the definition of a retro-reflector must be fitted to the front and back surfaces of the arrow as illustrated hereunder.

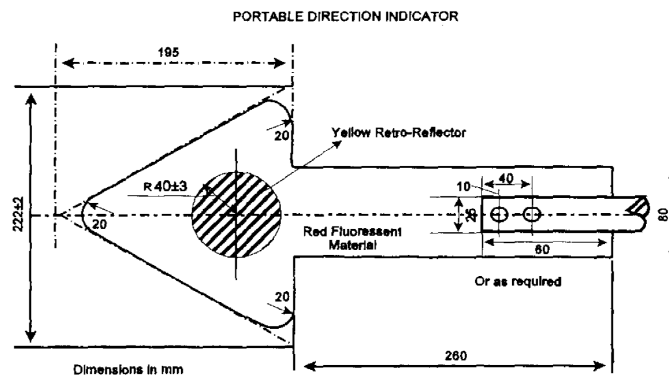

Left-turn hand signal

360. Subject to regulations 358(2)(d) and 362, the driver of a vehicle of which the direction indicator is temporarily out of order and who intends to turn to the left or move to the left on a public road must, before reaching the point at which he or she intends to turn or move to the left, extend his or her right arm sideward from the shoulder with the forearm in a vertical and downward position and move his or her forearm in a circular anti-clockwise motion, but in the case of a driver of a tractor, a two-wheel vehicle or an animal drawn vehicle, such driver may, in lieu of the hand signal aforesaid, extend his or her left arm and hand sideward from the shoulder and fully horizontal to the road with the palm of the hand turned to the front.

Right-turn hand signal

361. Subject to regulations 358(2)(d) and 362, the driver of a vehicle of which the direction indicator is temporarily out of order and who intends to turn to the right or move to the right on a public road must, before reaching the point at which he or she intends to turn or move to the right, extend his or her right arm and hand sideward from the shoulder and fully horizontal to the road with the palm of the hand turned to the front.

REGULATIONS
Road Traffic and Transport Act 22 of 1999
Road Traffic and Transport Regulations, 2001

Signal to indicate intention to reduce speed

362. Subject to the provision of regulation 358(2)(d), the driver of a vehicle on a public road who intends to stop or to reduce speed suddenly must before doing so extend his or her right arm sideward from the shoulder with the forearm held in a vertical and upward position and the palm of the hand turned to the front, but this regulation does not apply to the driver of a vehicle fitted with a stop lamp complying with regulation 186.

Permissible hand signals

363. Subject to regulation 358(2)(d), the driver of a vehicle may, in addition to the signals prescribed in the preceding regulations, give the following hand signals:

- (a) If he or she intends to slow down, he or she may extend his or her right arm sideward from the shoulder with the palm of the hand turned downward and move his or her arm slowly up and down; or
- (b) if he or she desires to indicate to following traffic that it may overtake his or her vehicle on the right, he or she may fully extend his or her right arm below the level of the shoulder with the palm of the hand turned forward and move it backward and forward from the shoulder.

Signals for use by traffic officer for control of traffic

364. (1) The signals which a traffic officer must use for the control of traffic, are set out in Schedule 2, but a traffic officer is not prohibited from giving any other signal he or she considers appropriate in the exercise of his or her powers.

(2) A traffic officer who has given a stop signal to a driver of a vehicle or a pedestrian on a public road, may lower the hand by which such signal was given or use it for giving other signals and any such driver or pedestrian may not proceed until such officer signals to him or her to do so.

PART 3 **GENERAL**

Towing of vehicles

- 365.** A person may not operate on a public road a vehicle towing another vehicle -
- (a) if the length of the tow-rope, chain or tow-bar between the two vehicles exceeds three and a half metres, measured from the rear end of the towing vehicle to the front end of the vehicle being towed;
 - (b) if the towed vehicle is connected to the towing vehicle in such a manner that both vehicles are not under control;
 - (c) except, in the case of a towed vehicle fitted with steering mechanism contemplated in regulation 219(1), if such steering mechanism is controlled by a person holding a code of driving licence authorising him or her to drive the class of vehicle being towed, but this paragraph does not apply in the case where -

REGULATIONS
Road Traffic and Transport Act 22 of 1999
Road Traffic and Transport Regulations, 2001

- (i) the steerable wheels of the towed vehicle are being carried clear of the ground; or
- (ii) the device connecting the towing vehicle to the towed vehicle is such that the steerable wheels of the towed vehicle are controlled by such device;
- (d) if the brakes of the towed vehicle are defective in terms of regulation 171, unless the towing vehicle is connected to the towed vehicle by means of a drawbar or tow-bar;
- (e) at a speed in excess of 30 kilometres per hour, unless the towing vehicle is connected to the towed vehicle by means of a drawbar or a tow-bar;
- (f) if the towed vehicle is conveying persons at a speed in excess of 30 kilometres per hour, unless the towed vehicle is a semi-trailer; or
- (g) if the towing vehicle is a motorcycle or pedal cycle.

CHAPTER 9
MISCELLANEOUS

Matters relating to registers and records

- 366.** (1) The Minister shall -
- (a) keep a register of -
 - (i) authorised officers;
 - (ii) registering authorities;
 - (iii) manufacturers, builders and importers;
 - (iv) number plate manufacturers;
 - (v) inspectorate of manufacturers, builders, importers and number plate manufacturers;
 - (vi) driving testing centres;
 - (vii) inspectorate of driving testing centres;
 - (viii) vehicle testing stations;
 - (ix) inspectorate of vehicle testing stations;
 - (x) offenders convicted in terms of the Act;
 - (xi) standard publications incorporated into these regulations in terms of section 94 of the Act, including any restriction on those publications referred to in regulation 376;
 - (xii) cross-border permits issued by him or her;

REGULATIONS
Road Traffic and Transport Act 22 of 1999
Road Traffic and Transport Regulations, 2001

- (xiii) any incident reported to him or her in relation to the transportation of dangerous goods;
- (xiv) exemptions granted by him or her in terms of these regulations;
- (xv) notices published in the *Gazette* by him or her;
- (xvi) determinations made by him or her in terms of these regulations;
- (xvii) approvals granted by him or her in terms of these regulations;
- (b) retain on a register referred to in paragraph (a), such information contained on any form completed in terms of the regulations, as he or she may deem necessary for the purpose of the enforcement of the Act.
- (2) A driving testing centre must -
 - (a) keep record of -
 - (i) all applications made to that testing centre in terms of regulations 113,116,120,124, 126 and 128;
 - (ii) all tests and examinations conducted at that testing centre and the results thereof; and
 - (iii) all licences issued by that testing centre; and
 - (b) summarise on a monthly basis the results of all applications, examinations and tests conducted and licences issued and provide copies of such summary to -
 - (i) the Minister; and
 - (ii) the inspectorate of driving testing centres.
- (3) A vehicle testing station must -
 - (a) update the register of motor vehicles with regard to -
 - (i) all applications made to that vehicle testing station in terms of regulation 154;
 - (ii) all tests and examinations conducted at that vehicle testing station; and
 - (iii) all roadworthy certificates issued by that vehicle testing station;
 - (b) summarise on a monthly basis the results of all applications, examinations and testing conducted and provide copies of such summary to -
 - (i) the Minister; and
 - (ii) the inspectorate of testing stations; and

REGULATIONS
Road Traffic and Transport Act 22 of 1999
Road Traffic and Transport Regulations, 2001

- (c) reconcile on a monthly basis the number of tests conducted, the number of tests passed, the number of roadworthy certificates issued and the stock of such certificates in the possession of that testing station and provide such reconciliation to the Minister.
- (4) A manufacturer, builder or importer must keep a record of every motor vehicle manufactured, built or imported by that manufacturer builder or importer.
- (5) A number plate manufacturer must keep a register as contemplated in regulation 79(2).
- (6) A registering authority must keep a register of -
 - (a) motor vehicles, which must record, amongst others, particulars of every motor vehicle registered and licensed by it and every motor trade number and temporary and special permit issued by it;
 - (b) operators registered by it.
- (7) The Namibian Police must -
 - (a) keep a register of -
 - (i) Police clearances issued with regard to any motor vehicle;
 - (ii) temporary authorisations contemplated in section 31(2) of the Act;
 - (iii) all chassis numbers issued in terms of regulation 9 1(4);
 - (b) forward the particulars of the registers referred to in paragraph (a) to the Minister once a month.
- (8) An issuing authority or person appointed by the Minister to issue personalised licence numbers must keep a register of all personalised licence numbers issued by that issuing authority or person.
- (9) Any organ of State or institution which receives an admission of guilt fine paid to it by an offender in terms of the Criminal Procedure Act, 1977(Act No. 51 of 1977) for an offence committed in terms of the Act or regulations made by a local authority council or regional council in terms of section 92 of the Act, must forward a record of the admission of guilt to the Minister once a month.
- (10) Final disposition of the records contemplated in this regulation must be in accordance with the Archives Act, 1992 (Act No. 12 of 1992).

Vintage motor vehicles

- 367.** (1) A vintage motor vehicle is exempt from any provision of Part 3 of Chapter 5 of these regulations in so far as the fitment of the equipment required in terms of that Part will alter the original design and equipment of the motor vehicle.
- (2) If a number plate referred to in regulation 48 cannot be affixed to a vintage motor vehicle, a smaller number plate may be affixed.

REGULATIONS
Road Traffic and Transport Act 22 of 1999
Road Traffic and Transport Regulations, 2001

Seizure

368. If a traffic officer or road transport inspector exercises the power conferred on him or her in terms of section 107 of the Act, the Criminal Procedure Act, 1977, relating to the seizure, safekeeping and disposal of a seized article applies, adapted as contextually may be necessary, and any reference in that Act to “article” may be construed as a reference to a “motor vehicle and its load”.

Offences and penalties

369. (1) Any person who contravenes or fails to comply with these regulations or a direction given or condition imposed in terms hereof, is guilty of an offence and liable on conviction -

- (a) in the case of -
 - (i) regulation 240 (Overall length of vehicle);
 - (ii) regulation 242 (Overall width of vehicle);
 - (iii) regulation 243 (Overall height of vehicle and load);
 - (iv) regulation 244 (Turning radius and wheelbase);
 - (v) regulation 245 (Overhang of vehicle);
 - (vi) regulation 246 (Projections in case of vehicle other than motorcycle or pedal cycle);
 - (vii) regulation 247 (Projections in case of motorcycle or pedal cycle);
 - (viii) regulation 248 (Warning in respect of projecting load);
 - (ix) regulation 251 (Mass of persons and luggage for determining mass of load);
 - (x) regulation 252 (Number of persons that may be carried on motor vehicle in relation to seating capacity);
 - (xi) regulation 253 (Permissible maximum axle mass load of vehicle);
 - (xii) regulation 254 (Permissible maximum axle unit mass load of vehicle);
 - (xiii) regulation 255 (Permissible maximum vehicle mass);
 - (xiv) regulation 256 (Permissible maximum combination mass);
 - (xv) regulation 257 (Load on tyres);
 - (xvi) regulation 258 (Gross vehicle mass, gross axle mass load, gross axle unit mass load, gross combination mass, power/mass ratio and axle mass load of driving axle/total mass ratio not to be exceeded);

REGULATIONS
Road Traffic and Transport Act 22 of 1999
Road Traffic and Transport Regulations, 2001

- (xvii) regulation 259 (Mass load carrying capacity of road);
- (xviii) regulation 260 (Mass load carrying capacity of bridges);
- (xix) regulation 261 (Distribution of axle mass load and wheel mass load on vehicle fitted with pneumatic tyres);
- (xx) regulation 262 (Axle mass loads of vehicles fitted with tyres other than pneumatic tyres);
- (xxi) regulation 265 (Manner in which goods to be carried); and
- (xxii) regulation 266 (Circumstances under which persons may be carried on goods vehicle),

to a fine not exceeding N\$ 20 000 or imprisonment for a period not exceeding two years or both such fine and such imprisonment; or

- (b) in the case of any other regulation, to a fine not exceeding N \$4 000 or imprisonment for a period not exceeding one year or both such fine and such imprisonment.

(2) If a prosecution is instituted as a result of an offence committed in terms of the Act and these regulations, the approved form may be used.

Apportionment of fees

370. All fees paid in terms of the Act, other than fees determined by the Road Fund Administration in terms of the Road Fund Administration Act, 1999, may be administered as determined by the Minister.

Licence inspector, traffic officer or road transport inspector entitled to free use of certain facilities

371. Until a date determined by the Minister for the implementation of a payment system, a local authority may not require a licence inspector, traffic officer or road transport inspector, in the performance of his or her duties, to pay for the use of any testing facility or weighing device provided by it.

Officer to use approved forms

372. A licence inspector or a traffic officer who -

- (a) issues a receipt for the impoundment of a document in terms of section 13 of the Act; or
- (b) demands the production of a document in terms of section 13 or 14 of the Act,

as the case may be, must use the approved form.

Application for and issue of traffic register number and certificate

REGULATIONS
Road Traffic and Transport Act 22 of 1999
Road Traffic and Transport Regulations, 2001

373. (1) An application for a traffic register number must be made to the appropriate registering authority, on the approved form and must be accompanied by -

- (a) in the case of a body of persons, acceptable identification of the-natural persons nominated as the representative, the proxy and the signee of the application and a form of proxy; or
- (b) in the case of a natural person not permanently resident in Namibia, a temporary identity certificate, an unexpired passport or a temporary permit or other document of identity of a class recognised by the Minister of Home Affairs in terms of the legislation regulating the admission of persons to Namibia.
- (c) in the case of a natural person being a Namibian citizen or who holds a permanent residence permit issued under the Immigration Control Act, 1993 (Act No. 7 of 1993) who is not in possession of an identity document issued or deemed to have been issued under Identification Act, 1996 (Act No. 21 of 1996) -
 - (i) a birth certificate;
 - (ii) a proof of registration issued under section 6 of the Identification Act, 1996 or a passport or other travel document prescribed under section 10(1)(b) of that Act.

[paragraph (c) inserted by GN 163/2002]

(2) The registering authority referred to in subregulation (1) must, if satisfied that the application is in order, allocate a traffic register number to the applicant and issue a traffic register number certificate on the approved form.

(3) If any of the particulars submitted in the application referred to in subregulation (1) or contained in the traffic register number certificate, change, the holder thereof must, within 21 days after that change, notify the appropriate registering authority on the approved form and subregulation (2) applies with the necessary changes.

(4) If a person or body of persons who is the holder of a traffic register number certificate, becomes the holder of any other document referred to in the definition of “acceptable identification” that person or body of persons must, within 21 days after becoming such holder, notify the appropriate registering authority referred to in subregulation (1) thereof on the approved form and must at the same time submit such document together with the traffic register number certificate to that registering authority.

(5) The registering authority must, if satisfied that the notification referred to in subregulation (4) is in order, cancel the traffic register number certificate and amend its records accordingly.

Proxy

374. A person carrying on a business or a body of persons, must identify at least one proxy in respect of each branch of such business or body of persons and for the purpose of this regulation a business includes any farming activity.

Prohibition against the use of certain lamps or lighting devices

REGULATIONS
Road Traffic and Transport Act 22 of 1999
Road Traffic and Transport Regulations, 2001

375. (1) A person may not use a lamp or lighting device in such a manner that the visibility of such lamp or lighting device from a public road, endangers public safety.

- (2) This regulation does not apply to lamps and lighting devices that are used -
- (a) on a motor vehicle;
 - (b) in accordance with any law;
 - (c) by the State or any other statutory body, in the execution of its functions, powers and duties; or
 - (d) under a written authorisation issued by the local authority concerned.

(3) Lamps and lighting devices which are in use in contravention of subregulation (1) at the date of commencement of this regulation, may be so used until such time as the local authority concerned directs that it be removed or altered in terms of subregulation (5) in which event the cost of such removal or alteration must be borne by the persons so using the lamps or lighting devices.

(4) A local authority may authorise the use of a lamp or lighting device which is visible from a public road under the conditions and for the period determined by the local authority and that authorisation may be altered or revoked at any time by that local authority.

(5) If a local authority is satisfied that a lamp or lighting device is used in contravention of this regulation, the local authority may by written notice direct the person so using that lamp or lighting device, to alter or remove that lamp or lighting device at his or her cost within the period determined by that local authority which period may not be less than 14 days.

(6) If a direction in terms of subregulation (5) has not been complied with within the period referred to in that subregulation, the local authority concerned may remove or alter the lamp or lighting device concerned and recover the cost of the removal or alteration from the person using that lamp or lighting device.

(7) For the purposes of this regulation, a lamp or lighting device is deemed to be used by the person on whose property the lamp or lighting device has been erected.

Standard publications incorporated in terms of section 94 of the Act

376. (1) The standards publications incorporated into these regulations in terms of section 94 of the Act are available for free inspection during office hours at the offices of the Deputy Permanent Secretary of Transport or at the Namibia Standards Institution (NSI).

[subregulation (1) substituted by GN 98/2016]

(2) The Minister may by notice in the *Gazette*, restrict the application of a standard publication for the purposes of these regulations.

Persons having access to registers to be registered

REGULATIONS
Road Traffic and Transport Act 22 of 1999
Road Traffic and Transport Regulations, 2001

377. (1) Any person or authority who has to keep a register in terms of section 95 of the Act or regulation 366, must register any person who has access to that register as an authorised user.

(2) The Minister, in consultation with the person or authority referred to in subregulation (1), must publish a code of conduct for the authorised users registered in terms of this regulation.

(3) If an alleged contravention of the code of conduct for authorised users comes to the attention of the Minister, the Minister must consider the revocation of the registration of authorised user concerned.

(4) The Minister shall, in considering the revocation of the registration of a registered person -

(a) notify the authorised user concerned; and

(b) inform the authorised user concerned that he or she may submit to the Minister in writing, within 14 days after that notification, any aspect that may be taken into account in considering the revocation.

(5) If the Minister revokes the registration of an authorised user, he or she must -

(a) notify that authorised user of the reason for the revocation; and

(b) ensure that the register of authorised users is updated accordingly.

(6) If the registration of an authorised user has been revoked that authorised user may not access any register kept in terms of the Act or these regulations after the revocation.

Appeal procedure

378. (1) An authorised user whose registration has been suspended or revoked and who feels aggrieved by the revocation of his or her registration, may, within 21 days after he or she has been informed of the revocation, in writing appeal against that revocation to the Commission and the appellant must at the same time serve a copy of the appeal on the Minister.

(2) After receipt of the copy of the appeal referred to in subregulation (1) the Minister must forthwith furnish the Commission with the reasons for the revocation to which the appeal relates.

(3) For the purpose of deciding an appeal lodged in terms of subregulation (1), the Commission may require each party to the appeal to furnish such information or evidence, as it considers necessary.

(4) The Commission may, after due consideration of the appeal, restore the registration of the appellant or confirm the revocation of the registration.

Procedure for hearings

379. (1) If the Minister conducts a hearing in terms of regulations 9, 75, 76, 80, 108, 141, 150, 162 or 289, he or she must follow the procedures prescribed in this regulation.

REGULATIONS
Road Traffic and Transport Act 22 of 1999
Road Traffic and Transport Regulations, 2001

[The plural word “regulations” should be the singular word “regulation”.]

(2) The Minister must appoint a presiding officer, who is qualified in law to preside at a hearing in terms of this regulation and an investigating officer, who must investigate any allegation brought to the attention of the Minister in terms of regulation 9, 75, 76, 80, 108, 141, 150, 162 or 289.

(3) The investigating officer may, for the purpose of a hearing, subpoena any person who in his or her opinion may be able to give material information concerning the subject of the hearing, or who he or she suspects or believes has in his or her possession or custody or under his or her control any book, document or object which has any bearing on the subject of the hearing, to appear before the presiding officer at the time and place specified in the subpoena, to be questioned or to produce that book, document or object.

(4) A subpoena to a person to appear before the presiding officer or to produce a book, document or object, must be signed by the presiding officer and be served on that person by delivering or tendering it to him or her or by sending it by registered mail to him or her.

(5) The investigating officer may retain a book, document or object so produced, for the duration of the hearing.

(6) During a hearing an investigating officer may -

(a) lead evidence and advance arguments in support of the charge and cross-examine witnesses; and

(b) question any person who was or might have been subpoenaed in terms of subsection (1) and order him or her to produce any book, document or object in his or her possession or custody or under his or her control which the investigating officer suspects or believes to have a bearing on the subject of the hearing.

(7) The presiding officer may administer an oath to or accept an affirmation from any person present at the hearing who was or might have been subpoenaed in terms of subregulation (3).

(8) A person who has been subpoenaed -

(a) may not without sufficient cause, fail to attend the hearing at the time and place specified in the subpoena;

(b) must remain in attendance until excused by the presiding officer from further attendance;

(c) may not refuse to be sworn in or to be affirmed as a witness;

(d) may not, without sufficient cause, fail to answer fully and satisfactorily to the best of his or her knowledge to all questions lawfully put to him or her;

(e) may not fail to produce any book, document or object in his or her possession which he or she has been required to produce.

(9) The law relating to privilege, as applicable to a witness subpoenaed to give evidence or to produce a book, document or object in a civil trial before a court of law, applies,

REGULATIONS
Road Traffic and Transport Act 22 of 1999
Road Traffic and Transport Regulations, 2001

adjusted as may contextually be necessary, in relation to the examination of, or the production of any book, document or object to the presiding officer, by any person called in terms of this section as a witness.

(10) A person may not, after having been sworn in or having been affirmed as a witness, give a false statement on any matter, knowing that answer or statement to be false.

(11) A person may not prevent another person from obeying a subpoena issued under subsection (1), or from giving evidence or producing a book, document or object which he or she is in terms of this section required to give or produce.

(12) If the conduct with which a person is charged amounts to an offence of which he or she has been convicted by a court of law, a certified copy of the record of his or her trial and conviction by that court is, on the identification of the registered person as the person referred to in the record, sufficient proof of the commission by him or her of such offence, unless the conviction has been set aside by a superior court.

(13) At a hearing the person charged has the right -

(a) to be personally present, to be assisted or represented by another person, to give evidence and, either personally or through a representative -

(i) to be heard;

(ii) to call witnesses;

(iii) to cross-examine any person called as a witness in support of the charge; and

(iv) to have access to documents produced in evidence;

(b) despite the fact that he or she denied the charge, to admit at any time after that denial, that he or she is guilty of the charge, whereupon he or she will be deemed to be guilty as charged;

(c) if the conduct with which he or she is charged amounts to an offence of which he or she was convicted by a court of law, to show cause why in his or her opinion he or she was wrongly convicted.

(14) After the conclusion of the hearing the presiding officer must make a finding on the charge, and, in the case of a finding of guilty, take cognisance of any aggravating or mitigating circumstances it may find.

(15) (a) If the person or institution charged is found guilty as charged, or if he or she admits that he or she is guilty of the charge, the presiding officer -

(i) must, where that person or institution is registered in terms of the Act, recommend the deregistration of the person or institution to the Minister; and

(ii) may, in addition to the recommendation to the Minister in terms of subparagraph (i), impose on the person or institution a fine not exceeding N\$ 24 000.00.

REGULATIONS
Road Traffic and Transport Act 22 of 1999
Road Traffic and Transport Regulations, 2001

- (b) The presiding officer may take decisions under more than one of the subparagraphs of paragraph (a), but in the case of a contravention by a driving testing centre, a vehicle testing station, a manufacturer, builder or importer or a manufacturer of number plates, a decision in terms of subparagraphs (i) and (ii) may not be entertained.

(16) The presiding officer shall notify the person charged of its finding and of the person's right of appeal in terms of the applicable provision of the Act or these regulations.

CHAPTER 10
TRANSITIONAL PROVISIONS

Schedule to regulate certain matters

380. Until a date determined by the Minister by notice in the *Gazette*, motor dealers' licences, the fitness of drivers, public motor vehicles and roadworthiness are regulated by the applicable Schedule.

Presumption with regard to Schedule

381. Any reference in any document, including a charge sheet in terms of the Criminal Procedure Act, 1977, relating to a provision in the repealed Ordinance with regard to motor dealers' licences, the fitness of drivers, public motor vehicles and roadworthiness is deemed to be a reference to the corresponding provision in the applicable Schedule.

Title-holder and owner same person

382. Until a date determined by the Minister in the *Gazette*, the owner of a motor vehicle must assume the duties of the title-holder of that motor vehicle.

Period of validity of driving licence for transitional period

383. (1) For a period of three years after the date commencement of this regulation, a driving licence may, despite regulation 111, be issued for a period of less than five years, depending on the date on which the driving licence was ordered from the card producing facility, but the period of validity may not be less than three years.

(2) If a driving licence is issued for less than five years in terms of subregulation (1), the fee payable in terms of Schedule 1 for the issue of a driving licence card must be adjusted proportionally.

[regulation 383 deleted by GN 97/2001 and inserted by GN 163/2002]

Interim Procedure for the exchange of a driving licence contained in South African identity document

[The word "procedure" in the heading should not be capitalised.]

383A.(1) Notwithstanding regulation 383, an application for the exchange of a driving licence issued in Namibia in terms of the repealed Ordinance of which a Namibian citizen or a person who is permanently resident in Namibia is the holder and which is contained in an identity document issued by the South African Government in accordance with the laws of that

REGULATIONS
Road Traffic and Transport Act 22 of 1999
Road Traffic and Transport Regulations, 2001

country, may, from the date determined by the Minister in terms of section 40 of the Act, be made to any driving testing center on the approved form.

(2) An application for the exchange of a driving licence referred to in sub-regulation (1) must be accompanied by -

- (i) the original driving licence as contained in that identity document;
- (ii) the acceptable identification of the applicant;
- (iii) the fee prescribed for the issue of a driving licence in terms of Schedule 1 of the Regulations.

(3) If the driving testing center is satisfied with regard to the identity of the holder of the driving licence concerned, it must issue to the applicant a driving licence of the corresponding code contemplated in Schedule 4 to these Regulations.

[Regulation 383A is inserted by GN 103/2002. The date determined by the Minister in terms of section 40 of the Act, referred to in subregulation (1), is 1 July 2002 (GN 102/2002, [GG 2759](#)).]

Transitional provision in relation to public driving permit

383A. Notwithstanding the repeal of items 13 to 21 of Schedule 5 and the commencement of regulation 127 of the Regulations, a person who was not obliged in terms of those items to obtain a public driving permit and who holds a licence of a code which, in terms of regulation 127, is required to be endorsed in accordance with the provisions of that regulation, is, until the date applicable to him or her in terms of the notice issued by the Minister in terms of section 40(1) of the Act, deemed to comply with regulation 127.

[A second version of regulation 383A is inserted by GN 163/2002, with no comment about the previous insertion of section 383A.]

Owner deemed to be operator

384. Until the owner or the person contemplated in section 60(5) of the Act is registered as the operator in respect of a motor vehicle referred to in regulation 284, the owner of the motor vehicle is deemed to be the operator of that motor vehicle.

Inspectorates

385. Until such time as the Minister designates a person, authority or organisation as an inspectorate of manufacturers, builders, importers or number plate manufacturers, inspectorate of driving testing centres or inspectorate of vehicle testing stations, he or she may exercise the powers and duties assigned to those inspectorates in terms of the Act.

Authorised officers and authorised users

386. Any person who, at the date of commencement of these regulations, is employed as an authorised officer or authorised user and who is registered as such for the first time in terms of regulation 2 or regulation 377, is exempt from the payment of registration fees.

Short title

REGULATIONS
Road Traffic and Transport Act 22 of 1999
Road Traffic and Transport Regulations, 2001

387. These regulations are called the Road Traffic and Transport Regulations, 2001.

REGULATIONS
Road Traffic and Transport Act 22 of 1999
Road Traffic and Transport Regulations, 2001

SCHEDULE 1
 MISCELLANEOUS FEES

[Schedule 1 is amended by GN 163/2002, substituted by GN 205/2004, amended by GN 32/2005, substituted by GN 45/2005 and by GN 104/2007, amended by GN 172/2007 (which substitutes items 28 and 29) and substituted by GN102/2020.]

Item No	Transaction	Fee-N\$	Empowering provision
1.	Application for registration as authorised officer	35.00	Regulation 4
2.	Issue of registration certificate to an authorised officer	30.00	Regulation 6
3.	Allocation of specific licence number	600.00	Regulation 36
4.	Transfer of licence number to own vehicle	80.00	Regulation 36A
5.	Transfer of licence number to vehicle of other owner	600.00	Regulation 38A
6.	Allocation of personalised licence number, including the manufacture of licence plates	2 000.00	Regulation 39
7.	Duplicate personalised licence number, per plate	240.00	Regulation 39
8.	Transfer of personalised licence number	80.00	Regulation 39E
9.	Annual renewal of personalised licence number	280.00	Regulation 40
10.	Application for registration as manufacturer, builder or importer	30.00	Regulation 73
11.	Application for registration as number plate manufacturer	200.00	Regulation 78
12.	Registration as manufacturer, builder, importer or number plate manufacturer	600.00	Regulation 83(1)
13.	Fee per motor vehicle design	600.00	Regulation 83(2)
14.	Issue of chassis or engine number	80.00	Regulation 91
15.	Issue of duplicate document or token	30.00	Section 91(2)(xxv) of the Act
16.	Cost of confirming information per item	50.00	Regulation 99
17.	Application for registration as driving testing center	200.00	Regulation 102
18.	Application for learner's licence (including test)	45.00	Regulation 113
19.	Issue of learner's licence	50.00	Regulation 115
20.	Application for driving licence code A1, A, B, BE	160.00	Regulations 116, 118, 120, 121, 123, 124, 126 and 132
21.	Application for driving licence code C1, C, C1E, CE	160.00	Regulations 116, 118, 120, 121, 123, 124, 126 and 132
22.	Application for professional authorisation	110.00	Regulation 128
23.	Issue of driving licence card of any code	200.00	Regulation 118
24.	Duplicate driving licence	200.00	Regulation 120 and 115

REGULATIONS
Road Traffic and Transport Act 22 of 1999
Road Traffic and Transport Regulations, 2001

25.	Application for temporary driving licence	50.00	Regulation 123
26.	Application for instructor's certificate (including examination)	200.00	Regulation 138
27.	Issue of instructor's certificate	100.00	Regulation 138
28.	Application for registration as vehicle testing station	150.00	Regulation 144
29.	Application for certification of roadworthiness (including test)	150.00	Regulation 154
30.	Issue of roadworthy certificate	100.00	Regulation 158 read with regulation 156
31.	Notification of identity of operator	40.00	Regulation 286
32.	Application for duplicate operator card	30.00	Regulation 286
33.	Registration as authorised user	20.00	Regulation 3777 [This should be regulation "377".]

SCHEDULE 2

ROAD TRAFFIC SIGNS

Definitions

For the purposes of this Schedule, unless the context otherwise indicates -

“abnormal vehicle” means any vehicle which is operated under a written exemption granted in terms of section 99 of the Act;

“agricultural vehicle” means a vehicle designed or adapted solely for agricultural activities and includes a tractor but does not include a goods vehicle;

“authorised vehicle” means any motor vehicle identified by means of -

- (a) a number plate;
- (b) an authorised symbol or name on the vehicle; or
- (c) an authorised disc affixed to the inside of the windscreen of the vehicle.

and the identification of which is thereby compatible with that displayed on the appropriate road traffic sign by a competent authority;

“construction vehicle” means any vehicle used in connection with construction and maintenance of roads and buildings;

“delivery vehicle” means a goods vehicle or motor cycle in the process of being loaded or unloaded;

“hawker” means a person who sells or trades goods;

REGULATIONS
Road Traffic and Transport Act 22 of 1999
Road Traffic and Transport Regulations, 2001

“high occupancy vehicle” means a motor vehicle, means a motor vehicle in which the number of occupants equals or exceeds the number indicated on an appropriate road traffic sign;

“midibus” means a bus which is designed or adapted solely for the conveyance of not more than 35 persons, excluding the driver;

“mini circle” means a type of small traffic circle, entry to which is controlled by road traffic sign R2.2;

“painted island” means an island marked on the road surface that serves as a channelling device with a junction or in a public road;

“rickshaw” means a vehicle with two wheels designed to be pulled by a person;

“taxi” means a motor car, motor tricycle or motor quadrucycle which is designed or adapted for the conveyance of up to nine persons, including the driver, and is operating for reward;

“tour bus” means a minibus, midibus or bus which is operated by or leased to a tour operator and which is solely or principally used to convey tourists;

“traffic circle” means a junction which contains a traffic or painted island, around which a road user travels in a clockwise direction;







“tram” means a device that operates on rails within a public road;

“variable message sign” means a road traffic sign which is capable of varying its message by manual or remote control to display a different message to the message last displayed and the road traffic sign may be light reflecting or light emitting;

“zig-zag-zone” means that section of a roadway delineated by a zig-zag zone marking line marking RM 11.

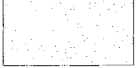
[The hyphen between “zig-zag” and “zone” in the first use of that phrase in the definition is superfluous.]

Key to Colour Coding

White			Black
Red			Yellow
Brown			Blue
Green			Orange

REGULATIONS
Road Traffic and Transport Act 22 of 1999
Road Traffic and Transport Regulations, 2001

CLASS I: ROAD SIGNS

Regulatory Signs

Regulatory signs are classified as follows:

- A Control signs
- B Command signs
- C Prohibition signs
- D Reservation signs
- E Comprehensive signs
- F Exclusive secondary signs
- G Derestriction signs
- II Examples of selective restriction regulatory signs
- I Examples of regulatory sign combinations

A. Control Signs:

R1 : Stop sign:

R1

COLOURS:

Border & legend: White retro-reflective
 Background: Red retro-reflective
 Back of sign: White semi-matt



- (a) Indicates to the driver of a vehicle that he or she shall stop his or her vehicle with its front end in line with that sign, or if stop line RTM1 is used in conjunction with that sign, immediately behind that stop line, and that such driver may not proceed until it is safe to do so.
- (b) This sign must also be used for the purpose of a scholar patrol referred to in section 74(4) of the Act and -
 - (i) while it is suspended over the roadway at right angles to the kerb line by a member of a scholar patrol, indicates, in addition to its ordinary significance, that the driver of a vehicle shall stop that vehicle in front thereof or immediately behind the yield line RTM2 in conjunction with which that sign is used, and remain stationary until the sign is no longer displayed;
 - (ii) must be portable and so suspended on a lightweight pole that there is a stop sign R1 displayed in both directions;
 - (iii) two signs, one each side of the roadway, must be displayed.
- (c) This sign may also be used at a railway crossing and, when so used, it must be used in conjunction with the appropriate railway warning signs W403 and W404.
- (d) This sign may also be used in conjunction

REGULATIONS
Road Traffic and Transport Act 22 of 1999
Road Traffic and Transport Regulations, 2001

with an appropriate supplementary plate sign EN11 if the driver of a vehicle is required to stop by a traffic officer or custom official and must in addition to its ordinary significance, indicate that the driver of a vehicle may not proceed until directed to do so by a traffic officer or a customs official.

R1.2 : Stop/Yield sign:

COLOURS:

Stop segment
 Border & legend: White retro-reflective
 Background: Red retro-reflective
 Back of sign: White semi-matt

Yield segment
 Outer border: White retro-reflective
 Inner border: Red retro-reflective
 Background: White retro-reflective
 Arrow: Black semi-matt
 Back of sign: White semi-matt

Indicates to the driver of a vehicle approaching a junction who intends to -
 (a) proceed straight-on or to the right at the junction, that such driver shall act as for stop sign R1; or
 (b) proceed to the left at the junction that such driver shall yield right-of-way to all vehicular traffic approaching from his or her right, where that traffic is so close as to constitute a danger or potential danger.

R1.2

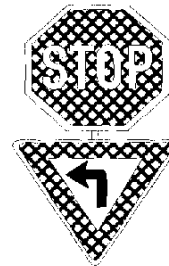

R1.3 : 3-Way stop sign:

COLOURS:

Border & legend: White retro-reflective
 Background: Red retro-reflective
 Back of sign: White semi-matt

Indicates to the driver of a vehicle approaching a 3-way stop sign, that he or she shall act as for stop sign R1, and he or she may not proceed into the junction, until every vehicle which has stopped at any other stop line at that junction before him or her and which would, in the normal course of events, cross the path of that driver's vehicle, has cleared the junction.

R1.3

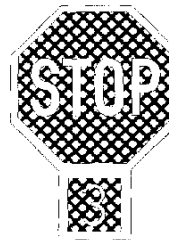

REGULATIONS
Road Traffic and Transport Act 22 of 1999
Road Traffic and Transport Regulations, 2001

R1.4 : 4-Way stop sign:

COLOURS:

Border & legend: White retro-reflective
 Background: Red retro-reflective
 Back of sign: White semi-matt

Indicates to the driver of a vehicle approaching a 4-way stop sign that he or she shall act as for stop sign R1, and he or she may not proceed into the junction until every vehicle which has stopped at any other stop line at that junction before him or her and which would, in the normal course of events, cross the path of that driver's vehicle, has cleared the junction.

R1.4

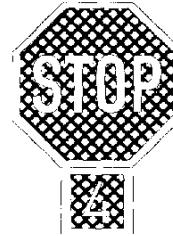

R1.5 : Stop/Go sign:

COLOURS:

Stop side
 Border & legend: White retro-reflective
 Background: Red retro-reflective

Go side
 Border & legend: Black semi-matt
 Background: Yellow retro-reflective

Indicates to the driver of a vehicle that -
 (a) he or she shall act as for stop sign R1 when "STOP" is displayed; and
 (b) if "GO" is displayed, he or she shall proceed with caution.

R1.5



R2 : Yield sign:

COLOURS:

Outer border: White retro-reflective
 Inner border: Red retro-reflective
 Background: White retro-reflective

Indicates to the driver of a vehicle approaching such sign that he or she shall yield right-of-way to all -

- (a) traffic on the roadway which is joined by the roadway on which he or she is travelling; or
- (b) rail traffic on the railway line which is crossed by the roadway on which he or she is travelling,

where such traffic is so close as to constitute a danger or potential danger.

R2

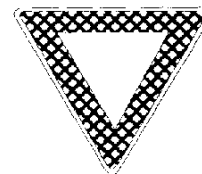

REGULATIONS
Road Traffic and Transport Act 22 of 1999
Road Traffic and Transport Regulations, 2001

R2.1 : Yield to pedestrian sign:

COLOURS:

Yield segment
Outer border: White retro-reflective
Inner border: Red retro-reflective
Background: White retro-reflective

Pedestrian segment
Border & symbol: White retro-reflective
Background: Red retro-reflective

Indicates that the driver of a vehicle approaching such sign shall yield right-of-way to pedestrians crossing the roadway or waiting to cross the roadway.

R2.1

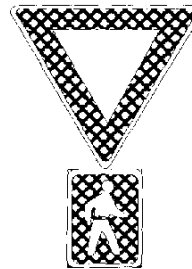

R2.2 : Yield at mini circle sign:

COLOURS:

Outer border: White retro-reflective
Inner border: Red retro-reflective
Arrows: Black semi-matt
Background: White retro-reflective

Indicates to the driver of a vehicle approaching a mini circle that he or she shall yield right-of-way to any vehicle which will cross any yield line at that junction before him or her and which, in the normal course of events, will cross the path of such driver's vehicle and that the driver shall move in a clockwise direction in such intersection and attempt not to encroach on the mini circle.

R2.2



R3 : No entry sign:

COLOURS:

Border & symbol: White retro-reflective
Background: Red retro-reflective

Indicates to the driver of a vehicle that the entry of all vehicular traffic is prohibited.

R3

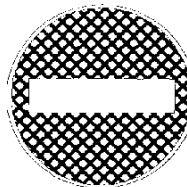

REGULATIONS
Road Traffic and Transport Act 22 of 1999
Road Traffic and Transport Regulations, 2001

R4 : One-way roadway sign:

R4

COLOURS:

Border & arrow: White retro-reflective
 Background: Red retro-reflective

Indicates to the driver of a vehicle who intends using the roadway concerned, that he or she shall drive on such roadway only in the direction indicated by the arrow.

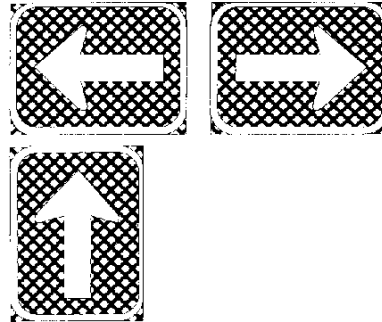

R5 : Pedestrian priority sign:

R5

COLOURS:

Border & symbol: White retro-reflective
 Background: Red retro-reflective

Indicates to the driver of a vehicle that only -
 (a) a vehicle, for the purpose of delivering or loading goods;
 (b) a vehicle used in connection with maintenance;
 or
 (c) an emergency vehicle,
 is permitted in an area set aside as a pedestrian precinct, marked by such sign and the driver of the vehicle contemplated in paragraph (a), (b) or (c) shall -
 (i) yield right-of-way to all pedestrians who are crossing or about to cross the vehicle's path;
 (ii) observe a maximum speed of 15 kilometres per hour unless another speed limit is indicated by a sign; and
 (iii) if he or she is delivering or loading goods, do so only in places marked for such purpose in that area.



R6: Yield to oncoming traffic sign:

R6

COLOURS:

Border: Red semi-matt
 Left arrow: Red retro-reflective
 Right arrow: Black semi-matt
 Background: White retro-reflective

Indicates to the driver of a vehicle that he or she shall yield to oncoming traffic and may only proceed when it is safe to do so.

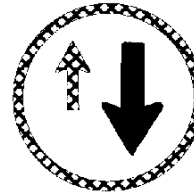

REGULATIONS
Road Traffic and Transport Act 22 of 1999
Road Traffic and Transport Regulations, 2001

B. Command Signs:

R101

R101 : Minimum speed sign:

COLOURS:

Border & legend: White retro-reflective
Background: Blue retro-reflective

Temporary sign number TR101.
Indicates to the driver of a vehicle on a public road that he or she shall maintain or exceed the minimum speed indicated in kilometres per hour by the number on such sign.

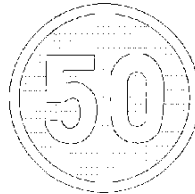

R102 : Vehicles exceeding mass only sign:

R102

COLOURS:

Border & legend: White retro-reflective
Background: Blue retro-reflective

Temporary sign number TR102.
Indicates to the driver of a vehicle that the use of the public road or portion of the public road is restricted to a vehicle with a gross vehicle mass (GVM) or gross combination mass (GCM) that exceeds that mass, indicated in tonnes by the number on such sign, and that the driver of that vehicle may only use such public road or portion of such public road designated by the sign.

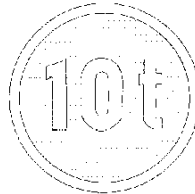

R103 : Keep left sign:
R104 : Keep right sign:

R103 and R104

COLOURS:

Border & arrow: White retro-reflective
Background: Blue retro-reflective

Temporary sign numbers TR103 and TR104.
Indicates to the driver of a vehicle that he or she may only pass to the left-hand side or the right-hand side, as indicated by the arrow, of an obstacle on the roadway on which a sign has been placed.

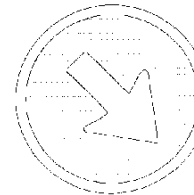
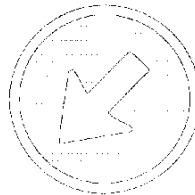

REGULATIONS
Road Traffic and Transport Act 22 of 1999
Road Traffic and Transport Regulations, 2001

R105 : Proceed left only sign:
R106 : Proceed right only sign:
R107 : Proceed straight only sign:

COLOURS:

Border & arrow: White retro-reflective
Background: Blue retro-reflective

Temporary sign numbers TR105, TR106 and TR107.

Indicates to the driver of a vehicle that he or she shall only proceed in the direction indicated by the arrow on such sign.

R105 and R106

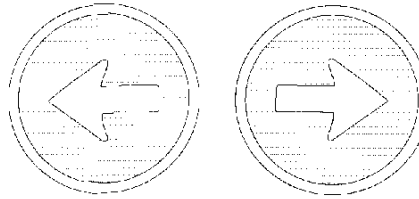

R107

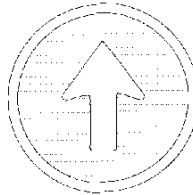

R108 : Turn left sign:
R109 : Turn right sign:

COLOURS:

Border & arrow: White retro-reflective
Background: Blue retro-reflective

Temporary sign numbers TR108 and TR109.
Indicates to the driver of a vehicle that he or she shall only proceed in the direction indicated by the arrow on such sign, at the junction ahead.

R108 and R109

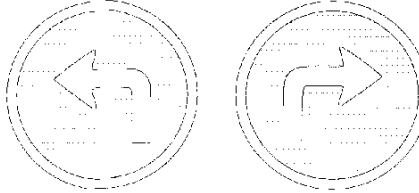

R110 : Pedestrians only sign:

COLOURS:

Border & symbol: White retro-reflective
Background: Blue retro-reflective

Temporary sign number TR110.
Indicates that the public road or a portion of the public road is set aside for pedestrians only, and that pedestrians shall only use that public road or portion of that public road.

R110

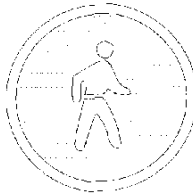

REGULATIONS
Road Traffic and Transport Act 22 of 1999
Road Traffic and Transport Regulations, 2001

R111 : Pedal cycles only sign:

COLOURS:

Border & symbol: White retro-reflective
Background: Blue retro-reflective

Temporary sign number TR111.
Indicates that the public road or a portion of the public road is set aside for use by pedal cyclists only, and that a pedal cyclist shall only use that public road or portion of that public road.

R111

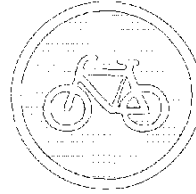

R112 - R115 : Pedal cycles and pedestrians only sign:

COLOURS:

Border & symbol: White retro-reflective
Background: Blue retro-reflective

Temporary sign numbers TR112, TR113, TR114 and TR115.

Indicates that the public road or a portion of the public road is set aside for use by pedal cyclists or pedestrians or both, and that the pedestrians or pedal cyclists or both shall only use that public road or portion of that public road as indicated by the applicable road traffic sign.

R112 and R113

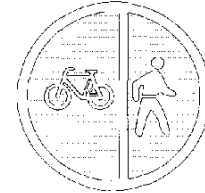
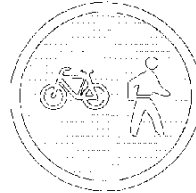

R114 and R115

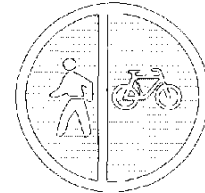
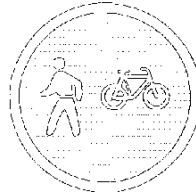

R116 : Motor cycles only sign:

COLOURS:

Border & symbol: White retro-reflective
Background: Blue retro-reflective

Temporary sign number TR116.
Indicates that the public road or a portion of the public road is set aside for use by motor cycles only, and that the driver of a motor cycle shall only use that public road or portion of that public road.

R116

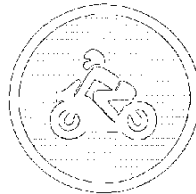

REGULATIONS
Road Traffic and Transport Act 22 of 1999
Road Traffic and Transport Regulations, 2001

R117 : Motor cars only sign:

COLOURS:

Border & symbol: White retro-reflective
Background: Blue retro-reflective

Temporary sign number TR117.
Indicates that the public road or a portion of the public road is set aside for use by motor cars only, and that the driver of a motor car shall only use that public road or portion of that public road.

R117

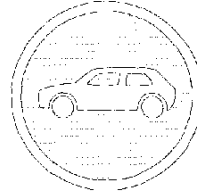

R118 : Taxis only sign:

COLOURS:

Border & symbol: White retro-reflective
Background: Blue retro-reflective

Temporary sign number TR118.
Indicates that the public road or a portion of the public road is set aside for use by taxis only, and that the driver of a taxi shall only use that public road or portion of that public road.

R118

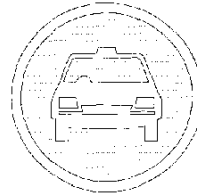

R119 : Minibuses only sign:

COLOURS:

Border & symbol: White retro-reflective
Background: Blue retro-reflective

Temporary sign number TR119.
Indicates that the public road or a portion of the public road is set aside for use by minibuses only, and that the driver of a minibus shall only use that public road or portion of that public road.

R119

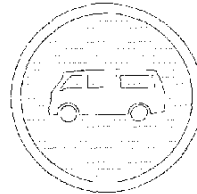

R120 : Midibuses only sign:

COLOURS:

Border & symbol: White retro-reflective
Background: Blue retro-reflective

Temporary sign number TR120.
Indicates that the public road or a portion of the public road is set aside for use by midibuses only, and that the driver of a midibus shall only use that public road or portion of that public road.

R120

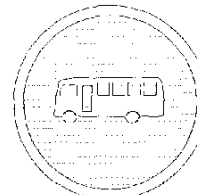

REGULATIONS
Road Traffic and Transport Act 22 of 1999
Road Traffic and Transport Regulations, 2001

R121 : Buses only sign:

COLOURS:

Border & symbol: White retro-reflective
Background: Blue retro-reflective

Temporary sign number TR121.
Indicates that the public road or a portion of the public road is set aside for use by buses only, and that the driver of a bus shall only use that public road or portion of that public road.

R121

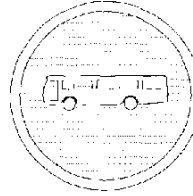

R122 : Delivery vehicles only sign:

COLOURS:

Border & symbol: White retro-reflective
Background: Blue retro-reflective

Temporary sign number TR122.
Indicates that the public road or a portion of the public road is set aside for use by delivery vehicles only, and that the driver of a delivery vehicle shall only use that public road or portion of that public road.

R122

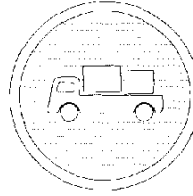

R123 : Goods vehicles only sign:

COLOURS:

Border & symbol: White retro-reflective
Background: Blue retro-reflective

Temporary sign number TR123.
Indicates that the public road or portion of the public road is set aside for use by goods vehicles only, and that the driver of such goods vehicle shall only use that public road or portion of that public road.

R123

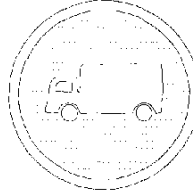

R124 : Goods vehicles over indicated GVM only sign:

COLOURS:

Border & symbol: White retro-reflective
Legend: Black semi-matt
Background: Blue retro-reflective

Temporary sign number TR124.
Indicates that the public road or a portion of the public road is set aside for use only by goods vehicles with a gross vehicle mass (GVM) or a gross combination mass (GCM) exceeding the mass indicated in tonnes on such sign, and that the driver of such goods vehicle shall only use that public road or portion of that public road.

R124

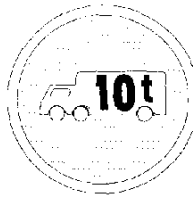

REGULATIONS
Road Traffic and Transport Act 22 of 1999
Road Traffic and Transport Regulations, 2001

R125 : Construction vehicles only sign:

COLOURS:

Border & symbol: White retro reflective
Background: Blue retro-reflective

Temporary sign number TR125.
Indicates that the public road or a portion of the public road is set aside for use by construction vehicles only, and that the driver of a construction vehicle shall only use that public road or portion of that public road.

R125

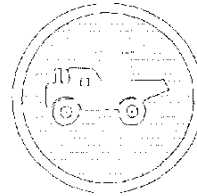

R126 : Vehicles conveying dangerous goods only sign:

COLOURS:

Border: White retro-reflective
Symbol: White & orange retro-reflective
Background: Blue retro-reflective

Temporary sign number TR126.
Indicates that the public road or a portion of the public road is set aside for use by vehicles conveying dangerous goods only, and that the driver of a vehicle conveying dangerous goods, shall only use that public road or portion of that public road.

R126

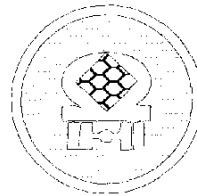

R127 : Abnormal vehicles only sign:

COLOURS:

Border & legend: White retro-reflective
Background: Blue retro-reflective

Temporary sign number TR127.
Indicates that the public road or a portion of the public road is set aside for use by abnormal vehicles only, and that the driver of an abnormal vehicle shall only use that public road or portion of that public road.

R127

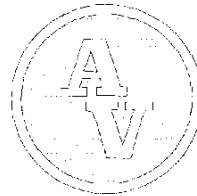

R128 : Rickshaws only sign:

COLOURS:

Border & symbol: White retro-reflective
Background: Blue retro-reflective

Temporary sign number TR128.
Indicates that the public road or a portion of the public road is set aside for use by rickshaws only, and that the person pulling a rickshaw shall only use that public road or portion of that public road.

R128

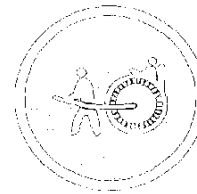

REGULATIONS
Road Traffic and Transport Act 22 of 1999
Road Traffic and Transport Regulations, 2001

R129 : Tour buses only sign:

COLOURS:

Border, legend & symbol: White retro-reflective
Background: Blue retro-reflective

Temporary sign number TR129.
Indicates that the public road or a portion of the public road is set aside for use by tour buses only and that the driver of a tour bus shall only use that public road or portion of that public road.

R129

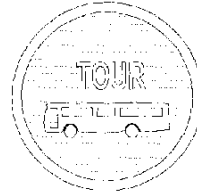

R130 : Agricultural vehicles only sign:

COLOURS:

Border & symbol: White retro-reflective
Background: Blue retro-reflective

Temporary sign number TR130.
Indicates that the public road or a portion of the public road is set aside for use by agricultural vehicles only and the driver of an agricultural vehicle shall only use that public road or portion of that public road.

R130

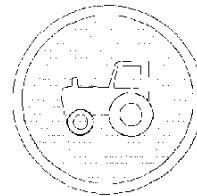

R131 : Animal-drawn vehicles only sign:

COLOURS:

Border & symbol: White retro-reflective
Background: Blue retro-reflective

Temporary sign number TR131.
Indicates that the public road or a portion of the public road is set aside for use by animal-drawn vehicles only and that the driver of an animal-drawn vehicle shall only use that public road or portion of that public road.

R131

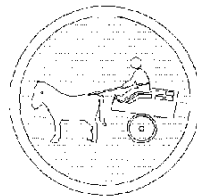

R132 : Pay toll sign:

COLOURS:

Border & legend: White retro-reflective
Background: Blue retro-reflective

Indicates to the driver of a vehicle that he or she may only proceed on a public road designated as a toll road if he or she is able to pay the toll charge and that he or she shall pay the toll charge at the toll plaza or plazas concerned.

R132

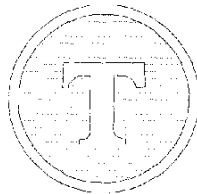

REGULATIONS
Road Traffic and Transport Act 22 of 1999
Road Traffic and Transport Regulations, 2001

R133 : Switch head lamps on sign:

COLOURS:

Border & symbol: White retro-reflective
Background: Blue retro-reflective

Temporary sign number TR133.
Indicates to the driver of a vehicle that he or she shall switch on such vehicle's head lamps to emit a dipped-beam.

R133

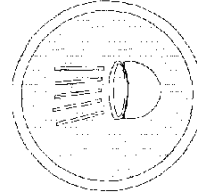

R134 : Buses and minibuses only sign:

COLOURS:

Border & symbol: White retro-reflective
Background: Blue retro-reflective

Temporary sign number TR134.
Indicates that the public road or portion of the public road is set aside for use by buses and minibuses only and that the driver of a bus or minibus shall use only that public road or portion of that public road.

R134

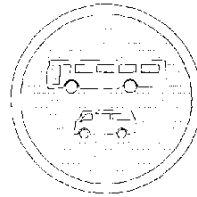

R135 and R136: No sign allocated:

R137 : Traffic circle:

COLOURS:

Border & symbol: White retro-reflective
Background: Blue retro-reflective

Temporary sign number TR137.
Indicates to the driver of a vehicle that he or she shall move in a clockwise direction at the intersection ahead and he or she shall yield right of way to traffic approaching from the right, within the traffic circle, where the traffic is so close as to constitute a danger or potential danger.

R137

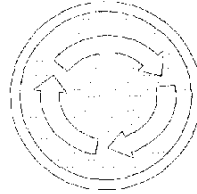

R138 : Trams only sign:

COLOURS:

Border & symbol: White retro-reflective
Background: Blue retro-reflective

Indicates that the public road or a portion of the public road is set aside for use by trams only and that the driver of a tram shall only use that public road or portion of that public road.

R138

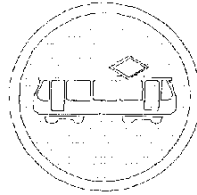

REGULATIONS
Road Traffic and Transport Act 22 of 1999
Road Traffic and Transport Regulations, 2001

R139 : Buses and trams only sign:

COLOURS:

Border & symbol: White retro-reflective
Background: Blue retro-reflective

Indicates that the public road or a portion of the public road is set aside for use by buses and trams only and that the driver of a bus or a tram shall only use that public road or portion of that public road.

R139

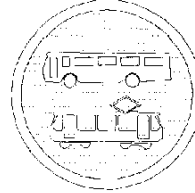

R140 : Buses, trams and minibuses only sign:

COLOURS:

Border & symbol: White retro-reflective
Background: Blue retro-reflective

Indicates that the public road or a portion of the public road is set aside for use by buses, trams and minibuses only and that the driver of a bus, tram or minibus shall only use that public road or portion of that public road.

R140

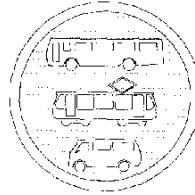

REGULATIONS
Road Traffic and Transport Act 22 of 1999
Road Traffic and Transport Regulations, 2001

C. Prohibition Signs:

R201 : Speed limit sign:

R201

COLOURS:

Border: Red retro-reflective
Legend: Black semi-matt
Background: White retro-reflective

Temporary sign number TR201.
Indicates to the driver of a vehicle that the speed limit beyond such sign is the speed indicated in kilometres per hour by the number on that sign and that he or she shall not exceed that speed limit.

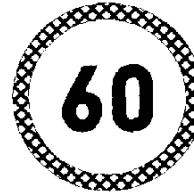

R202 : Mass limit sign:

R202

COLOURS:

Border: Red retro-reflective
Legend: Black semi-matt
Background: White retro-reflective

Temporary sign number TR202.
Indicates to the driver of a vehicle with a gross vehicle mass (GVM) or gross combination mass (GCM) exceeding the mass indicated in tonnes by the number on the sign, that he or she shall not proceed beyond such sign.

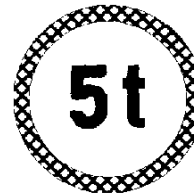

R203 : Axle massload limit sign:

R203

COLOURS:

Border: Red retro-reflective
Legend & symbol: Black semi-matt
Background: White retro-reflective

Temporary sign number TR203.
Indicates to the driver of a vehicle with a gross axle massload (GA) in excess of the axle mass indicated in tonnes by the number on the sign, that he or she shall not proceed beyond such sign.

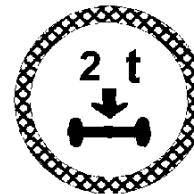

REGULATIONS
Road Traffic and Transport Act 22 of 1999
Road Traffic and Transport Regulations, 2001

R204 : Height limit sign:

COLOURS:

Border: Red retro-reflective
 Legend & symbol: Black semi-matt
 Background: White retro-reflective

Temporary sign number TR204.
 Indicates to the driver of a vehicle that he or she shall not proceed beyond the sign or drive under a height gauge or structure to which the sign is attached unless the overall height of the vehicle, and, in the case of a height gauge, any radio antenna attached to the vehicle, is less than the clearance height indicated in metres by means of a number on that sign.

R204

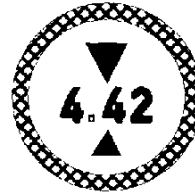

R205 : Length limit sign:

COLOURS:

Border: Red retro-reflective
 Legend & symbol: Black semi-matt
 Background: White retro-reflective

Temporary sign number TR205.
 (a) Indicates to the driver of a vehicle where the overall length of the vehicle is in excess of the length indicated in metres by the number on that sign, that he or she shall not proceed beyond such sign.
 (b) The value indicated in metres on the sign, is the maximum length of the vehicle, or combination of vehicles, including any projections.

R205

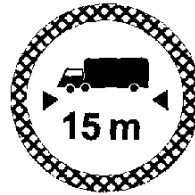

R206 : Excessive noise prohibited sign:

COLOURS:

Border & diagonal: Red retro-reflective
 Symbol: Black semi-matt
 Background: White retro-reflective

Temporary sign number TR206.
 Indicates to the driver of a vehicle that he or she shall not -
 (a) sound the vehicle's sounding device or hooter for 100 metres after passing such sign;
 (b) proceed beyond such sign, if that vehicle is emitting noise in excess of the noise levels prescribed by any noise control legislation.

R206



REGULATIONS
Road Traffic and Transport Act 22 of 1999
Road Traffic and Transport Regulations, 2001

R207 : Hitch-hiking prohibited sign:

R207

COLOURS:

Border & diagonal: Red retro-reflective
 Symbol: Black semi-matt
 Background: White retro-reflective



- (a) Indicates to -
 (i) a pedestrian that he or she shall not attempt to secure a lift from a passing vehicle; and
 (ii) the driver of a vehicle that he or she shall not pick up passengers.
 (b) This prohibition on hitch-hiking is effective for a distance of 500 metres beyond such sign.

R208 : Unauthorised vehicles prohibited sign:

R208

COLOURS:

Border: Red retro-reflective
 Symbol: Black semi-matt
 Background: White retro-reflective

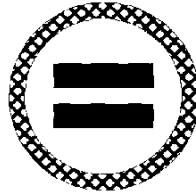

Temporary sign number TR208.
 Indicates to the driver of a vehicle that he or she shall not proceed beyond such sign unless he or she is authorised to do so.

R209 : Left turn ahead prohibited sign:

R209

COLOURS:

Border & diagonal: Red retro-reflective
 Arrow: Black semi-matt
 Background: White retro-reflective

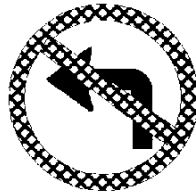

Temporary sign number TR209.
 Indicates to the driver of a vehicle that he or she shall not turn to the left at the junction or entrance ahead.

R210 : Right turn ahead prohibited sign:

R210

COLOURS:

Border & diagonal: Red retro-reflective
 Arrow: Black semi-matt
 Background: White retro reflective

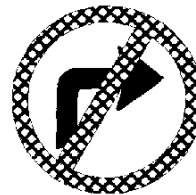

Temporary sign number TR210.
 Indicates to the driver of a vehicle that he or she shall not turn to the right at the junction or entrance ahead.

REGULATIONS
Road Traffic and Transport Act 22 of 1999
Road Traffic and Transport Regulations, 2001

R211 : Left turn prohibited sign:

R211

COLOURS:

Border & diagonal: Red retro-reflective
Arrow: Black semi-matt
Background: White retro-reflective

Temporary sign number TR211.
Indicates to the driver of a vehicle that he or she shall not turn to the left.

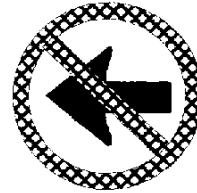

R212 : Right turn prohibited sign:

R212

COLOURS:

Border & diagonal: Red retro-reflective
Arrow: Black semi-matt
Background: White retro-reflective

Temporary sign number TR212.
Indicates to the driver of a vehicle that he or she shall not turn to the right.

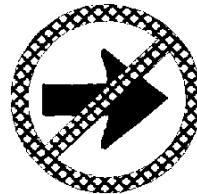

R213 : U-turn prohibited sign:

R213

COLOURS:

Border & diagonal: Red retro-reflective
Arrow: Black semi-matt
Background: White retro-reflective

Indicates to the driver of a vehicle that he or she shall not turn the vehicle so as to face in the opposite direction.

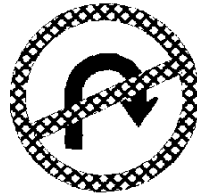

R214 : Overtaking prohibited sign:

R214

COLOURS:

Border & diagonal: Red retro-reflective
Symbol: Black semi-matt
Background: White retro-reflective

Temporary sign number TR214.
(a) Indicates to the driver of a vehicle that he or she shall not overtake another vehicle travelling in the same direction.
(b) The prohibition on overtaking is effective for a distance of 500 metres beyond such sign, or less if so indicated by a supplementary sign.

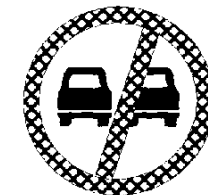

REGULATIONS
Road Traffic and Transport Act 22 of 1999
Road Traffic and Transport Regulations, 2001

R215 : Overtaking by goods vehicle prohibited sign:

R215

COLOURS:

Border & diagonal: Red retro-reflective
 Symbol: Black semi-matt
 Background: White retro-reflective

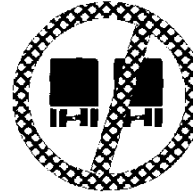

Temporary sign number TR215.

- (a) Indicates to the driver of a goods vehicle that he or she shall not overtake another goods vehicle travelling in the same direction.
- (b) The prohibition on overtaking is effective for a distance of 500 metres beyond such sign, or less if so indicated by a supplementary sign.

R216 : Parking prohibited sign:

R216

COLOURS:

Border & diagonal: Red retro-reflective
 Symbol: Black semi-matt
 Background: White retro-reflective

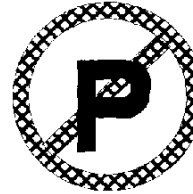

Temporary sign number TR216.

Indicates to the driver of a vehicle that he or she shall not park the vehicle at any time on any portion of a public road indicated by such sign.

R217 : Stopping prohibited sign:

R217

COLOURS:

Border & diagonal: Red retro-reflective
 Symbol: Black semi-matt
 Background: White retro-reflective

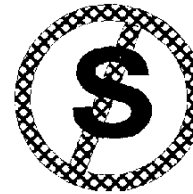

Temporary sign number TR217.

Indicates to the driver of a vehicle that he or she shall not stop the vehicle at any time on a roadway or shoulder of a public road where that sign is displayed and that regulation 319 applies.

R218 : Pedestrian prohibited sign:

R218

COLOURS:

Border & diagonal: Red retro-reflective
 Symbol: Black semi-matt
 Background: White retro-reflective



Temporary sign number TR218.

Indicates to a pedestrian that he or she shall not proceed beyond such sign.

REGULATIONS
Road Traffic and Transport Act 22 of 1999
Road Traffic and Transport Regulations, 2001

R219 : Pedal cycle prohibited sign:

COLOURS:

Border & diagonal: Red retro-reflective
Symbol: Black semi-matt
Background: White retro-reflective

Temporary sign number TR219.
Indicates to a pedal cyclist that he or she shall not proceed beyond such sign.

R219

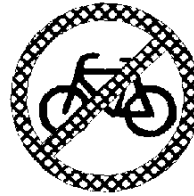

R220 : Pedal cycle and pedestrian prohibited sign:

COLOURS:

Border & diagonal: Red retro-reflective
Symbol: Black semi-matt
Background: White retro-reflective

Temporary sign number TR220.
Indicates to a pedal cyclist and a pedestrian that he or she shall not proceed beyond such sign.

R220



R221 : No sign allocated

R222 : Motor cycle prohibited sign:

COLOURS:

Border & diagonal: Red retro-reflective
Symbol: Black semi-matt
Background: White retro-reflective

Temporary sign number TR222.
Indicates to the driver of a motor cycle that he or she shall not proceed beyond such sign.

R222



R223 : Motor car prohibited sign:

COLOURS:

Border & diagonal: Red retro-reflective
Symbol: Black semi-matt
Background: White retro-reflective

Temporary sign number TR223.
Indicates to the driver of a motor car that he or she shall not proceed beyond such sign.

R223



REGULATIONS
Road Traffic and Transport Act 22 of 1999
Road Traffic and Transport Regulations, 2001

R224 : Taxi prohibited sign:

COLOURS:

Border & diagonal: Red retro-reflective
Symbol: Black semi-matt
Background: White retro-reflective

Temporary sign number TR224.
Indicates to the driver of a taxi that he or she shall not proceed beyond such sign.

R224



R225 : Minibus prohibited sign:

COLOURS:

Border & diagonal: Red retro-reflective
Symbol: Black semi-matt
Background: White retro-reflective

Temporary sign number TR225.
Indicates to the driver of a minibus that he or she shall not proceed beyond such sign.

R225



R226 : Midibus prohibited sign:

COLOURS:

Border & diagonal: Red retro-reflective
Symbol: Black semi-matt
Background: White retro-reflective

Temporary sign number TR226.
Indicates to the driver of a midibus that he or she shall not proceed beyond such sign.

R226



R227 : Bus prohibited sign:

COLOURS:

Border & diagonal: Red retro-reflective
Symbol: Black semi-matt
Background: White retro-reflective

Temporary sign number TR227.
Indicates to the driver of a bus that he or she shall not proceed beyond such sign.

R227

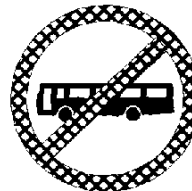

REGULATIONS
Road Traffic and Transport Act 22 of 1999
Road Traffic and Transport Regulations, 2001

R228 : Delivery vehicle prohibited sign:

COLOURS:

Border & diagonal: Red retro-reflective
 Symbol: Black semi-matt
 Background: White retro-reflective

Temporary sign number TR228.

Indicates to the driver of a delivery vehicle that he or she shall not proceed beyond such sign.

R228



R229 : Goods vehicle prohibited sign:

COLOURS:

Border & diagonal: Red retro-reflective
 Symbol: Black semi-matt
 Background: White retro-reflective

Temporary sign number TR229.

Indicates to the driver of a goods vehicle that he or she shall not proceed beyond such sign.

R229



R230 : Goods vehicle over indicated GVM prohibited sign:

COLOURS:

Border & diagonal: Red retro-reflective
 Symbol: Black semi-matt
 Legend: White retro-reflective
 Background: White retro-reflective

Temporary sign number TR230.

Indicates to the driver of a goods vehicle with a gross vehicle mass (GVM) or a gross combination mass (GCM) in excess of that mass indicated in tonnes by the number on the sign, that he or she shall not proceed beyond such sign.

R230



R231 : Construction vehicle prohibited sign:

COLOURS:

Border & diagonal: Red retro-reflective
 Symbol: Black semi-matt
 Background: White retro-reflective

Temporary sign number TR231.

Indicates to the driver of a construction vehicle that he or she shall not proceed beyond such sign.

R231



REGULATIONS
Road Traffic and Transport Act 22 of 1999
Road Traffic and Transport Regulations, 2001

R232 : Vehicle conveying dangerous goods prohibited sign:

R232

COLOURS:

Border & diagonal: Red retro-reflective
 Symbol: Black semi-matt & orange retro-reflective
 Background: White retro-reflective

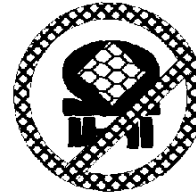

Temporary sign number TR232.
 Indicates to the driver of a vehicle conveying dangerous goods that he or she shall not proceed beyond such sign.

R233 : Abnormal vehicle prohibited sign:

R233

COLOURS:

Border & diagonal: Red retro-reflective
 Legend: Black semi-matt
 Background: White retro-reflective

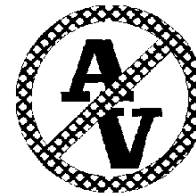

Temporary sign number TR233.
 Indicates to the driver of an abnormal vehicle that he or she shall not proceed beyond such sign.

R234 : Rickshaw prohibited sign:

R234

COLOURS:

Border & diagonal: Red retro-reflective
 Symbol: Black semi-matt
 Background: White retro-reflective



Temporary sign number TR234.
 Indicates to the person pulling a rickshaw that he or she shall not proceed beyond such sign.

R235 : Tour bus prohibited sign:

R235

COLOURS:

Border & diagonal: Red retro-reflective
 Symbol & legend: Black semi-matt
 Background: White retro-reflective

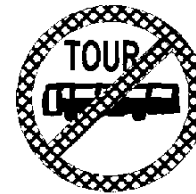

Temporary sign number TR235.
 Indicates to the driver of a tour bus that he or she shall not proceed beyond such sign.

REGULATIONS
Road Traffic and Transport Act 22 of 1999
Road Traffic and Transport Regulations, 2001

R236 : Agricultural vehicle prohibited sign:

R236

COLOURS:

Border & diagonal: Red retro-reflective
 Symbol: Black semi-matt
 Background: White retro-reflective

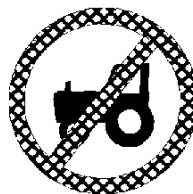

Temporary sign number TR236.
 Indicates to the driver of an agricultural vehicle that he or she shall not proceed beyond such sign.

R237 : Animal-drawn vehicle prohibited sign:

R237

COLOURS:

Border & diagonal: Red retro-reflective
 Symbol: Black semi-matt
 Background: White retro-reflective

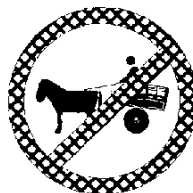

Temporary sign number TR237.
 Indicates to the driver of an animal-drawn vehicle that he or she shall not proceed beyond such sign.

R238 : Horses and riders prohibited sign:

R238

COLOURS:

Border & diagonal: Red retro-reflective
 Symbol: Black semi-matt
 Background: White retro-reflective



Temporary sign number TR238.
 Indicates to a horse rider that horses and riders, whether mounted on or leading a horse shall not proceed beyond that sign.

R239 : Width limit sign:

R239

COLOURS:

Border & diagonal: Red retro-reflective
 Symbol: Black semi-matt
 Background: White retro-reflective

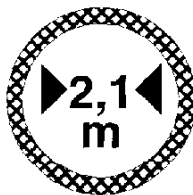

- Temporary sign number TR239.
- (a) Indicates to the driver of a vehicle that he or she shall not proceed beyond the sign unless the overall width of the vehicle, is less than the width indicated in metres by the number on such sign.
 - (b) The value indicated in metres on the sign, is the maximum width of the vehicle, or combination of vehicles, including any projections.

REGULATIONS
Road Traffic and Transport Act 22 of 1999
Road Traffic and Transport Regulations, 2001

R240 : Towed vehicles prohibited sign:

COLOURS:

Border & diagonal: Red retro-reflective
Symbol: Black semi-matt
Background: White retro-reflective

Temporary sign number TR240.
Indicates to the driver of a vehicle that no vehicle which is towing another vehicle shall proceed beyond such sign.

R240

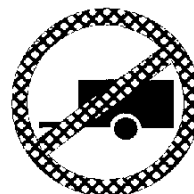

R241 : Hawkers prohibited sign:

COLOURS:

Border & diagonal: Red retro-reflective
Symbol: Black semi-matt
Background: White retro-reflective

Temporary sign number TR241.
Indicates that no hawkers are allowed within 75 metres on either side of such sign.

R241



REGULATIONS
Road Traffic and Transport Act 22 of 1999
Road Traffic and Transport Regulations, 2001

D. Reservation Signs:

R301 : Bus reservation sign:

R301

COLOURS:

Border, symbol, & legend: White retro-reflective or semi-matt
 Background: Blue retro-reflective or semi-matt

Temporary sign number TR301.
 Indicates to the driver of a vehicle that the public road or a portion of the public road is reserved for buses only.

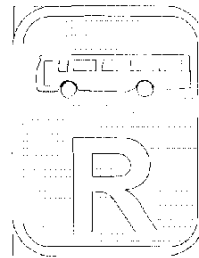

R302 : Bus lane reservation sign:

R302

COLOURS:

Border, symbol & legend: White & yellow retro-reflective or semi-matt
 Background: Blue retro-reflective or semi-matt

Temporary sign number TR302.
 Indicates to the driver of a vehicle that the portion of the public road is a bus lane and is reserved for buses only.

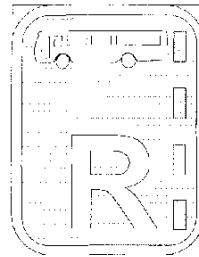

R303 : Bus lane reservation begins sign:

R303

COLOURS:

Border, symbol, & legend: White & yellow retro-reflective or semi-matt
 Background: Blue retro-reflective or semi-matt

Temporary sign number TR303.
 Indicates to the driver of a vehicle that a bus lane is beginning and that such lane is reserved for buses only.

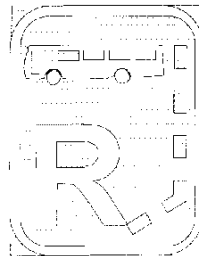

R304 : Bicycle lane reservation sign:

R304

COLOURS:

Border, symbol, & legend: White & yellow retro-reflective or semi-matt
 Background: Blue retro-reflective or semi-matt

Temporary sign number TR304.
 Indicates to the driver of a vehicle that the portion of the public road is a bicycle lane and is reserved for bicycles only.

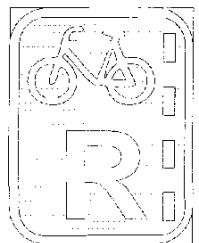

REGULATIONS
Road Traffic and Transport Act 22 of 1999
Road Traffic and Transport Regulations, 2001

R305 : No sign allocated

R306 : No sign allocated

R307 : Motor cycle reservation sign:

COLOURS:

Border, symbol & legend: White retro-reflective or semi-matt

Background: Blue retro-reflective or semi-matt

Temporary sign number TR307.

Indicates to the driver of a vehicle that the public road or a portion of the public road is reserved for motor cycles only.

R307

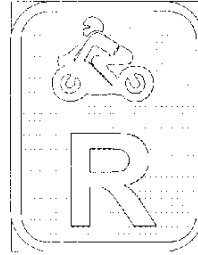

R308 : Motor car reservation sign:

COLOURS:

Border, symbol & legend: White retro-reflective or semi-matt

Background: Blue retro-reflective or semi-matt

Temporary sign number TR308.

Indicates to the driver of a vehicle that the public road or a portion of the public road is reserved for motor cars only.

R308

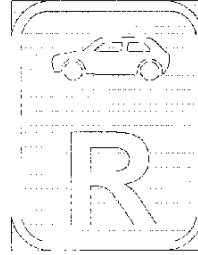

R309 : Taxi reservation sign:

COLOURS:

Border, symbol & legend: White retro-reflective or semi-matt

Background: Blue retro-reflective or semi-matt

Temporary sign number TR309.

Indicates to the driver of a vehicle that the public road or a portion of the public road is reserved for taxis only.

R309

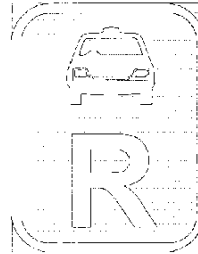

R310 : Minibus reservation sign:

COLOURS:

Border, symbol & legend: White retro-reflective or semi-matt

Background: Blue retro-reflective or semi-matt

Temporary sign number TR310.

Indicates to the driver of a vehicle that the public road or a portion of the public road is reserved for minibuses only.

R310

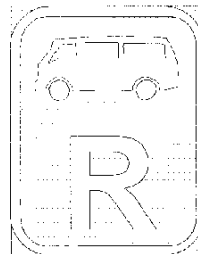

REGULATIONS
Road Traffic and Transport Act 22 of 1999
Road Traffic and Transport Regulations, 2001

R311 : Midibus reservation sign:

COLOURS:

Border, symbol & legend: White retro-reflective or semi-matt
 Background: Blue retro-reflective or semi-matt

Temporary sign number TR311.

Indicates to the driver of a vehicle that the public road or portion of the public road is reserved for midibuses only.

R311

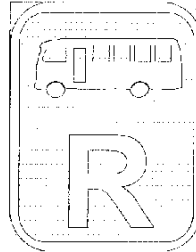

R312 : Delivery vehicle reservation sign:

COLOURS:

Border, symbol & legend: White retro-reflective or semi-matt
 Background: Blue retro-reflective or semi-matt

Temporary sign number TR312.

Indicates to the driver of a vehicle that the public road or a portion of the public road is reserved for delivery vehicles only.

R312

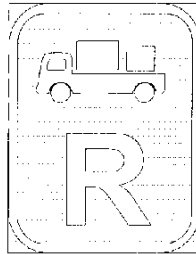

R313 : Goods vehicle reservation sign:

COLOURS:

Border, symbol & legend: White retro-reflective or semi-matt
 Background: Blue retro-reflective or semi-matt

Temporary sign number TR313.

Indicates to the driver of a vehicle that the public road or a portion of the public road is reserved for goods vehicles only.

R313

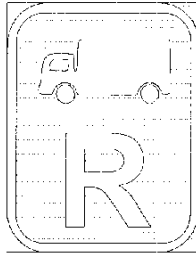

R314 : Goods vehicle over indicated GVM reservation sign:

COLOURS:

Border, symbol & legend: White retro-reflective or semi-matt
 Legend on symbol: Black semi-matt
 Background: Blue retro-reflective or semi-matt

Temporary sign number TR314.

Indicates to the driver of a vehicle that the public road or a portion of the public road is reserved for goods vehicles with a gross vehicle mass (GVM) or gross combination mass (GCM) exceeding the

R314

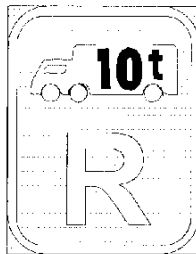

REGULATIONS
Road Traffic and Transport Act 22 of 1999
Road Traffic and Transport Regulations, 2001

mass indicated in tonnes by the number on the sign, only.

R315 : Construction vehicle reservation sign:

R315

COLOURS:

Border, symbol & legend: White retro-reflective or semi-matt
 Background: Blue retro-reflective or semi-matt

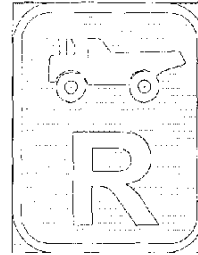

Temporary sign number TR315.
 Indicates to the driver of a vehicle that the public road or a portion of the public road is reserved for construction vehicles only.

R316 : Vehicle conveying dangerous goods reservation sign:

R316

COLOURS:

Border & legend: White retro-reflective or semi-matt
 Symbol: White & orange retro-reflective
 Background: Blue retro-reflective or semi-matt

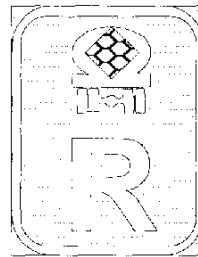

Temporary sign number TR316.
 Indicates to the driver of a vehicle that the public road or a portion of the public road is reserved for vehicles conveying dangerous goods only.

R317 : Abnormal vehicle reservation sign:

R317

COLOURS:

Border & legend: White retro-reflective or semi-matt
 Background: Blue retro-reflective or semi-matt

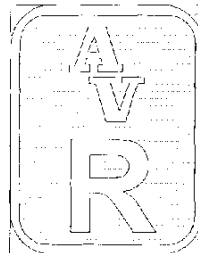

Temporary sign number TR317.
 Indicates to the driver of a vehicle that the public road or a portion of the public road is reserved for abnormal vehicles only.

REGULATIONS
Road Traffic and Transport Act 22 of 1999
Road Traffic and Transport Regulations, 2001

R318 : Rickshaw reservation sign:

COLOURS:

Border, symbol & legend: White retro-reflective or semi-matt
 Background: Blue retro-reflective or semi-matt

Temporary sign number TR318.
 Indicates to the driver of a vehicle that the public road or a portion of the public road is reserved for rickshaws only.

R318

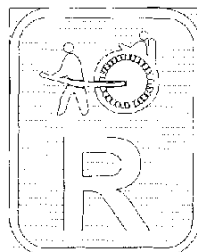

R319 : Tour bus reservation sign:

COLOURS:

Border, symbol & legend: White retro-reflective or semi-matt
 Background: Blue retro-reflective or semi-matt

Temporary sign number TR319.
 Indicates to the driver of a vehicle that a public road or a portion of the public road is reserved for tour buses only.

R319

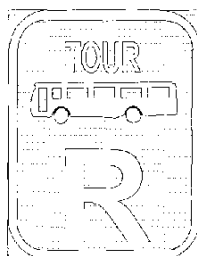

R320 : High occupancy vehicle reservation sign:

COLOURS:

Border, symbol & legend: White retro-reflective or semi-matt
 Legend on symbol: Black semi-matt
 Background: Blue retro-reflective or semi-matt

Temporary sign number TR320.
 Indicates to the driver of a vehicle that the public road or a portion of the public road is reserved for high occupancy vehicles only.

R320

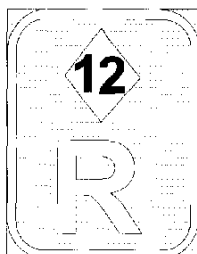

R321 : Emergency services vehicle reservation sign:

COLOURS:

Border & legend: White retro-reflective or semi-matt
 Symbols: White & red retro-reflective
 Background: Blue retro-reflective or semi-matt

Temporary sign number TR321.
 Indicates to the driver of a vehicle that the public road or a portion of the public road is reserved for

R321

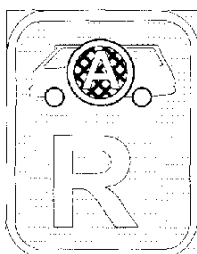

REGULATIONS
Road Traffic and Transport Act 22 of 1999
Road Traffic and Transport Regulations, 2001

emergency services vehicles only.

R322(Nam) : Police vehicle reservation sign:

R322(Nam)

COLOURS:

Border & legend: White retro-reflective or semi-matt
 Symbol: White, yellow, black & red retro-reflective or semi-matt
 Background: Blue retro-reflective or semi-matt

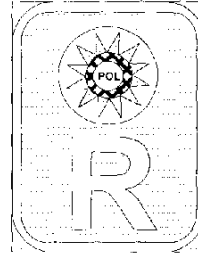

Temporary sign number TR322 (Nam).
 Indicates to the driver of a vehicle that the public road or portion of the public road is reserved for police vehicles only.

R323 : Vehicle with disabled person reservation sign:

R323

COLOURS:

Border, symbol & legend: White retro-reflective or semi-matt
 Background: Blue retro-reflective or semi-matt

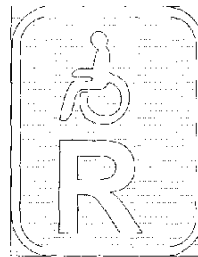

Temporary sign number TR323.
 Indicates to the driver of a vehicle that the public road or a portion of the public road is reserved for vehicles carrying disabled persons only.

R324 : Authorised vehicle reservation sign:

R324

COLOURS:

Border, symbol & legend: White retro-reflective or semi-matt
 Legend on symbol: Black semi-matt or appropriate colour, retro-reflective or semi-matt
 Background: Blue retro-reflective or semi-matt

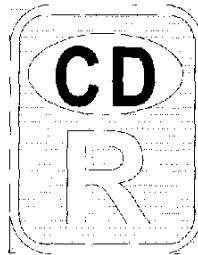

Temporary sign number TR324.
 Indicates to the driver of a vehicle that the public road or a portion of the public road is reserved for the authorised vehicles indicated on the sign only.

REGULATIONS
Road Traffic and Transport Act 22 of 1999
Road Traffic and Transport Regulations, 2001

R325 : Bus stop reservation sign:

COLOURS:

Border & symbol: White retro-reflective or semi-matt
 Logo: Colour of specific logo
 Zone: Colour coded
 Legend on zone: Black semi-matt
 Background: Blue retro-reflective or semi-matt

Temporary sign number TR325.
 Indicates to the driver of a vehicle that a portion of the public road is reserved as a bus stop for the buses of the organisation indicated by means of a crest, logo or other device on such sign.

R325

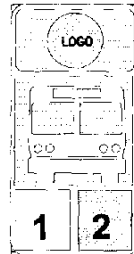

R326 : Minibus stop reservation sign:

COLOURS:

Border & symbol: White retro-reflective or semi-matt
 Logo: Colour of specific logo
 Zone: Colour coded
 Legend on zone: Black semi-matt
 Background: Blue retro-reflective or semi-matt

Temporary sign number TR326.
 Indicates to the driver of a vehicle that a portion of the public road is reserved as a minibus stop for the minibuses of the organisation indicated by means of a crest, logo or other device on such sign.

R326



R327 : Bus and minibus reservation sign:

COLOURS:

Border, symbol & legend: White retro-reflective or semi-matt
 Background: Blue retro-reflective or semi-matt

Temporary sign number TR327.
 Indicates to the driver of a vehicle that the public road or a portion of the public road is reserved for buses and minibuses only.

R327

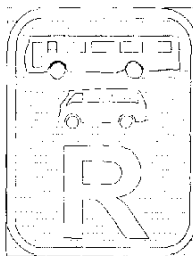

REGULATIONS
Road Traffic and Transport Act 22 of 1999
Road Traffic and Transport Regulations, 2001

R328 : Bus and minibus lane reservation sign:

R328

COLOURS:

Border, symbol & legend: White and yellow retro-reflective or semi-matt
 Background: Blue retro-reflective or semi-matt

Temporary sign number TR328.
 Indicates to the driver of a vehicle that a portion of a public road is a bus and minibus lane and is reserved for buses and minibuses only.

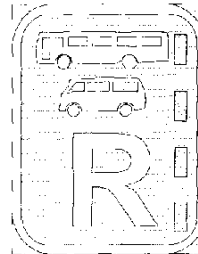

R329 : Bus and minibus lane reservation begins sign:

R329

COLOURS:

Border, symbol & legend: White and yellow retro-reflective or semi-matt
 Background: Blue retro-reflective or semi-matt

Temporary sign number TR329.
 Indicates to the driver of a vehicle that a bus and minibus lane is beginning and that such lane is reserved for buses and minibuses only.

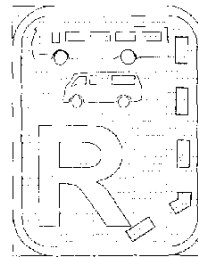

R330 : Bus and midibus reservation sign:

R330

COLOURS:

Border, symbol & legend: White retro-reflective or semi-matt
 Background: Blue retro-reflective or semi-matt

Temporary sign number TR330.
 Indicates to the driver of a vehicle that the public road or a portion of the public road is reserved for buses and midibuses only.

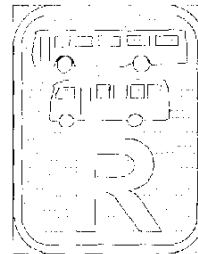

R331 : Bus and midibus lane reservation sign:

R331

COLOURS:

Border, symbol & legend: White and yellow retro-reflective or semi-matt
 Background: Blue retro-reflective or semi-matt

Temporary sign number TR331.
 Indicates to the driver of a vehicle that a portion of a public road is a bus and midibus lane and is reserved for buses and midibuses only.

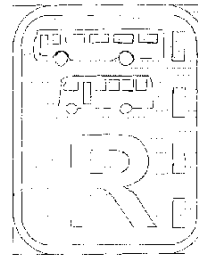

REGULATIONS
Road Traffic and Transport Act 22 of 1999
Road Traffic and Transport Regulations, 2001

R332 : Bus and midibus lane reservation begins sign:

COLOURS:

Border, symbol & legend: White and yellow retro-reflective or semi-matt
 Background: Blue retro-reflective or semi-matt

Temporary sign number TR332.
 Indicates to the driver of a vehicle that a bus and midibus lane is beginning and that such lane is reserved for buses and midibuses only.

R332

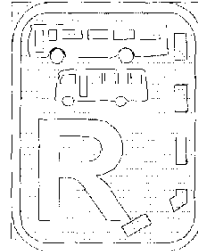

R333 : Bus, midibus and minibus reservation sign:

COLOURS:

Border, symbol & legend: White retro-reflective or semi-matt
 Background: Blue retro-reflective or semi-matt

Temporary sign number TR333.
 Indicates to the driver of a vehicle that the public road or a portion of the public road is reserved for buses, midibuses and minibuses only.

R333

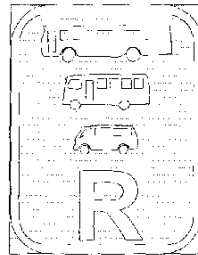

R334 : Bus, midibus and minibus lane reservation sign:

COLOURS:

Border, symbol & legend: White and yellow retro-reflective or semi-matt
 Background: Blue retro-reflective or semi-matt

Temporary sign number TR334.
 Indicates to the driver of a vehicle that a portion of a public road is a bus, midibus and minibus lane and is reserved for buses, midibuses and minibuses only.

R334

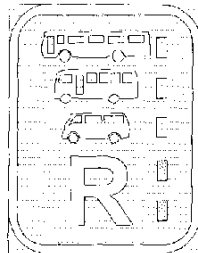

REGULATIONS
Road Traffic and Transport Act 22 of 1999
Road Traffic and Transport Regulations, 2001

R335 : Bus, midibus and minibus lane reservation begins sign:

COLOURS:

Border, symbol & legend:	White and yellow retro-reflective or semi-matt
Background:	Blue retro-reflective or semi-matt

Temporary sign number TR335.
 Indicates to the driver of a vehicle that a bus, midibus and minibus lane is beginning and that such lane is reserved for buses, midibuses and minibuses only.

R335

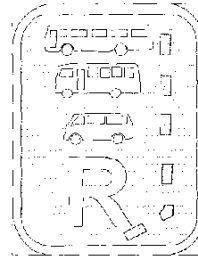

R336 : High occupancy vehicle lane reservation sign:

COLOURS:

Border, symbol & legend:	White and yellow retro-reflective or semi-matt
Legend on symbol:	Black semi-matt
Background:	Blue retro-reflective or semi-matt

Temporary sign number TR336.
 Indicates to the driver of a vehicle that the portion of the public road is a high occupancy vehicle lane and is reserved for high occupancy vehicles only.

R336

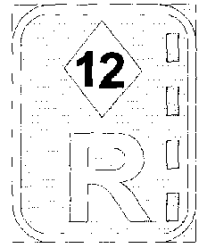

R337 : High occupancy vehicle lane reservation begins sign:

COLOURS:

Border, symbol & legend:	White and yellow retro-reflective or semi-matt
Legend on symbol:	Black semi-matt
Background:	Blue retro-reflective or semi-matt

Temporary sign number TR337.
 Indicates to the driver of a vehicle that a high occupancy vehicle lane is beginning and that the lane is reserved for high occupancy vehicles only.

R337

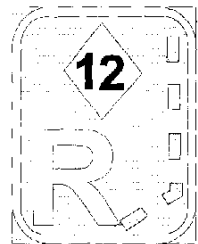

REGULATIONS
Road Traffic and Transport Act 22 of 1999
Road Traffic and Transport Regulations, 2001

R338 : Tram reservation sign:

COLOURS:

Border, symbol & legend: White retro-reflective or semi-matt
 Background: Blue retro-reflective or semi-matt

Temporary sign number TR338.
 Indicates to the driver of a vehicle that the public road or a portion of the public road is reserved for trams only.

R338

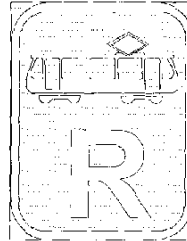

R339 : Tram lane reservation sign:

COLOURS

Border, symbol & legend: White and yellow retro-reflective or semi-matt
 Background: Blue retro-reflective or semi-matt

Temporary sign number TR339.
 Indicates to the driver of a vehicle that the portion of the public road is a tram lane and is reserved for trams only.

R339

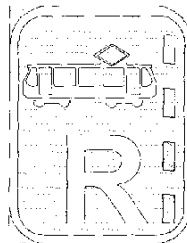

R340 : Tram lane reservation begins sign:

COLOURS:

Border, symbol & legend: White and yellow retro-reflective or semi-matt
 Background: Blue retro-reflective or semi-matt

Temporary sign number TR340.
 Indicates to the driver of a vehicle that a tram lane is beginning and that the lane is reserved for trams only.

R340

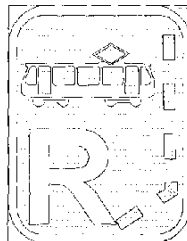

R341 : Tram stop reservation sign:

COLOURS:

Border, symbol & legend: White and yellow retro-reflective or semi-matt
 Legend on symbol: Black semi-matt
 Background: Blue retro-reflective or semi-matt

Temporary sign number TR341.
 Indicates to the driver of a vehicle that a portion of the public road is reserved as a tram stop for the trams of the organisation indicated by means of a crest, logo or other device on such sign.

R341



REGULATIONS
Road Traffic and Transport Act 22 of 1999
Road Traffic and Transport Regulations, 2001

R342 : Bus and tram reservation sign:

COLOURS:

Border, symbol & legend: White retro-reflective or semi-matt
 Background: Blue retro-reflective or semi-matt

Temporary sign number TR342.
 Indicates to the driver of a vehicle that the public road or a portion of the public road is reserved for buses and trams only.

R342

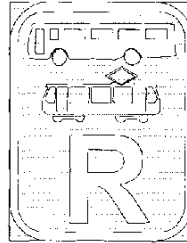

R343 : Bus and tram lane reservation sign:

COLOURS:

Border, symbol & legend: White and yellow retro-reflective or semi-matt
 Background: Blue retro-reflective or semi-matt

Temporary sign number TR343.
 Indicates to the driver of a vehicle that a portion of the public road is a bus and tram lane and is reserved for buses and trams only.

R343

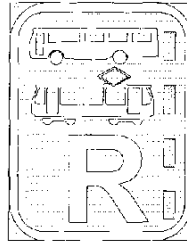

R344 : Bus and tram lane reservation begins sign:

COLOURS:

Border, symbol & legend: White and yellow retro-reflective or semi-matt
 Background: Blue retro-reflective or semi-matt

Temporary sign number TR344.
 Indicates to the driver of a vehicle that a bus and tram lane is beginning and that the lane is reserved for buses and trams only.

R344

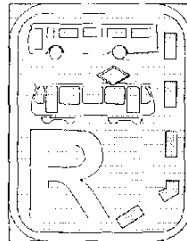

R345 : Bus, minibus and tram reservation sign:

COLOURS:

Border, symbol & legend: White retro-reflective or semi-matt
 Background: Blue retro-reflective or semi-matt

Temporary sign number TR345.
 Indicates to the driver of a vehicle that the public road or a portion of the public road is reserved for buses, minibuses and trams only.

R345

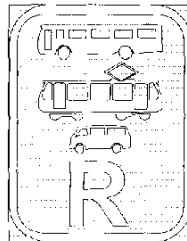

REGULATIONS
Road Traffic and Transport Act 22 of 1999
Road Traffic and Transport Regulations, 2001

R346 : Bus, minibus and tram lane reservation sign:

COLOURS:

Border, symbol & legend:	White and yellow retro-reflective or semi-matt
Background:	Blue retro-reflective or semi-matt

Temporary sign number TR346.
 Indicates to the driver of a vehicle that the portion of the public road is a bus, minibus and tram lane and that such lane is reserved for buses, minibuses and trams only.

R346

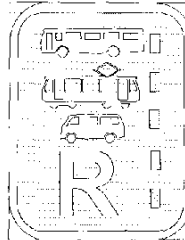

R347 : Bus, minibus and tram lane reservation begins sign:

COLOURS:

Border, symbol & legend:	White and yellow retro-reflective or semi-matt
Background:	Blue retro-reflective or semi-matt

Temporary sign number TR347.
 Indicates to the driver of a vehicle that a bus, minibus and tram lane is beginning and that such lane is reserved for buses, minibuses and trams only.

R347

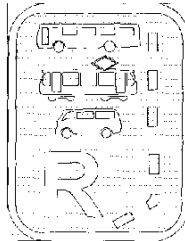

R348 : Bus lane right reservation sign:

COLOURS:

Border, symbol & legend:	White and yellow retro-reflective or semi-matt
Background:	Blue retro-reflective or semi-matt

Temporary sign number TR348.
 Indicates to the driver of a vehicle that the portion of the public road on the right hand side of the road is reserved for buses only.

R348

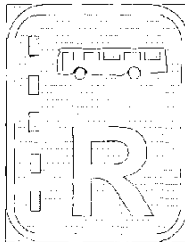

REGULATIONS
Road Traffic and Transport Act 22 of 1999
Road Traffic and Transport Regulations, 2001

R349 : Bus and minibus lane right reservation sign:

R349

COLOURS:

Border, symbol & legend: White and yellow retro-reflective or semi-matt
 Background: Blue retro-reflective or semi-matt

Temporary sign number TR349.
 Indicates to the driver of a vehicle that the portion of the public road on the right hand side of the road is reserved for buses and minibuses only.

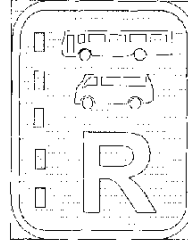

R350 : Bus and tram lane right reservation sign:

R350

COLOURS:

Border, symbol & legend: White and yellow retro-reflective or semi-matt
 Background: Blue retro-reflective or semi-matt

Temporary sign number TR350.
 Indicates to the driver of a vehicle that the portion of the public road on the right hand side of the road is reserved for buses and trams only.

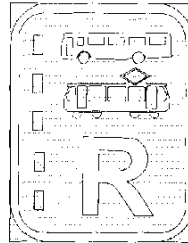

R351 : Bus, minibus and tram lane right reservation sign:

R351

COLOURS:

Border, symbol & legend: White and yellow retro-reflective or semi-matt
 Background: Blue retro-reflective or semi-matt

Temporary sign number TR351.
 Indicates to the driver of a vehicle that the portion of the public road on the right hand side of the road is reserved for buses, minibuses and trams only.

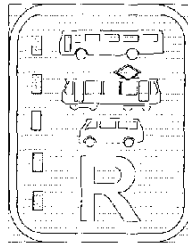

R352 : High occupancy vehicle lane right reservation sign:

R352

COLOURS:

Border, symbol & legend: White and yellow retro-reflective or semi-matt
 Legend on symbol: Black semi-matt
 Background: Blue retro-reflective or semi-matt

Temporary sign number TR352.
 Indicates to the driver of a vehicle that the portion of the public road on the right hand side of the road

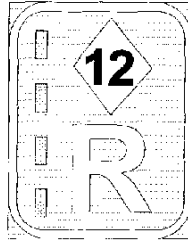

REGULATIONS
Road Traffic and Transport Act 22 of 1999
Road Traffic and Transport Regulations, 2001

is reserved for high occupancy vehicles only.

R353 : Authorised passenger transport vehicle lane - left reservation sign:

COLOURS:

Border, symbol & legend: White and yellow retro-reflective or semi-matt
 Background: Blue retro-reflective or semi-matt

Temporary sign number TR353.
 Indicates to the driver of a vehicle that the portion of the public road is reserved for authorised passenger transport vehicles only.

R353

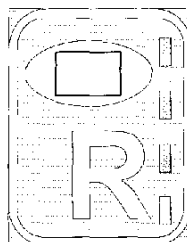

R354 : Authorised passenger transport vehicle lane - right reservation sign:

COLOURS:

Border, symbol & legend: White and yellow retro-reflective or semi-matt
 Background: Blue retro-reflective or semi-matt

Temporary sign number TR354.
 Indicates to the driver of a vehicle that the portion of the public road is reserved for authorised passenger transport vehicles only.

R354

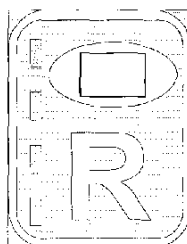

301P : Bus parking reservation sign:

COLOURS:

Border, symbol & legend: White retro-reflective or semi-matt
 Background: Blue retro-reflective or semi-matt

Temporary sign number TR301P.
 Indicates to the driver of a vehicle that a parking area is reserved for buses only.

R301P

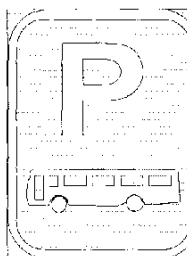

R302P and R303P: No sign allocated

REGULATIONS
Road Traffic and Transport Act 22 of 1999
Road Traffic and Transport Regulations, 2001

R304P : Pedal cycle parking reservation sign:

COLOURS:

Border, symbol & legend: White retro-reflective or semi-matt
 Background: Blue retro-reflective or semi-matt

Temporary sign number TR304P.
 Indicates to the driver of a vehicle that a parking area is reserved for pedal cycles only.

R304P

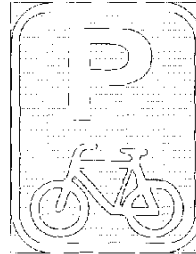

R305P : Parking reservation sign:

COLOURS:

Border & legend: White retro-reflective or semi-matt
 Background: Blue retro-reflective or semi-matt

Temporary sign number TR305P.
 Indicates to the driver of a vehicle that an area is reserved for parking.

R305P

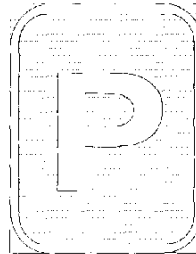

R306P : Limited parking reservation sign:

COLOURS:

Border & legend: White retro-reflective or semi-matt
 Background: Blue retro-reflective or semi-matt

Temporary sign number TR306P.
 Indicates to the driver of a vehicle that an area is reserved for parking for a maximum period as indicated on the sign.

R306P

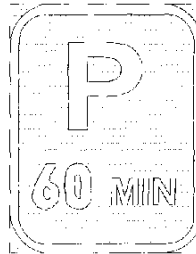

R307P : Motor cycle parking reservation sign:

COLOURS:

Border, symbol & legend: White retro-reflective or semi-matt
 Background: Blue retro-reflective or semi-matt

Temporary sign number TR307P.
 Indicates to the driver of a vehicle that a parking area is reserved for motor cycles only.

R307P

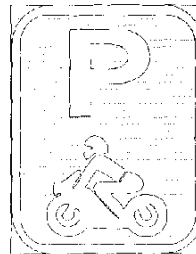

REGULATIONS
Road Traffic and Transport Act 22 of 1999
Road Traffic and Transport Regulations, 2001

R308P : Motor car parking reservation sign:

COLOURS:

Border, symbol & legend:	White retro-reflective or semi-matt
Background:	Blue retro-reflective or semi-matt

Temporary sign number TR308P.
 Indicates to the driver of a vehicle that a parking area is reserved for motor cars only.

R308P

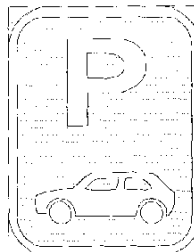

R309P : Taxi parking reservation sign:

COLOURS:

Border, symbol & legend:	White retro-reflective or semi-matt
Background:	Blue retro-reflective or semi-matt

Temporary sign number TR309P.
 Indicates to the driver of a vehicle that a parking area is reserved for taxis only.

R309P

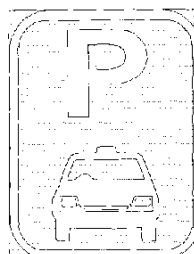

R310P : Minibus parking reservation sign:

COLOURS:

Border, symbol & legend:	White retro-reflective or semi-matt
Background:	Blue retro-reflective or semi-matt

Temporary sign number TR310P.
 Indicates to the driver of a vehicle that a parking area is reserved for minibuses.

R310P

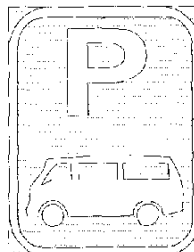

R311P : Midibus parking reservation sign:

COLOURS:

Border, symbol & legend:	White retro-reflective or semi-matt
Background:	Blue retro-reflective or semi-matt

Temporary sign number TR311P.
 Indicates to the driver of a vehicle that a parking area is reserved for midibuses only.

R311P

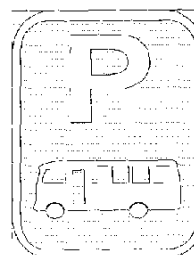

REGULATIONS
Road Traffic and Transport Act 22 of 1999
Road Traffic and Transport Regulations, 2001

R312P : Delivery vehicle parking reservation sign:

COLOURS:

Border, symbol & legend: White retro-reflective or semi-matt
 Background: Blue retro-reflective or semi-matt

Temporary sign number TR312P.
 Indicates to the driver of a vehicle that a parking area is reserved for delivery vehicles only.

R312P

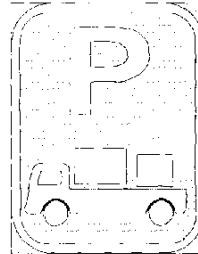

R313P : Goods vehicle parking reservation sign:

COLOURS:

Border, symbol & legend: White retro-reflective or semi-matt
 Background: Blue retro-reflective or semi-matt

Temporary sign number TR313P.
 Indicates to the driver of a vehicle that a parking area is reserved for goods vehicles only.

R313P

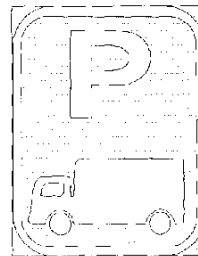

R314P : Goods vehicle over a certain GVM parking reservation sign:

COLOURS:

Border, symbol & legend: White retro-reflective or semi-matt
 Legend on symbol: Black semi-matt
 Background: Blue retro-reflective or semi-matt

Temporary sign number TR314P.
 Indicates to the driver of a vehicle that a parking area is reserved for goods vehicles with a gross vehicle mass (GVM) or gross combination mass (GCM) exceeding the mass indicated in tonnes on such sign, only.

R314P

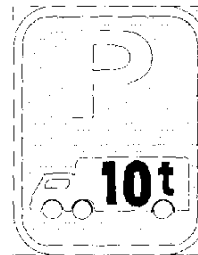

REGULATIONS
Road Traffic and Transport Act 22 of 1999
Road Traffic and Transport Regulations, 2001

R315P : Construction vehicle parking reservation sign:

COLOURS:

Border, symbol & legend: White retro-reflective or semi-matt
Background: Blue retro-reflective or semi-matt

Temporary sign number TR315P.
Indicates to the driver of a vehicle that a parking area is reserved for construction vehicles only.

R315P

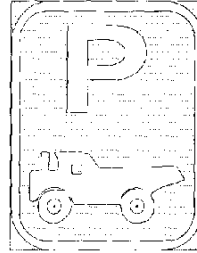

R316P : Vehicle conveying dangerous goods parking reservation sign:

COLOURS:

Border & legend: White retro-reflective or semi-matt
Symbols: White & orange retro-reflective or semi-matt
Background: Blue retro-reflective or semi-matt

Temporary sign number TR316P.
Indicates to the driver of a vehicle that a parking area is reserved for vehicles conveying dangerous goods only.

R316P

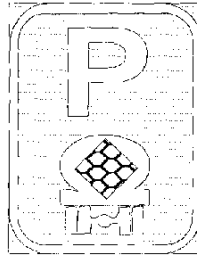

R317P : Abnormal vehicle parking reservation sign:

COLOURS:

Border & legend: White retro-reflective or semi-matt
Background: Blue retro-reflective or semi-matt

Temporary sign number TR317P.
Indicates to the driver of a vehicle that a parking area is reserved for abnormal vehicles only.

R317P

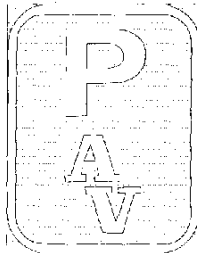

REGULATIONS
Road Traffic and Transport Act 22 of 1999
Road Traffic and Transport Regulations, 2001

R318P : Rickshaw parking reservation sign:

COLOURS:

Border, symbol and legend: White retro-reflective or semi-matt
 Background: Blue retro-reflective or semi-matt

Temporary sign number TR318P.
 Indicates to the driver of a vehicle that a parking area is reserved for rickshaws only.

R318P

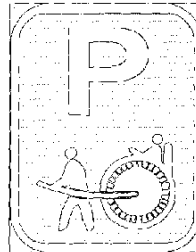

R319P : Tour bus parking reservation sign:

COLOURS:

Border, symbol & legend: White retro-reflective or semi-matt
 Background: Blue retro-reflective or semi-matt

Temporary sign number TR319P.
 Indicates to the driver of a vehicle that a parking area is reserved for tour buses only.

R319P

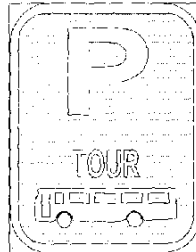

R320P : High occupancy vehicle parking reservation sign:

COLOUR:

Border: White retro-reflective or semi-matt
 Symbol: White retro-reflective or semi-matt
 Legend on symbol: Black semi-matt
 Background: Blue retro-reflective or semi-matt

Temporary sign number TR320P.
 Indicates to the driver of a vehicle that a parking area is reserved for high occupancy vehicles only.

R320P

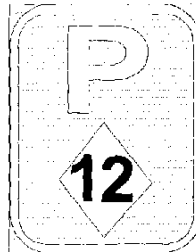

REGULATIONS
Road Traffic and Transport Act 22 of 1999
Road Traffic and Transport Regulations, 2001

R321P : Emergency services vehicles parking reservation sign:

COLOUR:

- Border & legend: White retro-reflective or semi-matt
- Symbols: White & red retro-reflective or semi-matt
- Background: Blue retro-reflective or semi-matt

Temporary sign number TR321P.
 Indicates to the driver of a vehicle that a parking area is reserved for emergency services vehicles only.

R321P

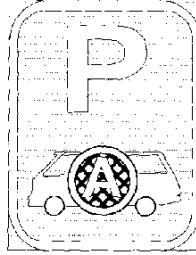

R322P(Nam) : Police vehicle parking reservation sign:

COLOURS:

- Border & legend: White retro-reflective or semi-matt
- Symbol: White, yellow, black & red retro-reflective or semi-matt
- Background: Blue retro-reflective or semi-matt

Temporary sign number TR322P(Nam).
 Indicates to the driver of a vehicle that a parking area is reserved for police vehicles only.

R322P(Nam)

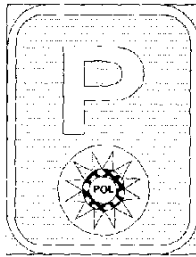

R323P : Vehicle conveying disabled persons parking reservation sign:

COLOURS:

- Border, symbol & legend: White retro-reflective or semi-matt
- Background: Blue retro-reflective or semi-matt

Temporary sign number TR323P.
 Indicates to the driver of a vehicle that a parking area is reserved for vehicles conveying disabled persons only.

R323P

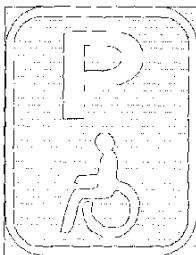

REGULATIONS
Road Traffic and Transport Act 22 of 1999
Road Traffic and Transport Regulations, 2001

R324P : Authorised vehicle parking reservation sign:

COLOURS:

Border, symbol & legend:	White retro-reflective or semi-matt
Legend on symbol:	Black semi-matt or appropriate colour retro-reflective or semi-matt
Background:	Blue retro-reflective or semi-matt

Temporary sign number TR324P.
 Indicates to the driver of a vehicle that a parking area is reserved for the authorised vehicles indicated on the sign only.

R324P

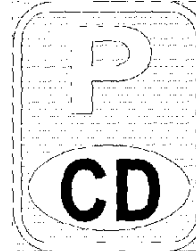

R325P and R326P : No sign allocated

R327P : Bus and minibus parking reservation sign:

COLOURS:

Border, symbol & legend:	White retro-reflective or semi-matt
Background:	Blue retro-reflective or semi-matt

Temporary sign number TR327P.
 Indicates to the driver of a vehicle that a parking area is reserved for buses and minibuses only.

R327P

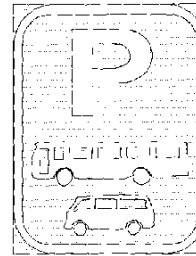

R328P to R329P : No sign allocated

R330P : Bus and midibus parking reservation sign:

COLOURS:

Border, symbol & legend:	White retro-reflective or semi-matt
Background:	Blue retro-reflective or semi-matt

Temporary sign number TR330P.
 Indicates to the driver of a vehicle that a parking area is reserved for buses and midibuses only.

R330P

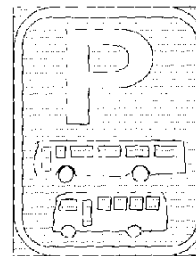

R331P to R332P : No sign allocated

REGULATIONS
Road Traffic and Transport Act 22 of 1999
Road Traffic and Transport Regulations, 2001

R333P : Bus, midibus and minibus parking reservation sign:

R333P

COLOURS:

Border, symbol & legend:	White retro-reflective or semi-matt
Background:	Blue retro-reflective or semi-matt

Temporary sign number TR333P.
Indicates to the driver of a vehicle that a parking area is reserved for buses, midibuses and minibuses only.

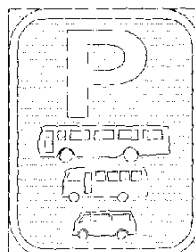

REGULATIONS
Road Traffic and Transport Act 22 of 1999
Road Traffic and Transport Regulations, 2001

E. Comprehensive Signs:

R401 : Dual-carriageway freeway begins sign:

R401

COLOURS:

Border: Red retro-reflective
 Symbol: White retro-reflective
 Background: Blue retro-reflective

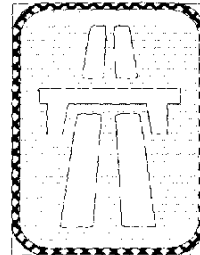

Indicates to the driver of a vehicle that a dual carriageway freeway begins and that regulation 343 applies on the section of the public road beyond such sign.

R402 : Single-carriageway freeway begins sign:

R402

COLOURS:

Border: Red retro-reflective
 Symbol: White retro-reflective
 Background: Blue retro-reflective

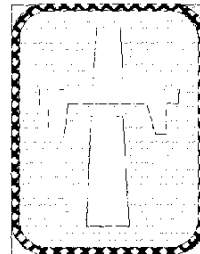

Indicates to the driver of a vehicle that a single carriageway freeway begins and that regulation 343 applies on the section of the public road beyond such sign.

R403 : Woonerf sign:

R403

COLOURS:

Border: Red retro-reflective
 Symbols: White retro-reflective
 Background: Blue retro-reflective

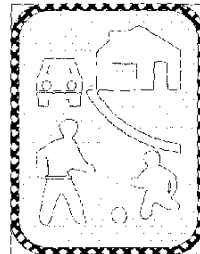

Indicates to the driver of a vehicle that, if he or she proceeds beyond such sign he or she shall -

- (a) not enter the area driving a vehicle with a gross vehicle mass exceeding 3 500 kg or a vehicle with more than 10 seats for passengers, except for local access or delivery;
- (b) yield right-of-way to pedestrians and children who may be in the roadway;
- (c) observe within the area a maximum speed limit of 30 kilometres per hour or as indicated by a supplementary sign; and
- (d) not enter the area by vehicle and drive through the area to exit at another point or the same point without breaking the journey.

REGULATIONS
Road Traffic and Transport Act 22 of 1999
Road Traffic and Transport Regulations, 2001

F. Exclusive Secondary Signs:

(R)501 : One period time limit sign:

(R)501

COLOURS:

As for the applicable regulatory sign.

Indicates to the driver of a vehicle that, when displayed below a regulatory sign, such regulatory sign only applies during the period of time indicated on the exclusive secondary sign.

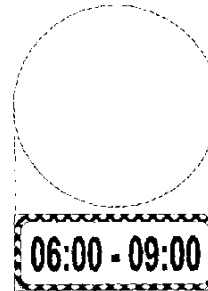

(R)502 : Two periods time limit sign:

(R)502

COLOURS:

As for the applicable regulatory sign.

Indicates to the driver of a vehicle that, when displayed below a regulatory sign, such regulatory sign only applies during the two periods of time indicated on the exclusive secondary sign.



(R)503 : Two periods or days time limit sign:

(R)503

COLOURS:

As for the applicable regulatory sign.

Indicates to the driver of a vehicle that, when displayed below a regulatory sign, such regulatory sign only applies during the period of time on weekdays and a different period of time on Saturdays indicated on the exclusive secondary sign.



REGULATIONS
Road Traffic and Transport Act 22 of 1999
Road Traffic and Transport Regulations, 2001

(R)504 : Three periods or days time limit sign:

(R)504

COLOURS:

As for the applicable regulatory sign.

Indicates to the driver of a vehicle that, when displayed below a regulatory sign, such regulatory sign applies during the two periods of time on weekdays and a different period of time on Saturdays, as indicated on the exclusive secondary sign.



(R)505 : Maximum stay during one period time limit sign:

(R)505

COLOURS:

As for the applicable regulatory sign.

Indicates to the driver of a vehicle that, when displayed below a regulatory sign, the time limit indicated by the exclusive secondary sign only applies during the period of time indicated thereon.



(R)506 : Maximum stay during two periods or days time limit sign:

(R)506

COLOURS:

As for the applicable regulatory sign.

Indicates to the driver of a vehicle that, when displayed below a regulatory sign, such regulatory sign only applies during the period of time on a weekday and a different period of time on a Saturday as indicated on the exclusive secondary sign.



(R)507 to (R)510 : No sign allocated

REGULATIONS
Road Traffic and Transport Act 22 of 1999
Road Traffic and Transport Regulations, 2001

(R)511 : Daytime condition sign:

COLOURS:

- Border: As for the applicable regulatory sign
- Symbol: Black semi-matt
- Background: White retro-reflective or semi-matt

Indicates to the driver of a vehicle that, when displayed below a regulatory sign, the significance of the regulatory sign applies during daytime only.

(R)511

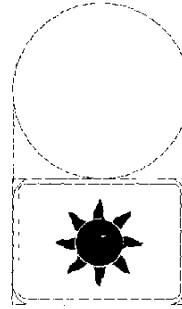

(R)512 : Night-time condition sign:

COLOURS:

- Symbol: White retro-reflective or semi-matt
- Background: Black semi-matt
- Border: As for the applicable regulatory sign

Indicates to the driver of a vehicle that, when displayed below a regulatory sign, the significance of the regulatory sign applies during night-time only.

(R)512



(R)513 to (R)519 : No sign allocated

(R)520 : Reserved movement left by vehicle class sign:

(R)521 : Reserved movement right by vehicle class sign:

(R)522 : Reserved movement to left and right by vehicle class sign:

COLOURS:

As for the applicable regulatory sign.

Indicates to the driver of a vehicle that, when displayed below a regulatory sign, the restriction indicated on the exclusive secondary sign applies to the direction indicated by the arrow.

(R)520 and (R)521

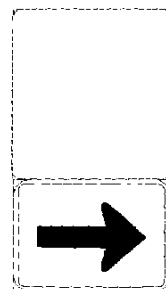

REGULATIONS
Road Traffic and Transport Act 22 of 1999
Road Traffic and Transport Regulations, 2001

(R)522

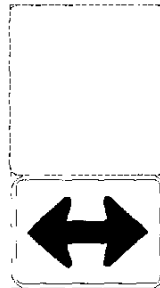

(R)523 : Pay and display sign:

COLOURS:

As for the applicable regulatory sign.

Indicates to the driver of a vehicle that, when displayed below a parking reservation sign, the use of the parking area is subject to payment at a pay station.

(R)523

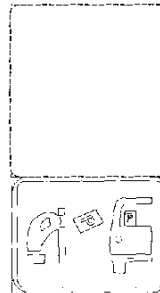

(R)524 to (R)529 : No sign allocated

(R)530 : Operator identity (logo) sign:
(R)531 : Operator identity (words) sign:

COLOURS:

As for the applicable regulatory sign.

Indicates to the driver of a vehicle that, when displayed below a regulatory sign, the significance of the regulatory sign applies to drivers of vehicles operated by the company, owner or organisation indicated by means of a logo or text on the exclusive secondary sign.

(R)530 and (R)531

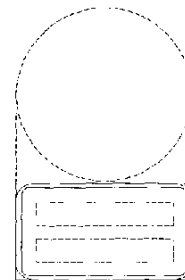

REGULATIONS
Road Traffic and Transport Act 22 of 1999
Road Traffic and Transport Regulations, 2001

(R)532 : Mass limit sign:

COLOURS:

As for the applicable regulatory sign.

Indicates to the driver of a vehicle that, when displayed below a regulatory sign, the significance of the regulatory sign applies to drivers of vehicles with a gross vehicle mass (GVM) exceeding the mass indicated in tonnes by the number on the exclusive secondary sign.

(R)532



(R)533 : Motor cycle engine size limit sign:

COLOURS:

As for the applicable regulatory sign.

Indicates to the driver of a vehicle that, when displayed below a regulatory sign, the significance of the regulatory sign applies to drivers of motor cycles with a rated engine capacity up to the capacity indicated in cubic centimetres, by the number on the exclusive secondary sign.

(R)533



(R)534 : Local access limit sign:

COLOURS:

As for the applicable regulatory sign.

Indicates to the driver of a vehicle that, when displayed below a regulatory sign, the reservation sign also permits access by road users to local public or local private property, located on a section of public road beyond that sign.

(R)534



(R)535 : Distance limit sign:

COLOURS:

As for the applicable regulatory sign.

Indicates to the driver of a vehicle that, when displayed below a regulatory sign, the significance of the regulatory sign applies for the distance indicated in metres or kilometres, by the number on the exclusive secondary sign, but the maximum distance which may be displayed, is five kilometres.

(R)535

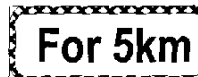

R536 to R539 : No sign allocated

REGULATIONS
Road Traffic and Transport Act 22 of 1999
Road Traffic and Transport Regulations, 2001

(R)540 : Maximum number of vehicles sign:

(R)540

COLOURS:

As for the applicable regulatory sign.

Indicates to the driver of a vehicle that, when displayed below a reservation sign, the reservation indicated on the sign is further restricted to a maximum number of vehicles as indicated by the number on the exclusive secondary sign.

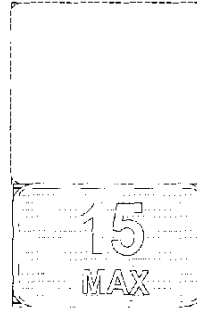

(R)541 to (R)559 : No sign allocated

(R)560 : Buses sign:

(R)560

COLOURS:

As for the applicable regulatory sign.

Indicates to the driver of a vehicle that, when displayed below a regulatory sign, the significance of the regulatory sign applies to buses only.

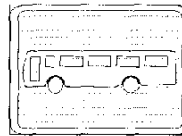

(R)561 : Pedal cycles sign:

(R)561

COLOURS:

As for the applicable regulatory sign.

Indicates to the driver of a vehicle that, when displayed below a regulatory sign, the significance of the regulatory sign applies to pedal cycles only.

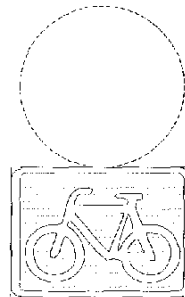

REGULATIONS
Road Traffic and Transport Act 22 of 1999
Road Traffic and Transport Regulations, 2001

(R)562 : Motor cycles sign:

COLOURS:

As for the applicable regulatory sign.

Indicates to the driver of a vehicle that, when displayed below a regulatory sign, the significance of the regulatory sign applies to motor cycles only.

(R)562

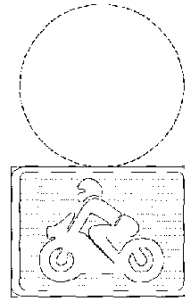

(R)563 : Motor car sign:

COLOURS:

As for the applicable regulatory sign.

Indicates to the driver of a vehicle that, when displayed below a regulatory sign, the significance of the regulatory sign applies to motor cars only.

(R)563

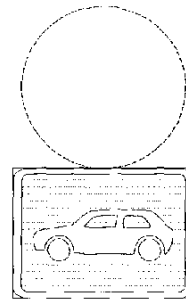

(R)564 : Taxi sign:

COLOURS:

As for the applicable regulatory sign.

Indicates to the driver of a vehicle that, when displayed below a regulatory sign, the significance of the regulatory sign applies to taxis only.

(R)564

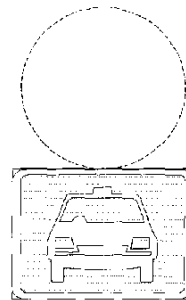

REGULATIONS
Road Traffic and Transport Act 22 of 1999
Road Traffic and Transport Regulations, 2001

(R)565 : Minibus sign:

COLOURS:

As for the applicable regulatory sign.

Indicates to the driver of a vehicle that, when displayed below a regulatory sign, the significance of the regulatory sign applies to minibuses only.

(R)565

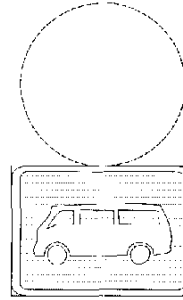

(R)566 : Midibus sign:

COLOURS:

As for the applicable regulatory sign.

Indicates to the driver of a vehicle that, when displayed below a regulatory sign, the significance of the regulatory sign applies to midibuses only.

(R)566

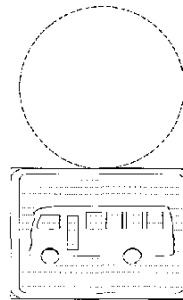

(R)567 : Delivery vehicle sign:

COLOURS:

As for the applicable regulatory sign.

Indicates to the driver of a vehicle that, when displayed below a regulatory sign, the significance of the regulatory sign applies to delivery vehicles only.

(R)567

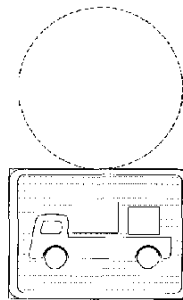

REGULATIONS
Road Traffic and Transport Act 22 of 1999
Road Traffic and Transport Regulations, 2001

(R)568 : Goods vehicle sign:

COLOURS:

As for the applicable regulatory sign.

Indicates to the driver of a vehicle that, when displayed below a regulatory sign, the significance of the regulatory sign applies to goods vehicles only.

(R)568

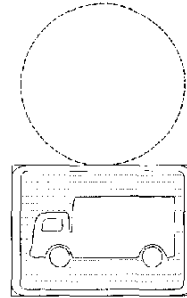

(R)569 : Goods vehicle over indicated GVM sign:

COLOURS:

As for the applicable regulatory sign.

Indicates to the driver of a vehicle that, when displayed below a regulatory sign, the significance of the regulatory sign applies to goods vehicles over indicated GVM only.

(R)569

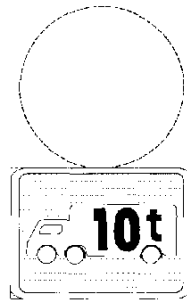

(R)570 : Construction vehicle sign:

COLOURS:

As for the applicable regulatory sign.

Indicates to the driver of a vehicle that, when displayed below a regulatory sign, the significance of the regulatory sign applies to construction vehicles only.

(R)570

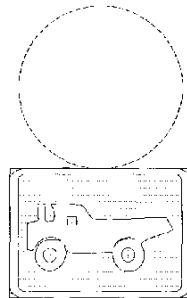

REGULATIONS
Road Traffic and Transport Act 22 of 1999
Road Traffic and Transport Regulations, 2001

(R)571 : Vehicles conveying dangerous goods:

(R)571

COLOURS:

As for the applicable regulatory sign.

Indicates to the driver of a vehicle that, when displayed below a regulatory sign, the significance of the regulatory sign applies to vehicles conveying dangerous goods only.

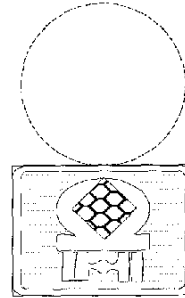

(R)572 : Abnormal vehicle sign:

(R)572

COLOURS:

As for the applicable regulatory sign.

Indicates to the driver of a vehicle that, when displayed below a regulatory sign, the significance of the regulatory sign applies to abnormal vehicles only.

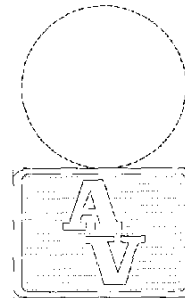

(R)573 : Rickshaw sign:

(R)573

COLOURS:

As for the applicable regulatory sign.

Indicates to the driver of a vehicle that, when displayed below a regulatory sign, the significance of the regulatory sign applies to rickshaws only.

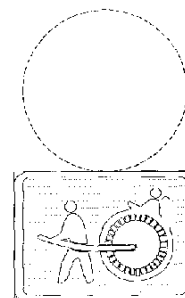

REGULATIONS
Road Traffic and Transport Act 22 of 1999
Road Traffic and Transport Regulations, 2001

(R)574 : Tour bus sign:

COLOURS:

As for the applicable regulatory sign.

Indicates to the driver of a vehicle that, when displayed below a regulatory sign, the significance of the regulatory sign applies to tour buses only.

(R)574

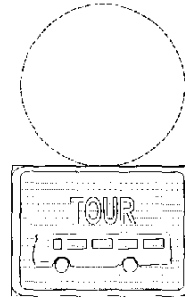

(R)575 : High occupancy vehicle sign:

COLOURS:

As for the applicable regulatory sign.

Indicates to the driver of a vehicle that, when displayed below a regulatory sign, the significance of the regulatory sign applies to high occupancy vehicles only.

(R)575

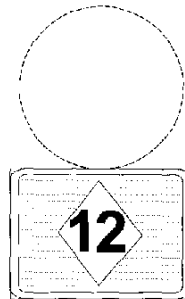

(R)576 : Emergency services vehicles sign:

COLOURS:

As for the applicable regulatory sign.

Indicates to the driver of a vehicle that, when displayed below a regulatory sign, the significance of the regulatory sign applies to emergency services vehicles only.

(R)576

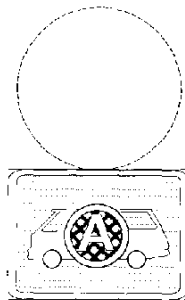

REGULATIONS
Road Traffic and Transport Act 22 of 1999
Road Traffic and Transport Regulations, 2001

(R)577 (NAM) : Police vehicle sign:

COLOURS:

As for the applicable regulatory sign.

Indicates to the driver of a vehicle that, when displayed below a regulatory sign, the significance of the regulatory sign applies to police vehicles only.

(R)577 (NAM)

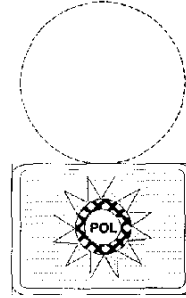

(R)578 : Vehicles conveying disabled persons sign:

COLOURS:

As for the applicable regulatory sign.

Indicates to the driver of a vehicle that, when displayed below a regulatory sign, the significance of the regulatory sign applies to vehicles conveying disabled persons only.

(R)578

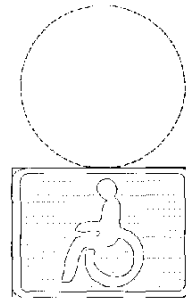

(R)579 : Authorised vehicle sign:

COLOURS:

As for the applicable regulatory sign.

Indicates to the driver of a vehicle that, when displayed below a regulatory sign, the significance of the regulatory sign only applies to the authorised vehicles indicated on the exclusive secondary sign.

(R)579

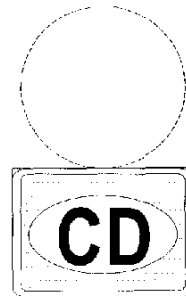

REGULATIONS
Road Traffic and Transport Act 22 of 1999
Road Traffic and Transport Regulations, 2001

(R)580 : Agricultural vehicle sign:

(R)580

COLOURS:

As for the applicable regulatory sign.

Indicates to the driver of a vehicle that, when displayed below a regulatory sign, the significance of the regulatory sign applies to agricultural vehicles only.

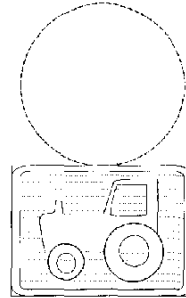

(R)581 : Animal-drawn vehicle sign:

(R)581

COLOURS:

As for the applicable regulatory sign.

Indicates to the driver of a vehicle that, when displayed below a regulatory sign, the significance of the regulatory sign applies to animal-drawn vehicles only.

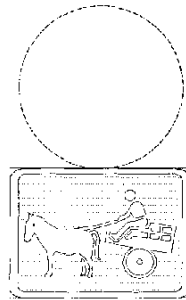

(R)582 : Towed vehicle sign:

(R)582

COLOURS:

As for the applicable regulatory sign.

Indicates to the driver of a vehicle that, when displayed below a regulatory sign, the significance of the regulatory sign applies to vehicles towing another vehicle only.

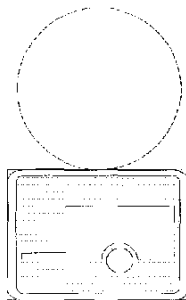

REGULATIONS
Road Traffic and Transport Act 22 of 1999
Road Traffic and Transport Regulations, 2001

(R)583 : Tram vehicle sign:

(R)583

COLOURS:

As for the applicable regulatory sign.

Indicates to the driver of a vehicle that, when displayed below a regulatory sign, the significance of the regulatory sign applies to trams only.

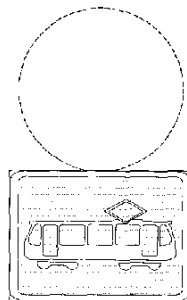

REGULATIONS
Road Traffic and Transport Act 22 of 1999
Road Traffic and Transport Regulations, 2001

G. Derestriction signs:

R600 Series: Derestriction signs:

- (a) A derestriction sign indicates to the driver of a vehicle that he or she does no longer have to comply with the regulatory message displayed under the red cancellation cross on the sign.
- (b) Examples of the use of a derestriction sign is shown.

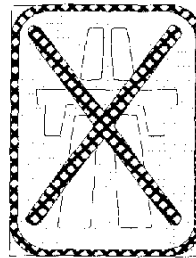
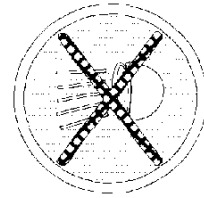
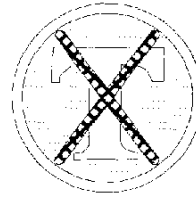
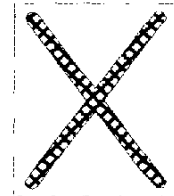
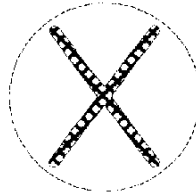

REGULATIONS
Road Traffic and Transport Act 22 of 1999
Road Traffic and Transport Regulations, 2001

H. Examples of selective restriction regulatory signs:

Examples of selective restriction regulatory signs are shown below:



REGULATIONS
Road Traffic and Transport Act 22 of 1999
Road Traffic and Transport Regulations, 2001

I. Examples of regulatory sign combinations:

Examples of regulatory sign combinations are shown below:

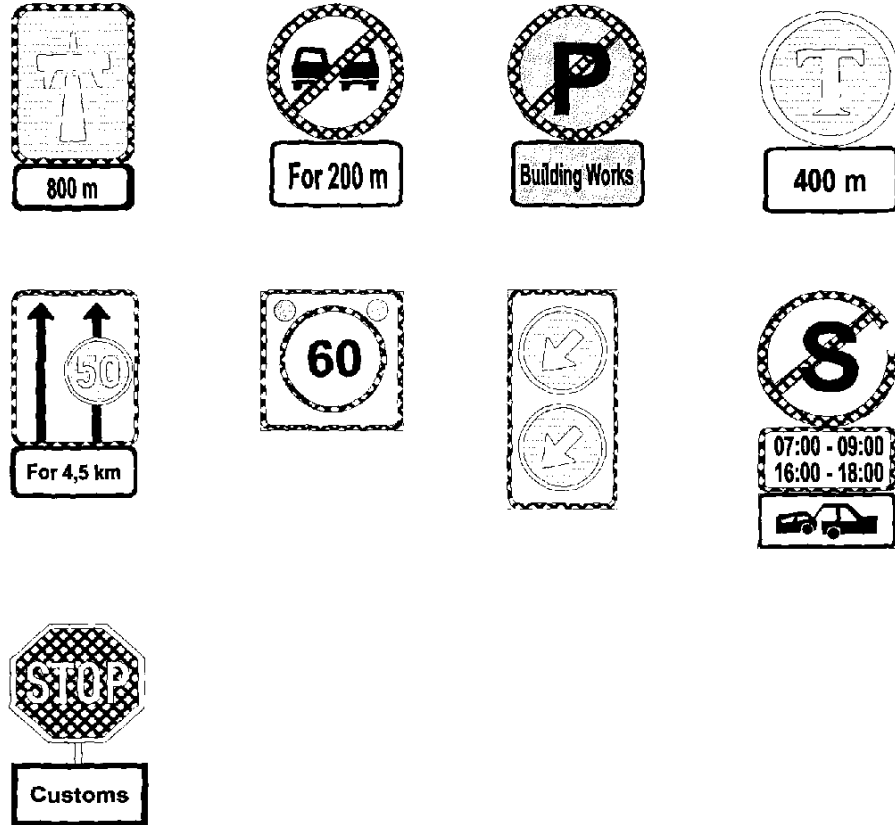

REGULATIONS
Road Traffic and Transport Act 22 of 1999
Road Traffic and Transport Regulations, 2001

Warning Signs

Warning signs are classified as follows:

- A Advance warning signs -
 - (i) road layout signs
 - (ii) direction of movement signs
 - (iii) symbolic signs

B Hazard marker signs

C Warning combination signs

A. Advance Warning Signs :

(i) Road Layout Signs:

W101 : Crossroad sign:

W101

COLOURS:

Triangle: Red retro-reflective
Symbol: Black semi-matt
Background: White retro-reflective



Temporary sign number TW101.
Warns a road user that a crossroad is ahead.

W102 : Priority crossroad sign:

W102

COLOURS:

Triangle: Red retro-reflective
Symbol: Black semi-matt
Background: White retro-reflective



Temporary sign number TW102.
Warns a road user that a crossroad is ahead and that he or she is travelling on an approach that has priority over intersecting approaches.

W103 : Secondary crossroad sign:

W103

COLOURS:

Triangle: Red retro-reflective
Symbol: Black semi-matt
Background: White retro-reflective



Temporary sign number TW103.
Warns a road user that a crossroad is ahead and that he or she is on an approach that does not have priority over intersecting approaches.

REGULATIONS
Road Traffic and Transport Act 22 of 1999
Road Traffic and Transport Regulations, 2001

W104 to W106 : T-junction and skew T-junctions sign:

COLOURS:

Triangle: Red retro-reflective
Symbol: Black semi-matt
Background: White retro-reflective

Temporary sign numbers TW104, TW105 and TW106.

Warns a road user that a T-junction or skew T-junction is ahead where road users are required to make a sharp or acute turn either to the left or to the right.

W104 and W105

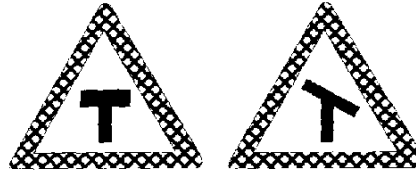

W106



W107 and W108 : Side road junction, sign:

COLOURS:

Triangle: Red retro-reflective
Symbol: Black semi-matt
Background: White retro-reflective

Temporary sign numbers TW107 and TW108.

Warns a road user that a side road junction from the left or right, is ahead.

W107 and W108

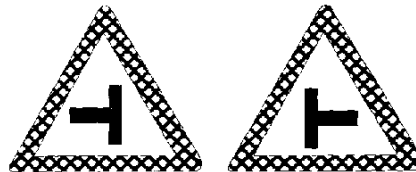

W109 and W110 : Staggered junction sign:

COLOURS:

Triangle: Red retro-reflective
Symbol: Black semi-matt
Background: White retro-reflective

Temporary sign numbers TW109 and TW110.

Warns a road user that a staggered junction is ahead.

W109 and W110

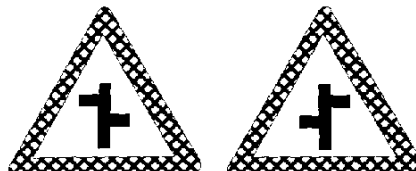

REGULATIONS
Road Traffic and Transport Act 22 of 1999
Road Traffic and Transport Regulations, 2001

W111 to W114 : Sharp junction sign:

COLOURS:

Triangle: Red retro-reflective
Symbol: Black semi-matt
Background: White retro-reflective

Temporary sign numbers TW111, TW112, TW113 and TW114.

Warns a road user that a sharp junction is ahead.

W111 and W112

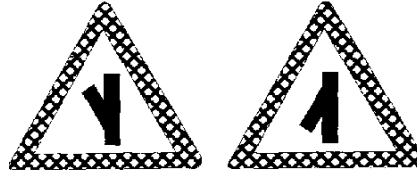

W113 and W114

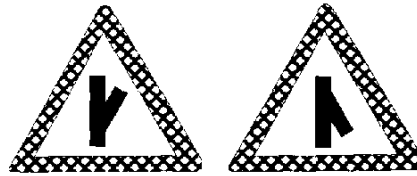

W115 : Y-junction sign:

COLOURS:

Triangle: Red retro-reflective
Symbol: Black semi-matt
Background: White retro-reflective

Temporary sign number TW115.

Warns a road user that a Y-junction is ahead.

W115

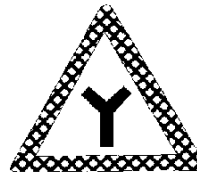

W116 and W117 : End of dual roadway sign:

COLOURS:

Triangle: Red retro-reflective
Symbol: Black semi-matt
Background: White retro-reflective

Temporary sign numbers TW116 and TW117.

Warns a road user that a one-way roadway is ending and that a roadway with traffic travelling in both directions is about to be entered.

W116 and W117

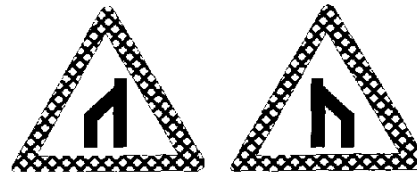

REGULATIONS
Road Traffic and Transport Act 22 of 1999
Road Traffic and Transport Regulations, 2001

W118 and W119 : Beginning of dual roadway sign:

COLOURS:

Triangle: Red retro-reflective
 Symbol: Black semi-matt
 Background: White retro-reflective

Temporary sign numbers TW118 and TW119.
 Warns a road user that a roadway with traffic travelling in both directions is ending and that a one-way roadway is about to be entered.

W118 and W119

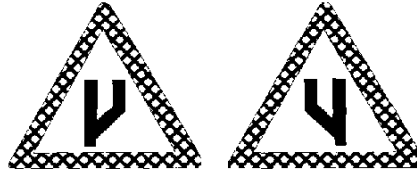

(ii) Direction of Movement Signs:

W201 : Mini circle or traffic circle sign:

COLOURS:

Triangle: Red retro-reflective
 Arrows: Black semi-matt
 Background: White retro-reflective

Temporary sign number TW201.
 Warns a road user that a mini circle or traffic circle is ahead.

W201

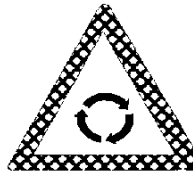

W202 and W203 : Gentle curve sign:

COLOURS:

Triangle: Red retro-reflective
 Arrow: Black semi-matt
 Background: White retro-reflective

Temporary sign numbers TW202 and TW203.
 Warns a road user of a gentle curve ahead to the right or to the left.

W202 and W203

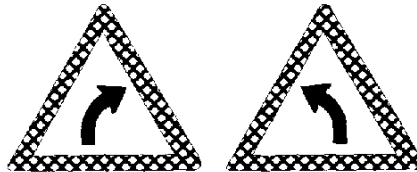

W204 and W205 : Sharp curve sign:

COLOURS:

Triangle: Red retro-reflective
 Arrow: Black semi-matt
 Background: White retro-reflective

Temporary sign numbers TW204 and TW205.
 Warns a road user of a sharp curve ahead to the right or to the left.

W204 and W205

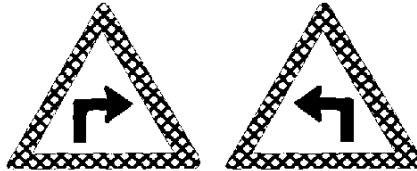

REGULATIONS
Road Traffic and Transport Act 22 of 1999
Road Traffic and Transport Regulations, 2001

W206 and W207 : Hairpin bend sign:

COLOURS:

Triangle: Red retro-reflective
Arrow: Black semi-matt
Background: White retro-reflective

Temporary sign numbers TW206 and TW207.
Warns a road user of a sharp u-shaped bend ahead to the right or to the left.

W206 and W207

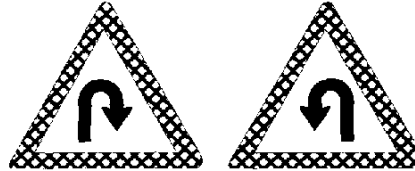

W208 and W209 : Winding road sign:

COLOURS:

Triangle: Red retro-reflective
Arrow: Black semi-matt
Background: White retro-reflective

Temporary sign numbers TW208 and TW209.
Warns a road user of a series of curves in the road ahead starting with a curve to the right or the left.

W208 and W209

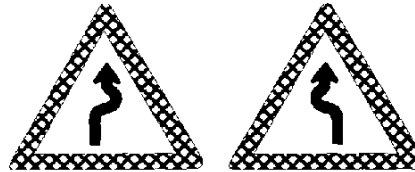

W210 and W211 : Combined curves sign:

COLOURS:

Triangle: Red retro-reflective
Arrow: Black semi-matt
Background: White retro-reflective

Temporary sign numbers TW210 and TW211.
Warns a road user of a combination of two sharp curves in opposite directions.

W210 and W211

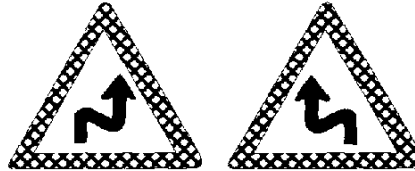

W212 : Two-way traffic sign:

COLOURS:

Triangle: Red retro-reflective
Arrow: Black semi-matt
Background: White retro-reflective

Temporary sign number TW212.
Warns a road user on a one-way roadway that the roadway ahead carries traffic in both directions.

W212

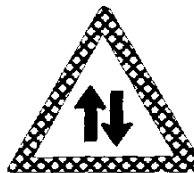

REGULATIONS
Road Traffic and Transport Act 22 of 1999
Road Traffic and Transport Regulations, 2001

W213 : Two-way traffic crossroad sign:

COLOURS:

Triangle: Red retro-reflective
 Arrow: Black semi-matt
 Background: White retro-reflective

Temporary sign number TW213.
 Warns a road user moving on a one-way roadway that the next crossroad carries two-way traffic.

W213

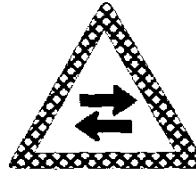

W214 and W215 : Lane ends sign:

COLOURS:

Triangle: Red retro-reflective
 Arrows: Black semi-matt
 Background: White retro-reflective

Temporary sign numbers TW214 and TW215.
 Warns a road user that a portion of the roadway on which he or she is travelling is reduced in width by a full lane from the right side or from the left side.

W214 and W215

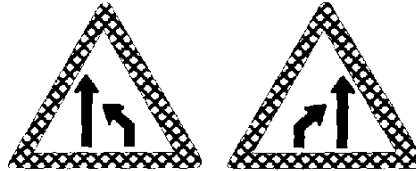

W216 to W218 : Concealed driveway sign:

COLOURS:

Triangle: Red retro-reflective
 Arrows: Black semi-matt
 Background: White retro-reflective

Temporary sign numbers TW216, TW217 and TW218.
 Warns a road user that other vehicles may enter the roadway ahead from driveways on the right, or the left, or both sides, in such a manner that, due to restricted sight distance, they may constitute a hazard and that extra caution should be exercised.

W216 and W217

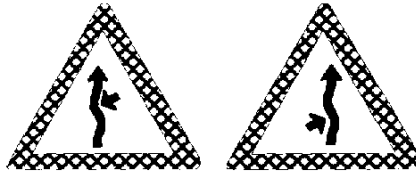

W218



(iii) Symbolic Signs:

W301 : Traffic signal ahead sign:

COLOURS:

Triangle: Red retro-reflective
 Symbol: Red, yellow & green retro-reflective on black semi-matt
 Background: White retro-reflective

Temporary sign number TW301.
 Warns a road user of the presence of a traffic signal ahead.

W301

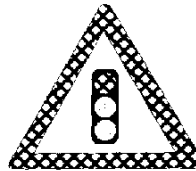

REGULATIONS
Road Traffic and Transport Act 22 of 1999
Road Traffic and Transport Regulations, 2001

W302 : Traffic control "STOP" ahead sign:

W302

COLOURS:

Triangle: Red retro-reflective
Symbol & legend: White & red retro-reflective
Background: White retro-reflective

Temporary sign number TW302.
Warns a road user of the presence of a stop sign R1 ahead.



W303 : Traffic control "YIELD" ahead sign:

W303

COLOURS:

Triangle: Red retro-reflective
Symbol: White & red retro-reflective
Background: White retro-reflective

Temporary sign number TW303.
Warns a road user of the presence of a yield sign R2 ahead.



TW304 : Traffic control ahead sign:

TW304

COLOURS:

Triangle: Red retro-reflective
Symbol: Black semi-matt
Background: Yellow retro-reflective

Warns a road user that there is a traffic officer ahead who is temporarily controlling traffic.



TW305 : School patrol ahead sign:

TW305

COLOURS:

Triangle: Red retro-reflective
Symbol: Black semi-matt and red & white retro-reflective
Background: Yellow retro-reflective

Warns a road user that a school patrol is temporarily operating ahead.



W306 : Pedestrian crossing sign:

W306

COLOURS:

Triangle: Red retro-reflective
Symbol: Black semi-matt
Background: White retro-reflective

Temporary sign number TW306.
Warns a road user of a marked pedestrian crossing ahead.



REGULATIONS
Road Traffic and Transport Act 22 of 1999
Road Traffic and Transport Regulations, 2001

W307 : Pedestrians sign:

W307

COLOURS:

Triangle: Red retro-reflective
Symbol: Black semi-matt
Background: White retro-reflective



Temporary sign number TW307.
Warns a road user of the possible presence of pedestrians ahead.

W308 : Children sign:

W308

COLOURS:

Triangle: Red retro-reflective
Symbol: Black semi-matt
Background: White retro-reflective



Temporary sign number TW308.
Warns a road user of the possible presence of children near schools, playgrounds, sports fields or other places ahead.

W309 : Cyclists sign:

W309

COLOURS:

Triangle: Red retro-reflective
Symbol: Black semi-matt
Background: White retro-reflective



Temporary sign number TW309.
Warns a road user of the possible presence of cyclists ahead.

W310 to W312 : Farm animals sign:

W310 to W312

COLOURS:

Triangle: Red retro-reflective
Symbol: Black semi-matt
Background: White retro-reflective

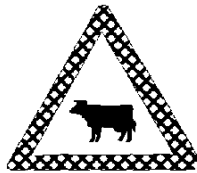

Temporary sign numbers TW310, TW311 and TW312.
Warns a road user of the possible presence of farm animals either crossing or straying onto the public road ahead.

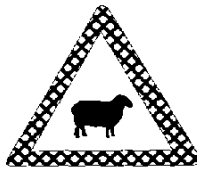

REGULATIONS
Road Traffic and Transport Act 22 of 1999
Road Traffic and Transport Regulations, 2001

W313 : Wild animals ahead sign:

W313

COLOURS:

Triangle: Red retro-reflective
Symbol: Black semi-matt
Background: White retro-reflective



Temporary sign number TW313.
Warns a road user of the possible presence of wild animals either crossing or straying onto the public road ahead.

W314 : Gate sign:

W314

COLOURS:

Triangle: Red retro-reflective
Symbol: Black semi-matt
Background: White retro-reflective



Warns a road user that the roadway ahead may be closed by a gate or that a railway crossing with gates, booms or barriers is ahead.

W315 to W317 : Motor gate sign:

W315 and W316

COLOURS:

Triangle: Red retro-reflective
Symbol: Black semi-matt
Background: White retro-reflective

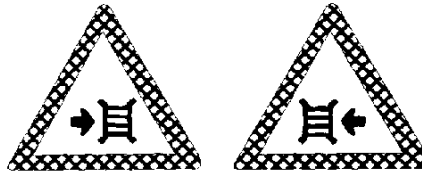

Warns a road user that a motor gate is ahead on the right side, the left side or in the centre of the roadway.

W317



W318 : Railway crossing sign:

W318

COLOURS:

Triangle: Red retro-reflective
Symbol: Black semi-matt
Background: White retro-reflective



Temporary sign number TW318.
Warns a road user that a railway crossing is ahead.

REGULATIONS
Road Traffic and Transport Act 22 of 1999
Road Traffic and Transport Regulations, 2001

W319 : Tunnel sign:

COLOURS:

Triangle: Red retro-reflective
 Symbol: Black semi-matt
 Background: White retro-reflective

Warns a road user of the presence of a tunnel over the roadway ahead.

W319



W320 : Height restriction sign:

COLOURS:

Triangle: Red retro-reflective
 Symbol & legend: Black semi-matt
 Background: White retro-reflective

Temporary sign number TW320.
 Warns a road user that the clearance of -
 (a) a height gauge located on a railway crossing ahead over which electrified high tension contact wires are installed; or
 (b) an overhead structure;
 is restricted in metres by the number indicated on the sign.

W320



W321 : Length restricted sign:

COLOURS:

Triangle: Red retro-reflective
 Symbol & legend: Black semi-matt
 Background: White retro-reflective

Temporary sign number TW321.
 Warns a road user that the permissible length of vehicles is restricted in metres by the number indicated on the sign.

W321

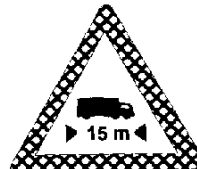

W322 and W323 : Steep ascent and descent sign:

COLOURS:

Triangle: Red retro-reflective
 Symbol: Black semi-matt
 Background: White retro-reflective

Temporary sign numbers TW322 and TW323.
 Warns a road user of a steep uphill or downhill ahead.

W322 and W323

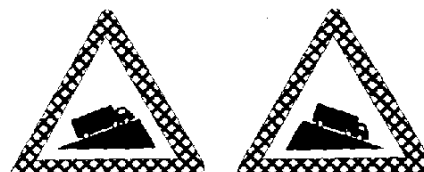

REGULATIONS
Road Traffic and Transport Act 22 of 1999
Road Traffic and Transport Regulations, 2001

W324 : Slow moving heavy vehicles sign:

W324

COLOURS:

Triangle: Red retro-reflective
Symbol: Black semi-matt
Background: White retro-reflective

Temporary sign number TW324.
Warns a road user that due to a steep downhill ahead, heavy vehicles may be travelling very slowly in a low gear.



W325 : Gravel road begins sign:

W325

COLOURS:

Triangle: Red retro-reflective
Symbol: Black semi-matt
Background: White retro-reflective

Temporary sign number TW325.
Warns a road user that the asphalt, tar or concrete road surface on which he or she is travelling is about to end and that the road surface will become gravel.

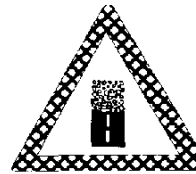

W326 : Narrow bridge sign:

W326

COLOURS:

Triangle: Red retro-reflective
Symbol: Black semi-matt
Background: White retro-reflective

Temporary sign number TW326.
Warns a road user that the width of the roadway is narrowed at a bridge on the roadway ahead.



W327 : One vehicle width structure sign:

W327

COLOURS:

Triangle: Red retro-reflective
Symbol: Black semi-matt
Background: White retro-reflective

Temporary sign number TW327.
Warns a road user that the width of the structure on the roadway ahead is less than five metres and that traffic must stop at the entrance thereto if a vehicle approaching from the opposite direction is already on the structure, or so close thereto as to constitute a danger.



REGULATIONS
Road Traffic and Transport Act 22 of 1999
Road Traffic and Transport Regulations, 2001

W328 : Road narrows from both sides sign:

W328

COLOURS:

Triangle: Red retro-reflective
Symbol: Black semi-matt
Background: White retro-reflective



Temporary sign number TW328.
Warns a road user that the roadway ahead narrows from both sides.

W329 and W330 : Road narrows from one side only sign:

W329 and W330

COLOURS:

Triangle: Red retro-reflective
Symbol: Black semi-matt
Background: White retro-reflective

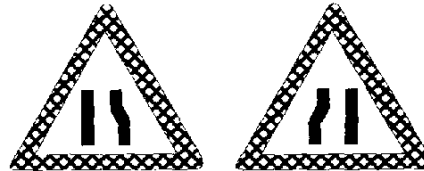

Temporary sign numbers TW329 and TW330.
Warns a road user that the roadway ahead narrows from the right or left side only.

W331 : Uneven roadway sign:

W331

COLOURS:

Triangle: Red retro-reflective
Symbol: Black semi-matt
Background: White retro-reflective



Temporary sign number TW331.
Warns a road user that there is a dip or ridge in the roadway or that the road surface is generally uneven or potholed.

W332 : Speed humps sign:

W332

COLOURS:

Triangle: Red retro-reflective
Symbol: Black semi-matt
Background: White retro-reflective

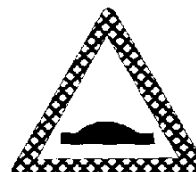

Temporary sign number TW332.
Warns a road user of speed humps on the roadway ahead.

REGULATIONS
Road Traffic and Transport Act 22 of 1999
Road Traffic and Transport Regulations, 2001

W333 : Slippery road sign:

W333

COLOURS:

Triangle: Red retro-reflective
Symbol: Black semi-matt
Background: White retro-reflective



Temporary sign number TW333.
Warns a road user of abnormally slippery conditions on the roadway ahead.

W334 and W335 : Falling rocks sign:

W334 and W335

COLOURS:

Triangle: Red retro-reflective
Symbol: Black semi-matt
Background: White retro-reflective

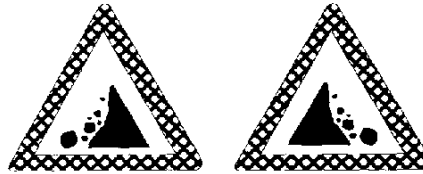

Temporary sign numbers TW334 and TW335.
Warns a road user of the possibility of falling or fallen rocks or stones on the right or left of the roadway ahead.

TW336 : Roadworks sign:

TW336

COLOURS:

Triangle: Red retro-reflective
Symbol: Black semi-matt
Background: Yellow retro-reflective



Warns a road user that temporary road construction, maintenance or related work is in progress ahead.

TW337 : Grader working sign:

TW337

COLOURS:

Triangle: Red retro-reflective
Symbol: Black semi-matt
Background: Yellow retro-reflective

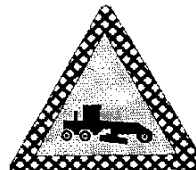

Warns a road user that a grader is working on the roadway ahead.

REGULATIONS
Road Traffic and Transport Act 22 of 1999
Road Traffic and Transport Regulations, 2001

TW338 : Loose stones sign:

TW338

COLOURS:

Triangle: Red retro-reflective
Symbol: Black semi-matt
Background: Yellow retro-reflective



Warns a road user of the presence of loose stones or gravel on the roadway ahead.

W339 : General warning sign:

W339

COLOURS:

Triangle: Red retro-reflective
Symbol: Black semi-matt
Background: White retro-reflective



Temporary sign number TW339.
Warns a road user that there is a hazard of a general, random or variable nature on the roadway ahead.

TW340 and TW341 : Surface step sign:

TW340 and TW341

COLOURS:

Triangle: Red retro-reflective
Symbol: Black semi-matt
Background: Yellow retro-reflective

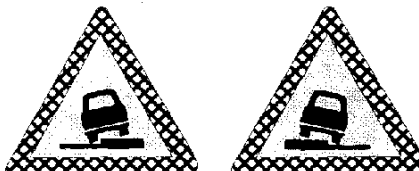

Warns a road user of a hazardous change in the surface of the roadway.

TW342 : Soft shoulder sign:

TW342

COLOURS:

Triangle: Red retro-reflective
Symbol: Black semi-matt
Background: Yellow retro-reflective



Warns a road user that the material of the shoulder of the roadway is softer than would be reasonably expected and constitutes a hazard to anyone wishing to pull off the roadway.

REGULATIONS
Road Traffic and Transport Act 22 of 1999
Road Traffic and Transport Regulations, 2001

TW343 : "Stop/Go" control ahead sign:

TW343

COLOURS:

Triangle: Red retro-reflective
 Symbol & legend: Red & white retro-reflective & black semi-matt
 Background: Yellow retro-reflective



Warns a road user that traffic ahead is being temporarily controlled by a portable STOP/GO sign R1.5.

TW344 and TW345 : Construction vehicles crossing sign:

TW344 and TW345

COLOURS:

Triangle: Red retro-reflective
 Symbol: Black semi-matt
 Background: White retro-reflective

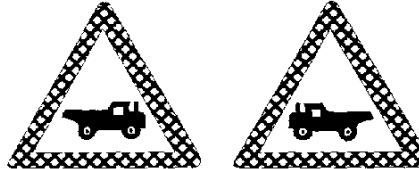

Temporary sign numbers TW344 and TW345.
 Warns a road user that construction vehicles regularly cross or enter the roadway ahead from the left or right side.

W346 : Emergency flashing light sign:

W346

COLOURS:

Triangle: Red retro-reflective
 Symbol: Yellow flashing light
 Background: White retro-reflective



Temporary sign number TW346.
 Warns a road user of a hazard ahead by means of an intermittent flashing yellow circular light within the warning sign.

TW347 : Temporary police flashing light sign:

TW347

COLOURS:

Triangle: Red retro-reflective
 Symbol: Blue flashing light
 Background: Yellow retro-reflective

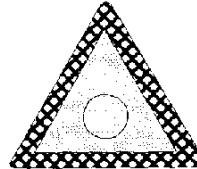

Warns a road user of the presence of police ahead at a temporary stop sign R1, or warns of an accident site or similar occurrence where the police are present.

REGULATIONS
Road Traffic and Transport Act 22 of 1999
Road Traffic and Transport Regulations, 2001

W348 : Jetty edge or river-bank sign:

W348

COLOURS:

Triangle: Red retro-reflective
Symbol: Black semi-matt
Background: White retro-reflective

Warns a road user that the roadway ahead leads to a jetty edge or a river bank.



W349 : Crosswind sign:

W349

COLOURS:

Triangle: Red retro-reflective
Legend: Black semi-matt
Background: White retro-reflective

Temporary sign number TW349.
Warns a road user of the possibility of a severe crosswind ahead which is capable of deflecting a vehicle from its path.



W350 : Drift sign:

W350

COLOURS:

Triangle: Red retro-reflective
Symbol: Black semi-matt
Background: White retro-reflective

Temporary sign number TW350.
Warns a road user of a drift ahead which may contain water, rock outcrops or loose material.



W351 : Low flying aircraft sign:

W351

COLOURS:

Triangle: Red retro-reflective
Symbol: Black semi-matt
Background: White retro-reflective

Warns a road user of the possibility of the presence of low flying aircraft in the vicinity of the roadway.



REGULATIONS
Road Traffic and Transport Act 22 of 1999
Road Traffic and Transport Regulations, 2001

W352 : Agricultural vehicle sign:

W352

COLOURS:

Triangle: Red retro-reflective
Symbol: Black semi-matt
Background: White retro-reflective

Warns a road user that slow moving agricultural vehicles regularly cross or enter the roadway ahead.



TW353 : Accident ahead sign:

TW353

COLOURS:

Triangle: Red retro-reflective
Symbol: Black semi-matt
Background: Yellow retro-reflective

Warns a road user that there is an accident ahead.



W354 : Reduced visibility sign:

W354

COLOURS:

Triangle: Red retro-reflective
Symbol: Black semi-matt
Background: White retro-reflective and black semi-matt hatched

Temporary sign number TW354.
Warns a road user of the possibility of reduced visibility ahead which might cause a hazard to road users.



W355 : Congestion sign:

W355

COLOURS:

Triangle: Red retro-reflective
Symbol: Black semi-matt
Background: White retro-reflective

Temporary sign number TW355.
Warns a road user of the possibility of congestion on the public road ahead.

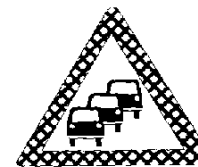

REGULATIONS
Road Traffic and Transport Act 22 of 1999
Road Traffic and Transport Regulations, 2001

W356 : Horses and riders sign:

W356

COLOURS:

Triangle: Red retro-reflective
Symbol: Black semi-matt
Background: White retro-reflective

Temporary sign number TW356.
Warns a road user of the possible presence of horses and riders on the public road ahead.



W357 : Elephant sign:

W357

COLOURS:

Triangle: Red retro-reflective
Symbol: Black semi-matt
Background: White retro-reflective

Temporary sign number TW357.
Warns a road user of the possible presence of elephants on the public road ahead.



W358 : Warthog sign:

W358

COLOURS:

Triangle: Red retro-reflective
Symbol: Black semi-matt
Background: White retro-reflective

Temporary sign number TW358.
Warns a road user of the possible presence of warthogs on the public road ahead.



W359 : Hippopotamus sign:

W359

COLOURS:

Triangle: Red retro-reflective
Symbol: Black semi-matt
Background: White retro-reflective

Temporary sign number TW359.
Warns a road user of the possible presence of hippopotamus on the public road ahead.



REGULATIONS
Road Traffic and Transport Act 22 of 1999
Road Traffic and Transport Regulations, 2001

W360 : Width restriction sign:

W360

COLOURS:

Triangle: Red retro-reflective
Symbol: Black semi-matt
Background: White retro-reflective

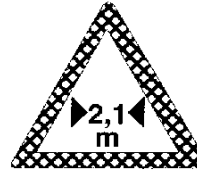

Temporary sign number TW360.
Warns a road user of the overall width of vehicles is restricted as indicated on the sign in metres by means of a number.

W361 : Electrical shock sign:

W361

COLOURS:

Triangle: Red retro-reflective
Symbol: Black semi-matt
Background: White retro-reflective

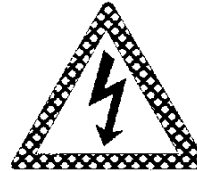

Temporary sign number TW361.
Warns a road user of the possibility of electrical shock from the overhead cables where such sign is displayed.

W362 : Tram sign:

W362

COLOURS:

Triangle: Red retro-reflective
Symbol: Black semi-matt
Background: White retro-reflective

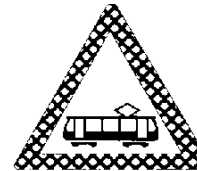

Warns a road user of the presence of trams on the public road ahead.

W363 : Gravel road ends sign:

W363

COLOURS:

Triangle: Red retro-reflective
Symbol: Black semi-matt
Background: White retro-reflective



Temporary sign number TW363.
Warns a road user that the gravel road on which he or she is travelling is about to end and that the road surface will become asphalt, tar or concrete.

REGULATIONS
Road Traffic and Transport Act 22 of 1999
Road Traffic and Transport Regulations, 2001

B. Hazard Marker Signs:

W401 and W402 : Danger plate sign:

W401 and W402

COLOURS:

White retro-reflective on red retro-reflective

Warns a road user of an obstruction or alteration in the roadway alignment to the left or right side of the roadway.

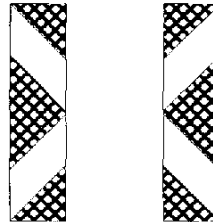

TW401 and TW402 : Delineator plate sign:

TW401 and TW402

COLOURS:

Yellow retro-reflective on black semi-matt

Warns a road user of a temporary obstruction or alteration in the roadway alignment to the left or right side of the roadway.

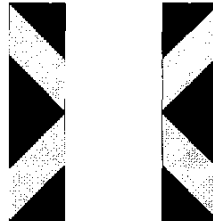

W403 and W404 : Railway crossing sign:

W403 and W404

COLOURS:

Outer cross: Red retro-reflective
 Inner cross: White retro-reflective

Warns a road user of one or more railway lines at a railway crossing.

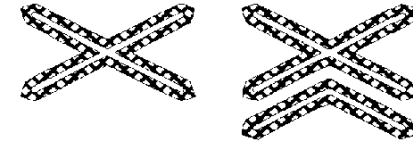

W405 to W408 : Sharp curve chevron sign:

W405 to W406

COLOURS:

Arrow: Red retro-reflective
 Background: White retro-reflective

Temporary sign numbers TW405, TW406, TW407 and TW408.
 Warns a road user that the roadway ahead is diverted to the right or left owing to a sudden change of direction.

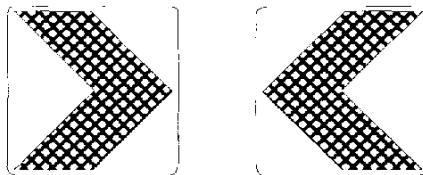

W407 and W408



REGULATIONS
Road Traffic and Transport Act 22 of 1999
Road Traffic and Transport Regulations, 2001

W409 : T-junction chevron sign:

COLOURS:

Arrow: Red retro-reflective
 Background: White retro-reflective

Temporary sign number TW409.
 Warns a road user that the roadway does not continue beyond the junction and that a turn must be made to the right or left.

W409

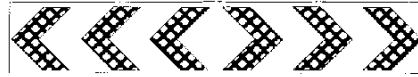

W410 : Dead end or road closed chevron sign:

COLOURS:

Arrow: Red retro-reflective
 Background: White retro-reflective

Temporary sign number TW410.
 Warns a road user that the roadway does not continue beyond the sign.

W410

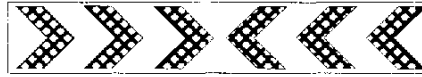

W411 : Boom barricade sign:

COLOURS:

Symbols: Red retro-reflective
 Background: White retro-reflective

Warns a road user that a portion of the roadway is temporarily closed to traffic.

W411



TW411 : Temporary barricade sign:

COLOURS:

Symbols: Red retro-reflective
 Background: Yellow retro-reflective

Warns a road user that a portion of the roadway is temporarily closed to traffic.

TW411



TW412 : Traffic signal out of order sign:

COLOURS:

Cross: Black semi-matt
 Border: Yellow retro-reflective

Warns a road user that the traffic signals ahead are temporarily out of order.

TW412

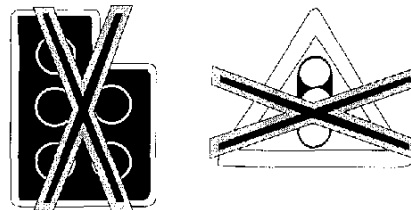

REGULATIONS
Road Traffic and Transport Act 22 of 1999
Road Traffic and Transport Regulations, 2001

W413 : Gore plate sign:

W413

COLOURS:

Red retro-reflective on white retro-reflective

Temporary sign number TW413.

Warns a road user of a gore in the roadway ahead.

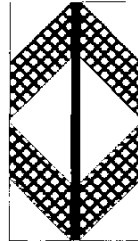

W414 : Gore chevron sign:

W414

COLOURS:

Red retro-reflective on white retro-reflective

Temporary sign number TW414.

Warns a road user of a physical separation in the road ahead which he or she must pass to the left or right.



W415 : Overhead danger plate sign:

W415

COLOURS:

Red retro-reflective on white retro-reflective

Temporary sign number TW415.

Warns a road user of an overhead obstruction above the roadway.



C. Warning Combination Signs:

Examples of warning combination signs are as follows:

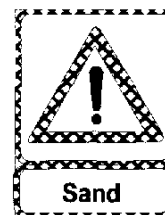
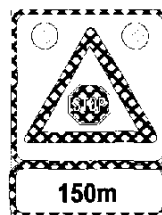
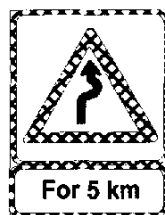

REGULATIONS
Road Traffic and Transport Act 22 of 1999
Road Traffic and Transport Regulations, 2001

(iii) Guidance Signs

(1) Guidance signs are classified as follows:

- A Location signs
- B Route marker signs
- C Direction signs
- D Freeway direction signs
- E Tourism direction signs
- F Local direction signs
- G Diagrammatic signs

- (2) A street name sign GL1 may be provided in any combination of colours, provided that the border and legend are in a dark colour and the background is a light colour.
- (3) A town or city name sign GL3 may include a full colour depiction of the town's or city's crest.
- (4) A national, regional or district border sign GL5 may include a full colour depiction of the national, regional or district crest.
- (5) A route name sign GL7 must incorporate a symbol indicating the class of freeway, a toll route symbol or end of toll route symbol, as the case may be.
- (6) A metropolitan route marker sign may display a unique internal shape identified with the specific metropolitan area within which the route lies, as shown by sign GE 12.
- (7) A main or district road is indicated by a horizontal rectangular shape as shown by sign GE 13.
- (8) A secondary route is indicated by diamond shape as shown by sign GE 14.
- (9) A major route is indicated by a pentagon shape as shown by sign GE 15.
- (10) An interchange number may be indicated in black on white in the top left hand corner of an advance direction sign GD1, freeway exit direction signs GA1, GA2, GA2/3, GA3 and GA4, freeway crossroad sign GB1 and tourism freeway advance sign GF1.
- (11) In an urban or metropolitan area the name of the local authority in whose region a freeway interchange is located may be indicated in black on white at the top of freeway exit direction signs GA 1, GA2, GA2/3, GA3, and freeway crossroad sign GB1, but such a place name may not be displayed on signs serving an interchange between two freeways.
- (12) In an urban or metropolitan area the principal destination name may be the name of the intersecting cross-street.
- (13) In an urban area the name of the intersecting cross street may be indicated in black on white at the top of an advance off-ramp terminal direction sign GA5 and an off-ramp terminal direction sign GA6.
- (14) AT-junction chevron sign W409 must be mounted below an off-ramp terminal direction sign GA6. The length of sign W409 must equal the length of sign GA6.

REGULATIONS
Road Traffic and Transport Act 22 of 1999
Road Traffic and Transport Regulations, 2001

- (15) An arrangement, or cluster of upward pointing arrows as used on overhead advance direction signs GD12 to GD 16 and on overhead supplementary exit/through direction sign GC3U, overhead advance off-ramp direction sign GC5U or overhead collector-distributor through direction sign GC7U must accurately represent the number of exit lanes, any shared lanes and the number of through or straight-on lanes. The shape of the arrows must show any significant change in direction existing in any section of lane as indicated by such signs.
- (16) A tourism lay-by advance sign GF5 and a lay-by turn-in sign GF6 may be used with an appropriate symbol for lay-bys other than rest areas.
- (17) Tourism information sign GF16 may be incorporated into an information board.
- (18) Any diagrammatic sign may be displayed in an overhead position. The number of such sign is derived by placing the number 6 in front of the normal sign numerals.
- (19) A distance, representing the distance that the sign referred to in paragraph (18) is displayed in advance of the point on the roadway to which it applies, may be located below the overhead diagrammatic portion of the sign but within the outer border. The number of such sign denoting such distance is derived by placing the letter D after the sign number.
- (20) Local direction signs may be used to indicate destinations in urban areas.
- (21) Prescribed symbols may be used to reduce the text for the description of a destination.
- (22) The guidance signs shown in these regulations are only examples of such types of signs.

REGULATIONS
Road Traffic and Transport Act 22 of 1999
Road Traffic and Transport Regulations, 2001

A. Location Signs:

GL1 : Street name sign:

GL1

COLOURS:

Border: Black semi-matt
Legend: Black semi-matt
Background: White semi-matt or retro-reflective

INDEPENDENCE AVENUE

GL2 : Suburb name sign:

GL2

COLOURS:

Border: Black semi-matt
Legend: Black semi-matt
Background: White semi-matt or retro-reflective

TAMARISKIA

GL3 : Town or city name sign:

GL3

COLOURS:

Border: Black semi-matt
Legend: Black semi-matt
Background: White semi-matt or retro-reflective

TSUMEB

GL4 : River name sign:

GL4

COLOURS:

Border: Black semi-matt
Legend: Black semi-matt
Symbol: Blue retro-reflective
Background: White retro-reflective

KUISEB

A symbol consisting of three wavy horizontal lines representing a river, located below the text 'KUISEB' in the sign.

REGULATIONS
Road Traffic and Transport Act 22 of 1999
Road Traffic and Transport Regulations, 2001

GL5 : National, regional or district border sign:

GL5

COLOURS:

Border: Black semi-matt
Legend: Black semi-matt
Background: White semi-matt or retro-reflective



GL6 : Geographical location sign:

GL6

COLOURS:

Border: Black semi-matt
Legend: Black semi-matt
Background: White semi-matt or retro-reflective



GL7 : Route name sign:

GL7

COLOURS:

Border: Black semi-matt
Legend: Black semi-matt
Symbol: Black semi-matt or black semi-matt on yellow retro-reflective
Background: White retro-reflective



GL8 : Interchange name sign:

GL8

COLOURS:

Border: Black semi-matt
Legend: Black semi-matt
Symbol: Black semi-matt
Background: White semi-matt or retro-reflective



REGULATIONS
Road Traffic and Transport Act 22 of 1999
Road Traffic and Transport Regulations, 2001

Guidance Sign Symbols:

GLS1 to GLS7 : Location sign symbols

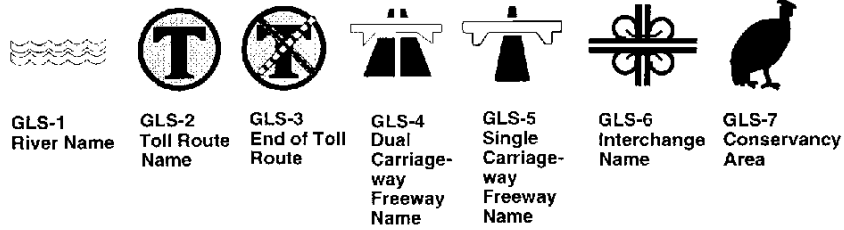

B. Route Marker Signs:

GE1 to GE4 : Advance trailblazer sign:

GE1 to GE4

COLOURS:

Border & arrow: White retro-reflective
 Legend: Yellow retro-reflective
 Symbol: White retro-reflective
 Background: Blue or green retro-reflective

Temporary sign numbers TGE1, TGE2, TGE3 and TGE4.

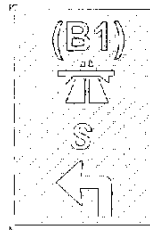

GE5 to GE 8 : Trailblazer sign:

GE5 to GE8

COLOURS:

Border & arrow: White retro-reflective
 Legend: Yellow retro-reflective
 Symbol: White retro-reflective
 Background: Blue or green retro-reflective

Temporary sign numbers TGE5, TGE6, TGE7 and TGE8.

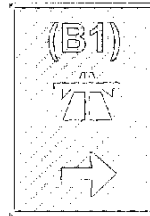

GE9 : Advance transport trailblazer sign:

GE9

COLOURS:

Border & arrow: White retro-reflective
 Symbol: White retro-reflective
 Background: Green retro-reflective

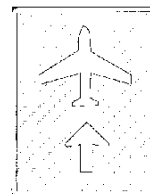

REGULATIONS
Road Traffic and Transport Act 22 of 1999
Road Traffic and Transport Regulations, 2001

GE10 : Transport trailblazer sign:

GE10

COLOURS:

Border & arrow: White retro-reflective
Symbol: White retro-reflective
Background: Green retro-reflective



GE11 : Map-type advance trailblazer sign:

GE11

COLOURS:

Border & arrow: White retro-reflective
Legend: Yellow retro-reflective
Background: Blue or green retro-reflective

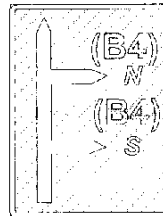

GE12 to GE15 : Confirmation route marker sign:

GE12 and GE13

COLOURS:

Border: White retro-reflective
Legend: Yellow retro-reflective
Background: Blue or green retro-reflective

Temporary sign numbers TGE12, TGE13, TGE14 and TGE15.

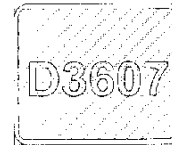
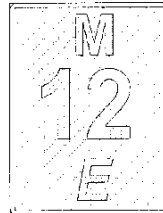

GE14 and GE15

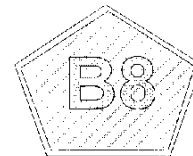
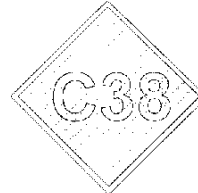

REGULATIONS
Road Traffic and Transport Act 22 of 1999
Road Traffic and Transport Regulations, 2001

GE12.1 and GE12.2 to GE15.1 and GE15.2:
Direction route marker sign:

COLOURS:

Border & arrow: White retro-reflective
 Legend: Yellow retro-reflective
 Background: Blue or green retro-reflective

Temporary sign numbers TGE12.1 and TGE12.2 to TGE15.1 and TGE15.2.

GE12.1 and GE12.2 to GE15.1 and GE15.2

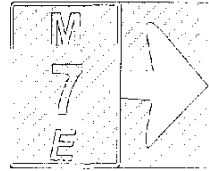

GE12.3, GE12.4 and GE12.5 to GE15.3, GE15.4 and GE15.5: Advance direction route marker sign:

COLOURS:

Border & arrow: White retro-reflective
 Legend: Yellow retro-reflective
 Background: Blue or green retro-reflective

Temporary sign numbers TGE12.3, TGE12.4 and TGE12.5 to TGE15.3, TGE15.4 and TGE15.5.

GE12.3, GE12.4 and GE12.5 to GE15.3, GE15.4 and GE15.5

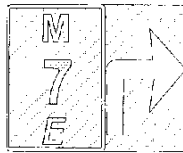

GE12.6 to GE12.8 : Overhead advance route marker sign:

COLOURS:

Border & arrow: White retro-reflective
 Legend: Yellow retro-reflective
 Background: Green retro-reflective

GE12.6 to GE12.8

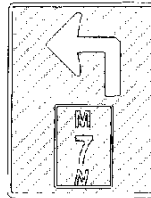

GE16 to GE16.5 : Alternative route marker sign:

COLOURS:

Border: White retro-reflective
 Legend: Yellow retro-reflective
 Symbol: Black semi-matt on yellow retro-reflective
 Background: Green retro-reflective

GE16 to GE16.5

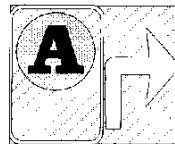

REGULATIONS
Road Traffic and Transport Act 22 of 1999
Road Traffic and Transport Regulations, 2001

GE17 to GE17.5 : Bicycle route marker sign:

GE17 to GE17.5

COLOURS:

Border: White retro-reflective
Legend: Yellow retro-reflective
Symbol: White retro-reflective
Background: Green retro-reflective

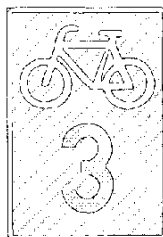

GE18 to GE18.5 : Tourism route marker sign:

GE18 to GE18.5

COLOURS:

Border: White retro-reflective
Legend: Yellow retro-reflective
Symbol: White retro-reflective
Background: Brown semi-matt or retro-reflective



GE19 to GE19.5 : SADC route marker sign:

GE19 to GE19.5

COLOURS:

Border: Blue retro-reflective or semi-matt
Route number: Orange retro-reflective
Symbol: Green retro-reflective
Background: Blue retro-reflective

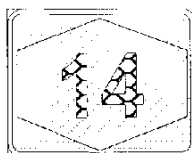

REGULATIONS
Road Traffic and Transport Act 22 of 1999
Road Traffic and Transport Regulations, 2001

C. Direction Signs:

GD1 : Stack-type advance direction sign:

COLOURS:

Border & arrow: White retro-reflective
 Route number: Yellow retro-reflective
 Legend: White retro-reflective
 Background: Green semi-matt or retro-reflective

Temporary sign number TGD1.

GD1



GD2 : Stack-type direction sign:

COLOURS:

Border & arrow: White retro-reflective
 Route number: Yellow retro-reflective
 Legend: White retro-reflective
 Background: Green semi-matt or retro-reflective

Temporary sign number TGD2.

GD2



TGD2-D : Detour direction sign:

COLOURS:

Border & arrow: Black semi-matt
 Symbol: Black semi-matt
 Background: Yellow retro-reflective

TGD2-D

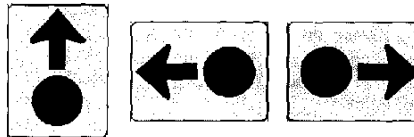

GD3 : Confirmation sign:

COLOURS:

Border: White retro-reflective
 Route number: Yellow retro-reflective
 Legend: White retro-reflective
 Background: Green semi-matt or retro-reflective

Temporary sign number TGD3.

GD3



REGULATIONS
Road Traffic and Transport Act 22 of 1999
Road Traffic and Transport Regulations, 2001

GD4 : Fingerboard sign:

COLOURS:

Border, symbol & legend: White retro-reflective
 Background: Green semi-matt or retro-reflective

Temporary sign number TGD4.

GD4



GD5 to GD9 : Map-type advance direction sign:

COLOURS:

Border & arrow: White retro-reflective
 Route number: Yellow retro-reflective
 Legend: White retro-reflective
 Background: Green semi-matt or retro-reflective

Temporary sign numbers TGD5, TGD6, TGD7, TGD8 and TGD9.

GD5 to GD9



GD10 : Overhead advance direction sign:

COLOURS:

Border & arrow: White retro-reflective
 Route number: Yellow retro-reflective
 Legend: White retro-reflective
 Background: Green retro-reflective

GD10

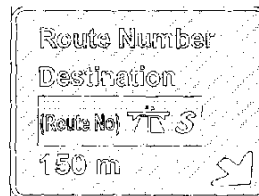

GD11 : Overhead direction sign:

COLOURS:

Border & arrow: White retro-reflective
 Route number: Yellow retro-reflective
 Legend: White retro-reflective
 Background: Green retro-reflective

GD11

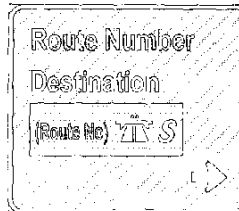

REGULATIONS
Road Traffic and Transport Act 22 of 1999
Road Traffic and Transport Regulations, 2001

GD12 to GD16 : Overhead advance direction sign:

COLOURS:

- Border, symbol & arrow: White retro-reflective
- Route number: Yellow retro-reflective
- Legend: White retro-reflective
- Background: Blue or green retro-reflective

GD12 to GD17



GDS1 to GDS22 : Direction sign symbols



GDS-1
Railway Station



GDS-2
Bus Terminus



GDS-3
Airport

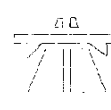

GDS-4
Freeway
(Class A)



GDS-5
Freeway
(Class A-2)



GDS-6
Power Station



GDS-7
Industrial Area



GDS-8
City Centre/Central
Business District



GDS-9
Toll Route



GDS-10
Alternative Route



GDS-11
Heliport



GDS-12
Mine

REGULATIONS
Road Traffic and Transport Act 22 of 1999
Road Traffic and Transport Regulations, 2001



GDS-13
Harbour



GDS-14
Shopping Centre



GDS-15
Library



GDS-16
Bicycle Route



GDS-17
Park 'n Ride (Train)

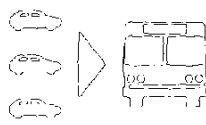

GDS-18
Park 'n Ride (Bus)



GDS-19 (Nam)
Pick-up Point



GDS-20
Parking



GDS-21
Minibus Rank



GDS-22
Toll Plaza Ahead

REGULATIONS
Road Traffic and Transport Act 22 of 1999
Road Traffic and Transport Regulations, 2001

D. Freeway Direction Signs:

GA1 : Pre-advance exit direction sign:

COLOURS:

Border & arrow: White retro-reflective
 Legend: White retro-reflective
 Route number: Yellow retro-reflective
 Background: Blue retro-reflective
 Interchange exit number: Black semi-matt on white retro-reflective

GA1

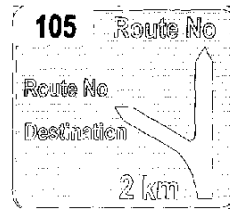

GA2 : Advance exit direction sign:

COLOURS:

Border & arrow: White retro-reflective
 Legend: White retro-reflective
 Route number: Yellow retro-reflective
 Background: Blue retro-reflective
 Interchange exit number & location: white retro-reflective

GA2

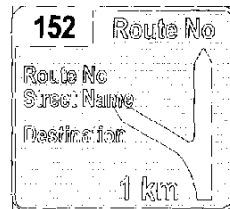

GA2/3 : Supplementary exit direction sign:

COLOURS:

Border & arrow: White retro-reflective
 Legend: White retro-reflective
 Route number: Yellow retro-reflective
 Background: Blue retro-reflective
 Interchange exit number & location: white retro-reflective

GA2/3

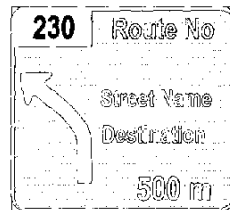

Temporary sign number TGA2/3.

GA3 : Exit direction sign:

COLOURS:

Border & arrow: White retro-reflective
 Legend: White retro-reflective
 Route number: Yellow retro-reflective
 Background: Blue retro-reflective
 Interchange exit number & location: white retro-reflective

GA3

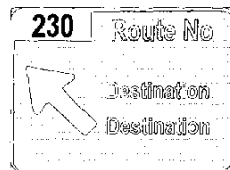

REGULATIONS
Road Traffic and Transport Act 22 of 1999
Road Traffic and Transport Regulations, 2001

GA4 : Gore exit direction sign:

COLOURS:

- Border & arrow: White retro-reflective
- Legend: Black semi-matt
- Background: Blue retro-reflective
- Chevron: Red retro-reflective on white retro-reflective

Temporary sign number TGA4.

GA4

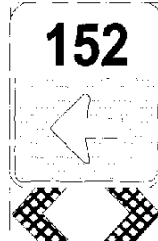

GA5 : Advance off-ramp terminal direction sign:

COLOURS:

- Border & arrow: White retro-reflective
- Legend: White retro-reflective
- Route number: Yellow retro-reflective
- Background: Green retro-reflective
- Street name: Black semi-matt on white retro-reflective

GA5

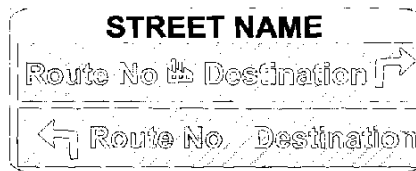

GA6 : Off-ramp terminal direction sign:

COLOURS:

- Border & arrow: White retro-reflective
- Legend: White retro-reflective
- Route number: Yellow retro-reflective
- Background: Green retro-reflective
- Chevron: Red retro-reflective on white retro-reflective

GA6



GA7 : Confirmation sign:

COLOURS:

- Border: White retro-reflective
- Legend: White retro-reflective
- Route number: Yellow retro-reflective
- Background: Blue retro-reflective

GA7



GA8 : Exit sequence sign:

COLOURS:

- Border & legend: White retro-reflective
- Background: Blue retro-reflective
- Interchange exit numbers & location: Black semi-matt on white retro-reflective

GA8

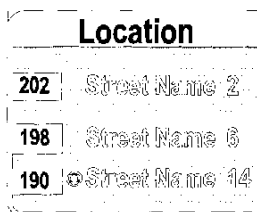

REGULATIONS
Road Traffic and Transport Act 22 of 1999
Road Traffic and Transport Regulations, 2001

GA9 : C-D Road advance exit direction sign:

GA9

COLOURS:

Border & legend: White retro-reflective
 Route number: Yellow retro-reflective
 Background: Blue retro-reflective



GA10 : Road exit direction sign:

GA10

COLOURS:

Border & legend: White retro-reflective
 Route number: Yellow retro-reflective
 Background: Blue retro-reflective



GB1 : Cross-road advance direction sign:

GB1

COLOURS:

Border & arrow: White retro-reflective
 Legend: White retro-reflective
 Route number: Yellow retro-reflective
 Background: Green or blue & green retro-reflective
 Interchange exit number & local or regional authority name: Black semi-matt on white retro-reflective

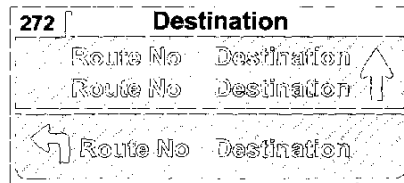

GB2 : Near side on-ramp direction sign:

GB2

COLOURS:

Border & arrow: White retro-reflective
 Legend: White retro-reflective
 Route number: Yellow retro-reflective
 Background: Blue or green retro-reflective



GB3 : Advance far-side on-ramp direction sign:

GB3

COLOURS:

Border & arrow: White retro-reflective
 Legend: White retro-reflective
 Route number: Yellow retro-reflective
 Background: Blue or green retro-reflective

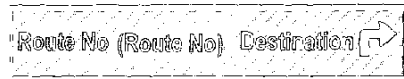

REGULATIONS
Road Traffic and Transport Act 22 of 1999
Road Traffic and Transport Regulations, 2001

GB4 : Far-side on-ramp direction sign:

COLOURS:

Border & arrow: White retro-reflective
 Legend: White retro-reflective
 Route number: Yellow retro-reflective
 Background: Blue or green retro-reflective

GB4



GC1 : Overhead pre-advance exit direction sign:

COLOURS:

Border & arrow: White retro-reflective
 Legend: White retro-reflective
 Route number: Yellow retro-reflective
 Background: Blue retro-reflective
 Interchange exit number: Black semi-matt on white retro-reflective

GC1

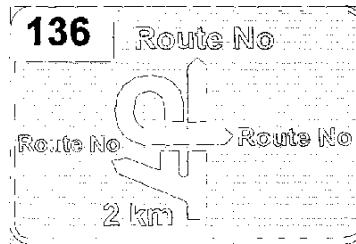

GC2D : Overhead advance exit direction sign:

COLOURS:

Border & arrow: White retro-reflective
 Legend: White retro-reflective
 Route number: Yellow retro-reflective
 Background: Blue retro-reflective
 Interchange exit number & location: white retro-reflective

GC2D

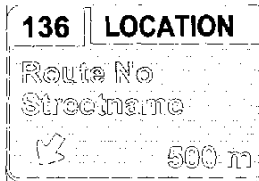

GC3D : Overhead through or straight-on direction sign:

COLOURS:

Border & arrow: White retro-reflective
 Legend: White retro-reflective
 Route number: Yellow retro-reflective
 Background: Blue retro-reflective

GC3D

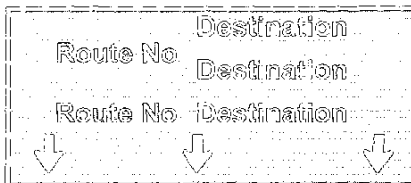

GC4D : Overhead exit direction sign:

COLOURS:

Border & arrow: White retro-reflective
 Legend: White retro-reflective
 Route number: Yellow retro-reflective
 Background: Blue retro-reflective
 Interchange exit number & destination: white retro-reflective

GC4D

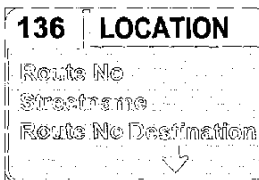

REGULATIONS
Road Traffic and Transport Act 22 of 1999
Road Traffic and Transport Regulations, 2001

GC2U : Overhead advance exit direction sign:

GC2U

COLOURS:

Border & arrow: White retro-reflective
 Legend: White retro-reflective
 Route number: Yellow retro-reflective
 Background: Blue retro-reflective
 Interchange exit number & location: white retro-reflective

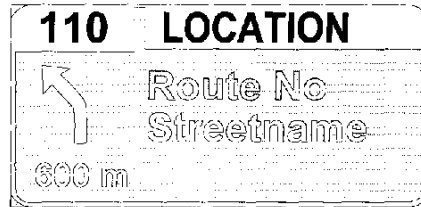

GC3U : Overhead supplementary exit/ through direction sign:

GC3U

COLOURS:

Border, symbol & arrow: White retro reflective
 Legend: White retro-reflective
 Route number: Yellow retro-reflective
 Background: Blue retro-reflective
 Interchange exit number: Black semi-matt on white retro-reflective

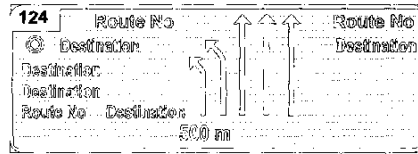

GC4U : Overhead exit direction sign:

GC4U

COLOURS:

Border & arrow: White retro-reflective
 Legend: White retro-reflective
 Route number: Yellow retro-reflective
 Background: Blue retro-reflective
 Interchange exit number & location: white retro-reflective

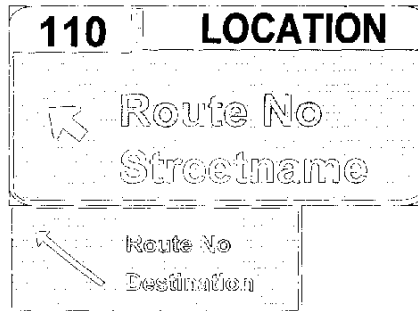

GCSU : Overhead advance off-ramp direction sign:

GCSU

COLOURS:

Border & arrow: White retro-reflective
 Legend: White retro-reflective
 Route number: Yellow retro-reflective
 Background: Blue retro-reflective
 Interchange exit number: Black semi-matt on white retro-reflective



REGULATIONS
Road Traffic and Transport Act 22 of 1999
Road Traffic and Transport Regulations, 2001

GC6U : Overhead through direction sign:

GC6U

COLOURS:

Border & arrow: White retro-reflective
 Legend: White retro-reflective
 Route number: Yellow retro-reflective
 Background: Blue retro-reflective



GC7U : Overhead collector-distributor through direction sign:

GC7U

COLOURS:

Border & arrow: White retro-reflective
 Legend: White retro-reflective
 Route number: Yellow retro-reflective
 Background: Blue retro-reflective



GC8U : C-D Road advance exit through sign:

GC8U

COLOURS:

Border & arrow: White retro-reflective
 Legend: White retro-reflective
 Route number: Yellow retro-reflective
 Background: Blue retro-reflective



REGULATIONS
Road Traffic and Transport Act 22 of 1999
Road Traffic and Transport Regulations, 2001

E. Tourism Direction Signs:

GF1 : Freeway advance exit sign:

COLOURS:

- Border & legend: White retro-reflective
- Symbol: White or coloured retro-reflective
- Background: Brown semi-matt or retro-reflective
- Interchange exit number: Black semi-matt on white retro-reflective

Temporary sign number TGF1.

GF1



GF2 : Advance turn sign:

COLOURS:

- Border & arrow: White retro-reflective
- Legend: White retro-reflective
- Symbol: White or coloured retro-reflective
- Background: Brown semi-matt or retro-reflective

GF2



GF3 : Final turn sign:

COLOURS:

- Border & arrow: White retro-reflective
- Legend: White retro-reflective
- Symbol: White or coloured retro-reflective
- Background: Brown semi-matt or retro-reflective

GF3



GF4 : Gore exit sign:

COLOURS:

- Border & arrow: White retro-reflective
- Background: Brown retro-reflective
- Chevron: Red retro-reflective on white retro-reflective
- Interchange exit number: Black semi-matt on white retro-reflective

GF4

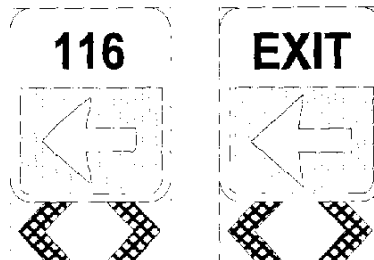

REGULATIONS
Road Traffic and Transport Act 22 of 1999
Road Traffic and Transport Regulations, 2001

GF5 : Layby advance sign:

COLOURS:

Border & legend: White retro-reflective
 Symbol: White or coloured retro-reflective
 Background: Brown semi-matt or retro-reflective

GF5

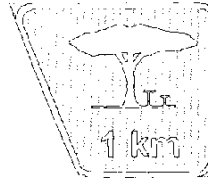

GF6 : Layby turn-in sign:

COLOURS:

Border & arrow: White retro-reflective
 Symbol: White retro-reflective
 Background: Brown semi-matt or retro-reflective

GF6

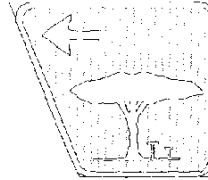

GF7 : Confirmation sign:

COLOURS:

Border: White retro-reflective
 Legend & symbol: White retro-reflective
 Background: Brown semi-matt or retro-reflective

GF7

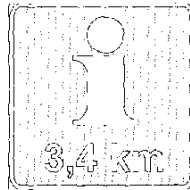

GF8 : Service exit sequence sign:

COLOURS:

Border & legend: White retro-reflective
 Symbol: White or coloured retro-reflective
 Background: Brown semi-matt or retro-reflective
 Interchange exit numbers & place name: white back-ground

GF8

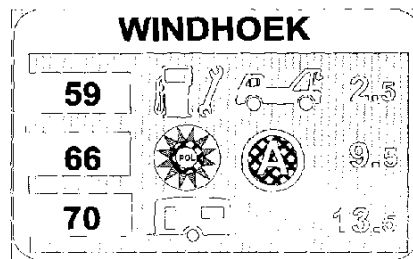

REGULATIONS
Road Traffic and Transport Act 22 of 1999
Road Traffic and Transport Regulations, 2001

GF9 : Rest and service sequence sign:

COLOURS:

Border & legend: White retro-reflective
 Symbol: White retro-reflective
 Route number: Yellow retro-reflective
 Background: Brown semi-matt or retro-reflective
 Interchange exit number: Black semi-matt on a white background

GF9

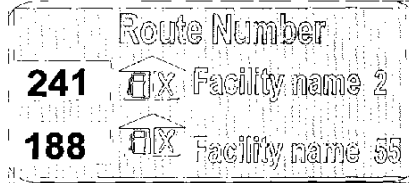

GF10 : Rest and service "totem" sign:

COLOURS:

Border: White retro-reflective
 Symbol: White retro-reflective
 Background: Brown, green or blue retro-reflective
 Route number : Yellow reflective

GF10

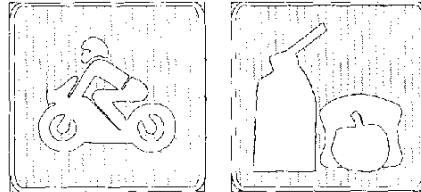

GF11 : Roadside emergency service spacing sign:

COLOURS:

Border & legend: White retro-reflective
 Symbol: Appropriate symbol colours retro-reflective
 Background: Brown retro-reflective

GF11



GF12 : Advance roadside emergency service sign:

COLOURS:

Border & legend: White retro-reflective
 Symbol: Appropriate symbol colours retro-reflective
 Background: Brown retro-reflective

GF12



REGULATIONS
Road Traffic and Transport Act 22 of 1999
Road Traffic and Transport Regulations, 2001

GF13 : Roadside emergency service turn-in sign:

COLOURS:

Border & arrow: White retro-reflective
Legend: White retro-reflective
Symbol: Appropriate symbol colours retro-reflective
Background: Brown retro-reflective

GF13



GF14 : Final roadside emergency service sign:

COLOURS:

Border & legend: White retro-reflective
Symbol: Appropriate symbol colours retro-reflective
Background: Brown retro-reflective

GF14

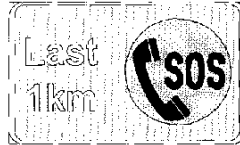

Temporary sign number TGF14.

GF15 : Parking sign:

COLOURS:

Border & symbol: White retro-reflective
Background: Brown semi-matt or retro-reflective

GF15

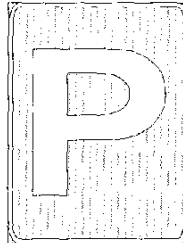

GF16 : Tourist information sign:

COLOURS:

Border & symbol: White retro-reflective
Background: Brown semi-matt or retro-reflective

GF16

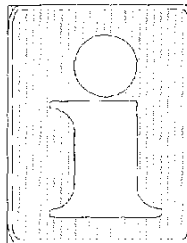

REGULATIONS
Road Traffic and Transport Act 22 of 1999
Road Traffic and Transport Regulations, 2001

GF17 : Part-time attraction sign:

COLOURS:

Border & symbol: White retro-reflective
Background: Brown semi-matt or retro-reflective

Temporary sign number TGF17.

GF17

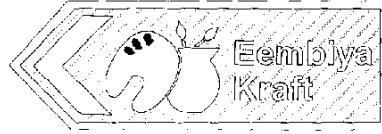

GF18 : Emergency service sign:

COLOURS:

Border: White retro-reflective
Symbols: Appropriate symbol colours retro-reflective
Background: Brown semi-matt or retro-reflective

Temporary sign number TGF18.

GF18

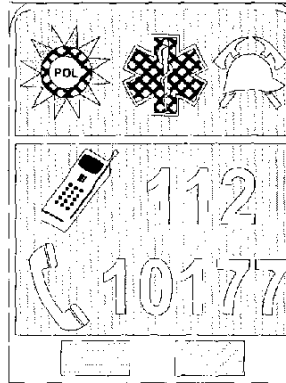

REGULATIONS
Road Traffic and Transport Act 22 of 1999
Road Traffic and Transport Regulations, 2001

National Park attractions:



GFS A1
Generic
National Park



GFS A1-2
National Parks
(Nam)

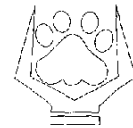

GFS A2
Generic
Regional Parks

GFS A1 to GFS A2

Resort Attractions:



GFS A3
Generic
Resorts



GFS A3-1
Country Clubs
(Golf)



GFS A3-2
Hot Springs



GFS A3-3
Inland water

GFS A3 to GFS A3-5



GFS A3-4
Seaside/Beach



GFS A3-5
Berg/Mountain

Scenic attractions:



GFS A4
Generic Scenic



GFS A4-1
Nature
Reserve

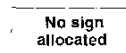

GFS A4-2
Natural
Heritage Site



GFS A4-3
Botanical Gardens

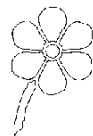

GFS A4-4
Gardens/Flowers

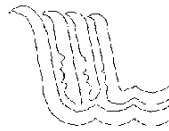

GFS A4-5
Waterfall



GFS A4-6
Lake or Dam
(No watersport)



GFS A4-7
Caves

GFS A4 to GFS A4-11

REGULATIONS
Road Traffic and Transport Act 22 of 1999
Road Traffic and Transport Regulations, 2001



GFS A4-8
View Point



GFS A4-9
Forest (Natural)

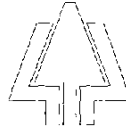

GFS A4-10
State Forest



GFS A4-11
Mountain/Berg

Sport venues:

GFS A5-1 to GFS A5-8

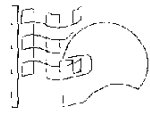

GFS A5-1
Motor Racing
Track



GFS A5-2
Golf Course



GFS A5-3
Hourse Race
Course



GFS A5-4
Equestrian
Events



GFS A5-5
Fishing



GFS A5-6
Cricket Field



GFS A5-7
Swimmingpool



GFS A5-8
Sport Stadium

Wildlife Attractions:

GFS A6 to GFS A6-8



GFS A6
Generic-
Wildlife



GFS A6-1
Conservancy
Area



GFS A6-2
Game Reserve



GFS A6-3
Bird Park/
Sanctuary



GFS A6-4
Zoo



GFS A6-5
Snake Park



GFS A6-6
Crocodile Park



GFS A6-7
Rhino Park



GFS A6-8
Lion Park

REGULATIONS
Road Traffic and Transport Act 22 of 1999
Road Traffic and Transport Regulations, 2001

Historical Attractions:



**GFS A7
Generic
Historical**



**GFS A7-1
National
Monument (Nam)**



**GFS A7-2
Museum**

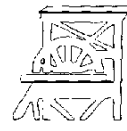

**GFS A7-3
Historic Mine**

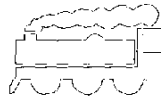

**GFS A7-4
Historic
Railway Station**

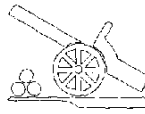

**GFS A7-5
Historic
Battlefield**



**GFS A7-6
Historic
Cemetery**



**GFS A7-7
Geological
Site**

GFS A7-1 to GFS A7-7

Coastal Attractions:

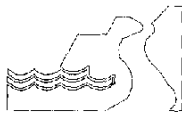

**GFS A8
Generic
Coastal**

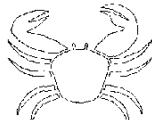

**GFS A8-1
Marine
Reserve**

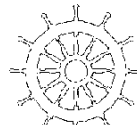

**GFS A8-2
Maritime
Museum**



**GFS A8-3
Aquarium**



**GFS A8-4
Whales**

GFS A8 to GFS A8-12



**GFS A8-5
Dolphins**

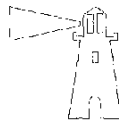

**GFS A8-6
Lighthouse**



**GFS A8-7
Dockyard**

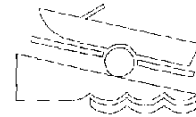

**GFS A8-8
Boat Launch**



**GFS A8-9
Fishing**



**GFS A8-10
Crayfish**



**GFS A8-11
Oceanarium**



**GFS A8-12
Beach**

REGULATIONS
Road Traffic and Transport Act 22 of 1999
Road Traffic and Transport Regulations, 2001

Arts & crafts attractions:



**GFS A9
Generic Arts
& Crafts**



**GFS A9-1
Painting &
Drawing**



**GFS A9-2
Pottery**

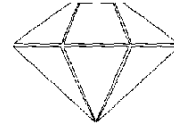

**GFS A9-3
Jewelry**

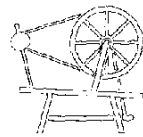

**GFS A9-4
Weaving
& Knitting**



**GFS A9-5
Leatherwork**

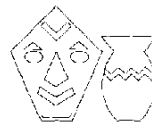

**GFS A9-6
African Arts
& Crafts**

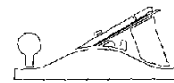

**GFS A9-7
Woodwork**



**GFS A9-8
Metalwork**

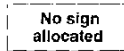

**GFS A9-9
Sculpting**

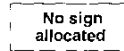

**GFS A9-10
Glass &
Ceramics**

GFS A9 to GFS A9-10

Cultural attractions:



**GFS A10
Generic Cultural**



**GFS A10-1
Theatre**



**GFS A10-2
Amphitheatre**

GFS A10 to GFS A10-3

REGULATIONS
Road Traffic and Transport Act 22 of 1999
Road Traffic and Transport Regulations, 2001

Adventure attractions:

GFS A11 to GFS A11-7

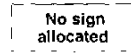

GFS A11
Generic
Adventure



GFS A11-1
Hiking Trail

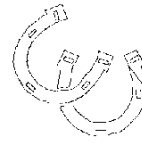

GFS A11-2
Horse
Trail



GFS A11-3
4x4 Trail

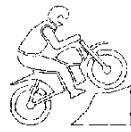

GFS A11-4
Bike Trail



GFS A11-5
River Rafting

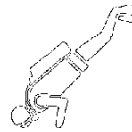

GFS A11-6
Scuba Diving

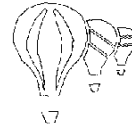

GFS A11-7
Ballooning

Farming parks attraction:

GFS A12 to GFS A12-9



GFS A12
Generic
Farming



GFS A12-1
Wine Cellar



GFS A12-2
**Wine Route/
 Estate**



GFS A12-3
Showground

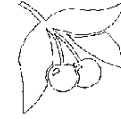

GFS A12-4
Cherry Farm



GFS A12-5
Ostrich Farm
and Riding



GFS A12-6
Ostrich Farm



GFS A12-7
Fish Farm



GFS A12-8
Roadside
Stall



GFS A12-9
Butterfly
Farm

General attraction sign:

GFS A13 to GFS A13-1



GFS A13
Generic
General Attractions



GFS A13-1
Animal
Theme Park

REGULATIONS
Road Traffic and Transport Act 22 of 1999
Road Traffic and Transport Regulations, 2001

Service symbols : Emergency services:

GFS B1-1 to GFS B1-10

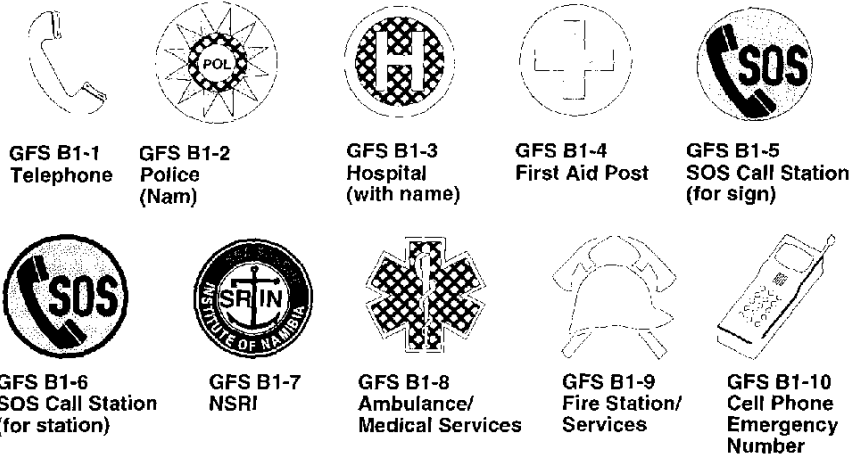

Light vehicle services:

GFS B2-1 to GFS B2-4

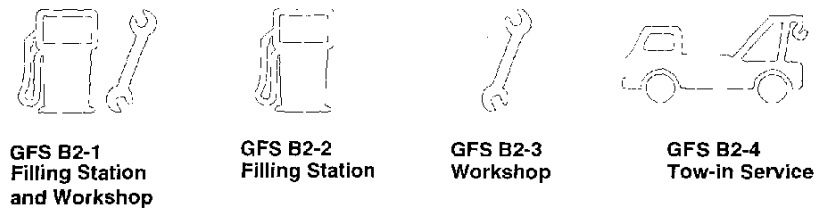

Truck services:

GFS B3-1



**GFS B3-1
Truck Rest & Service Area**

Food services:

GFS B4-1 to B4-4

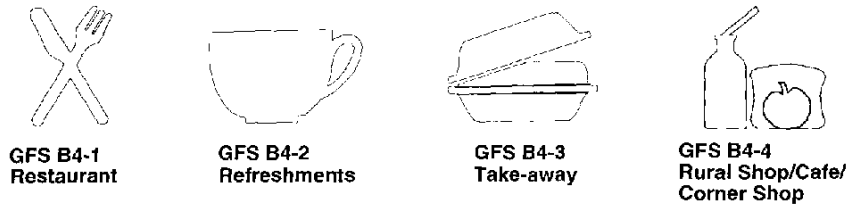

REGULATIONS
Road Traffic and Transport Act 22 of 1999
Road Traffic and Transport Regulations, 2001

General services:

GFS B5-1 to GFS B5-12



GFS B5-1
Parking Area
(Free Parking)



GFS B5-2
Toilets

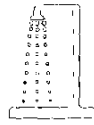

GFS B5-3
Shower

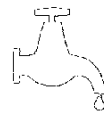

GFS B5-4
Drinking Water



GFS B5-5
Fireplace

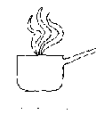

GFS B5-6
Cooking
Facilities



GFS B5-7
Picnic Area



GFS B5-8
Tourist
Information



GFS B5-9
Facility for
Disabled
Persons



GFS B5-10
Roadside Stall/
Curio Shop

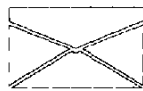

GFS B5-11
Generic Post Office



GFS B5-12
Shop

Rest and service areas:

GFS B6-1 to GFS B6-3



GFS B6-1
Rest Area (Class 1)



GFS B6-2
Rest Area (Class 2)



GFS B6-3
Service Area (Class 3)

Vehicle class:

GFS B7-1 to GFS B7-6



GFS B7-1
Motor cars



GFS B7-2
Caravans



GFS B7-3
Buses

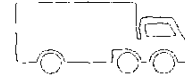

GFS B7-4
Trucks

REGULATIONS
Road Traffic and Transport Act 22 of 1999
Road Traffic and Transport Regulations, 2001



GFS B7-5
Delivery vehicles



GFS B7-6
Motor cycles

Accommodation symbols:

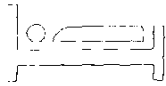

GFS C1-1
Accommodation
(Incl. Hotels, Inns, etc.)



GFS C1-2
Chalets



GFS C1-3
Caravan Site

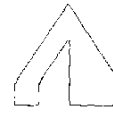

GFS C1-4
Camp Site



GFS C1-5
Generic Guest
House



GFS C1-6
Bed & Breakfast



GFS C1-7
Rooms (Bed
Only)



GFS C1-8
Youth Hostel/
Centre/Camp

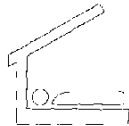

GFS C1-9
Trail Shelter



GFS C1-10
Guest Farm

GFS C1-1 to GFS C1-10

Rest and service area : "Totem" sign symbols:

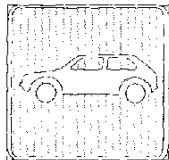

GFSD1-1
Motor cars

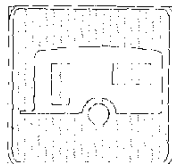

GFSD1-2
Caravans

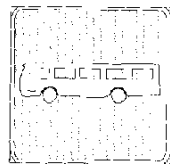

GFSD1-3
Buses

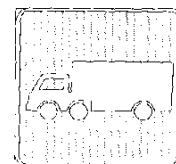

GFSD1-4
Trucks

GFSD1-1 to GFSD1-28

REGULATIONS
Road Traffic and Transport Act 22 of 1999
Road Traffic and Transport Regulations, 2001

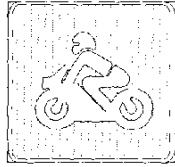

GFS D1-5
Motorcycle



GFS D1-6
Take-away

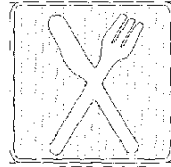

GFS D1-7
Restaurant



GFS D1-8
Refreshments



GFS D1-9
Shop



GFS D1-10
**Facility for handi-
capped people**

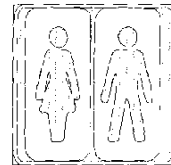

GFS D1-11
Toilets

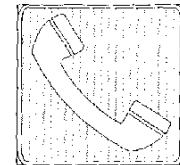

GFS D1-12
Telephone

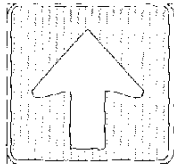

GFS D1-13
Straight-on Arrow

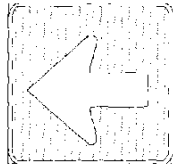

GFS D1-14
Left/Right Arrow

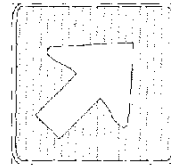

GFS D1-15
**Diagonal Left/
Right Arrow**

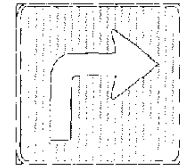

GFS D1-16
**Advance Left/
Right Arrow**



GFS D1-17
**Exit (Route
Number)**

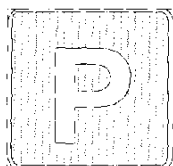

GFS D1-18
Parking

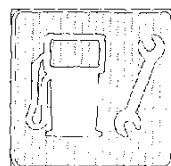

GFS D1-19
**Filling Station
and workshop**

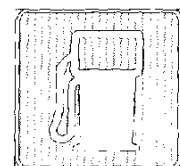

GFS D1-20
Filling station

REGULATIONS
Road Traffic and Transport Act 22 of 1999
Road Traffic and Transport Regulations, 2001

No. 2503

Government Gazette 30 March 2001

301

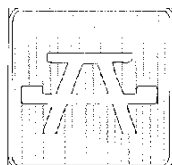

GFS D1-21
Picnic Area

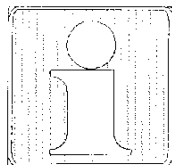

GFS D1-22
Tourist
Information

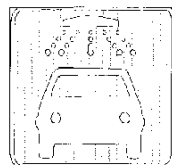

GFS D1-23
Motorcar Wash

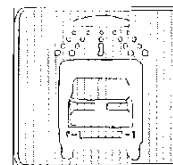

GFS D1-24
Truck Wash

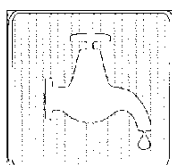

GFS D1-25
Drinking Water

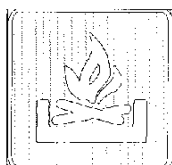

GFS D1-26
Fireplace

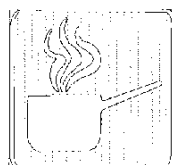

GFS D1-27
Cooking facilities

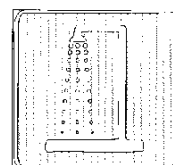

GFS D1-28
Shower

REGULATIONS
Road Traffic and Transport Act 22 of 1999
Road Traffic and Transport Regulations, 2001

F. Local Direction Signs

GDL1 : Advance local direction sign:

COLOURS:

Border: Blue retro-reflective
Arrow, legend & symbol: Black semi-matt
Background: White semi-matt or retro-reflective

GDL1



Temporary sign number TGDL1.

GDL2 :Local direction sign:

COLOURS:

Border: Blue retro-reflective
Arrow, legend & symbol: Black semi-matt
Background: White semi-matt or retro-reflective

GDL2



Temporary sign number TGDL2.

GDL3 :Local fingerboard sign:

COLOURS:

Border: Blue retro-reflective
Arrow, legend & symbol: Black semi-matt
Background: White semi-matt or retro-reflective

GDL3











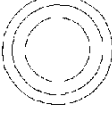
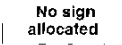
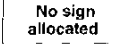
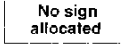

Temporary sign number TGDI.3.

REGULATIONS
Road Traffic and Transport Act 22 of 1999
Road Traffic and Transport Regulations, 2001

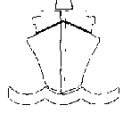
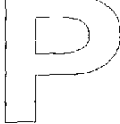

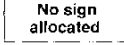



Major traffic generators - High use level:

GDLS A1-1 to GDLS A1-14

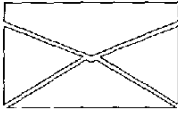
				
GDLS-A1-1 Central Business Centre	GDLS-A1-2 University	GDLS-A1-3 Technikon	GDLS-A1-4 Education College	GDLS-A1-5 Shopping Centre
				
GDLS-A1-6 Railway Station	GDLS-A1-7 Airport	GDLS-A1-8 Bus Terminus	GDLS-A1-9 Minibus Rank	GDLS-A1-10 Harbour
				
GDLS-A1-11 Parking	GDLS-A1-12 Parking Garage	GDLS-A1-13 Modal Transfer Station	GDLS-A1-14 Mine	

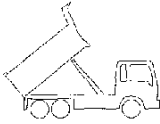
Major traffic generators - Regular use level

GDLS A2-1 to GDLS A2-14

				
GDLS-A2-1 Information Centre/Layby	GDLS-A2-2 Post Office	GDLS-A2-4 Industrial Area	GDLS-A2-5 Park 'n Ride	
				
GDLS-A2-6 Waste Disposal Site	GDLS-A2-7 Produce Market	GDLS-A2-11 Power Station	GDLS-A2-13 Library	GDLS-A2-14 Swimming Pool

REGULATIONS
Road Traffic and Transport Act 22 of 1999
Road Traffic and Transport Regulations, 2001

Minor traffic generator - irregular use level

GDLS A3-1 to GDLS A3-11

No signs allocated

GDLS-A3-1 Cemetery	GDLS-A3-2 Garden refuse	GDLS-A3-3 Places of worship	GDLS-A3-4 Broadcast station	GDLS-A3-5 Drive-in theatre	GDLS-A3-6 Nursery (Plants)
-----------------------	-------------------------------	-----------------------------------	-----------------------------------	----------------------------------	----------------------------------

No signs allocated

GDLS-A3-7 Sports club	GDLS-A3-8 Traffic Department	GDLS-A3-9 Electricity Department	GDLS-A3-10 Testing Grounds	GDLS-A3-11 Licence Offices
--------------------------	------------------------------------	--	----------------------------------	----------------------------------

Emergency services:

GDLS A4-1 to GDLS A4-6

No sign
allocated

No sign
allocated



No sign
allocated

GDLS A4-1
Clinic

GDLS A4-2
Medical Centre

GDLS A4-3
Fire Station

GDLS A4-4
Community
Centre



No sign
allocated

GDLS A4-5
Heliport

GDLS A4-6
SPCA

Minor traffic generator - Low level use

SPCA sign:

GDLS A4-6

No sign allocated

REGULATIONS
Road Traffic and Transport Act 22 of 1999
Road Traffic and Transport Regulations, 2001

G. Diagrammatic Signs:

GS100 Series : Traffic movement affected by obstruction sign:

COLOURS:

Border & block: Red retro-reflective
Arrow: Black semi-matt
Background: White retro-reflective

Temporary sign numbers TGS101 to TGS158.

GS100 Series

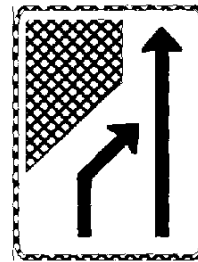

GS200 Series : Additional lane sign:

COLOURS:

Border: Red retro-reflective
Arrow: Black semi-matt
Background: White retro-reflective

Temporary sign numbers TGS201 to TGS214.

GS200 Series

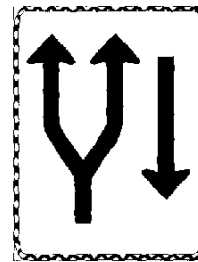

GS300 Series : Lane use control by regulatory sign:

COLOURS:

Border: Red retro-reflective
Arrow: Black semi-matt
Background: White retro-reflective
Regulatory sign: Standard permanent colours

Temporary sign numbers TGS301 to TGS311.

GS300 Series

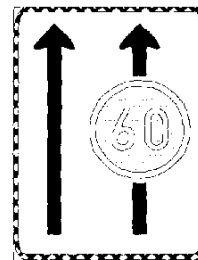

REGULATIONS
Road Traffic and Transport Act 22 of 1999
Road Traffic and Transport Regulations, 2001

GS401 to GS406 : Lanes merge sign:

COLOURS:

Border: Red retro-reflective
Arrow: Black semi-matt
Background: White retro-reflective

Temporary sign numbers TGS401 to TGS406.

GS401 to GS406

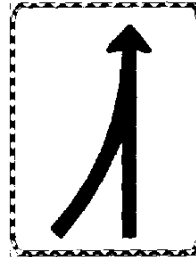

GS451 to GS454 : Lanes converge sign:

COLOURS:

Border: Red retro-reflective
Arrow: Black semi-matt
Background: White retro-reflective

Temporary sign numbers TGS451 to TGS454.

GS451 to GS454

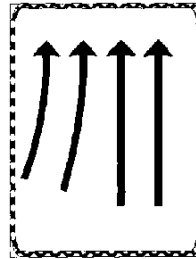

GS501 : Arrestor bed pre-advance exit sign:

COLOURS:

Border: Red retro-reflective
Symbol: Red retro-reflective on white retro-reflective
Arrow & legend: Black semi-matt
Background: White retro-reflective

Temporary sign number TGS501.

GS501

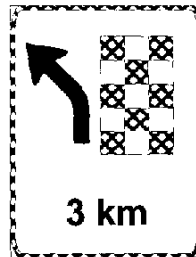

GS502 : Arrestor bed advance exit sign:

COLOURS:

Border: Red retro-reflective
Symbol: Red retro-reflective on white retro-reflective and black semi-matt
Legend: Black semi-matt
Background: White retro-reflective

Temporary sign number TGS502.

GS502

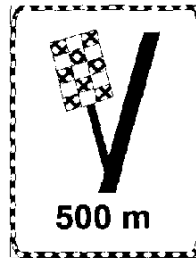

REGULATIONS
Road Traffic and Transport Act 22 of 1999
Road Traffic and Transport Regulations, 2001

GS503 : Arrestor bed exit sign:

COLOURS:

- Border: Red retro-reflective
- Symbol: Red retro-reflective on white retro-reflective
- Arrow: Black semi-matt
- Background: White retro-reflective

Temporary sign number TGS503.

GS503

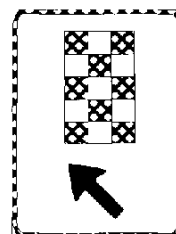

GS504 : Arrestor bed gore exit sign:

COLOURS:

- Border: Red retro-reflective
- Symbol: Red retro-reflective on white retro-reflective
- Arrow: Black semi-matt
- Background: White retro-reflective

Temporary sign number TGS504.

GS504

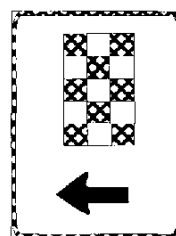

GS505 : Engage lower gear sign:

COLOURS:

- Border & arrow: Red retro-reflective
- Symbol: Black semi-matt
- Background: White retro-reflective

Temporary sign number TGS505.

GS505

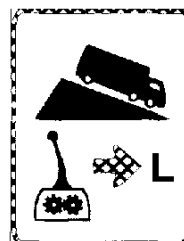

GS601 : Overhead arrestor bed advance exit sign:

COLOURS:

- Border: Red retro-reflective
- Symbol: Red retro-reflective on white retro-reflective
- Arrow & legend: Black semi-matt
- Background: White retro-reflective

Temporary sign number TGS601.

GS601

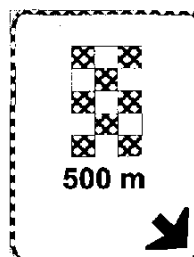

REGULATIONS
Road Traffic and Transport Act 22 of 1999
Road Traffic and Transport Regulations, 2001

GS602 : Overhead arrestor bed exit sign:

GS602

COLOURS:

Border: Red retro-reflective
Symbol: Red retro-reflective on white retro-reflective
Arrow: Black semi-matt
Background: White retro-reflective

Temporary sign number TGS602.

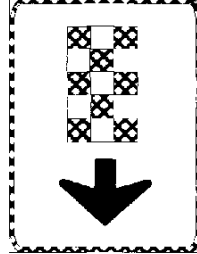

GS603 to GS611 : Overhead lane use control by regulation sign:

GS603 to GS611

COLOURS:

Border: Red retro-reflective
Arrow: Black semi-matt
Background: White retro-reflective
Regulatory sign: Standard permanent colours

Temporary sign numbers TGS603 to TGS611.

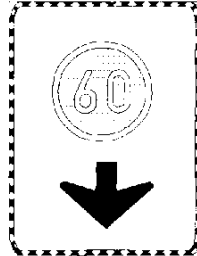

GS701 to GS706 : Public transport sign:

GS701 to GS706

COLOURS:

Border: Red retro-reflective
Arrow: Red retro-reflective
Symbols: Black semi-matt
Background: White retro-reflective

Temporary sign numbers TGS701 to TGS706.

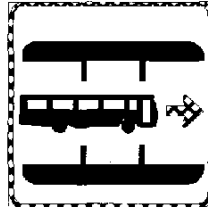

GS801 to GS820 : Grade lane layout sign:

GS801 to GS820

COLOURS:

Border: Red retro-reflective
Arrow: Black semi-matt
Background: White retro-reflective

Temporary sign numbers TGS801 to TGS820.

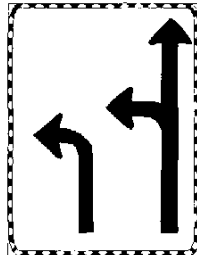

REGULATIONS
Road Traffic and Transport Act 22 of 1999
Road Traffic and Transport Regulations, 2001

GS901 and GS902 : Junction with warning sign:

COLOURS:

Border: Red retro-reflective
Arrow: Black semi-matt
Warning sign: Standard colours
Background: White retro-reflective

Temporary sign number TGS901-TGS902.

GS901 and GS902

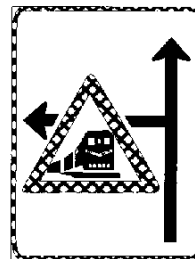

GSS1 and GSS2 : Diagrammatic sign symbols:

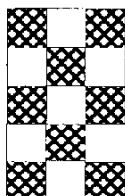

GSS-1
Arrestor Bed



GSS-2
Change to Lower Gear

REGULATIONS
Road Traffic and Transport Act 22 of 1999
Road Traffic and Transport Regulations, 2001

(iv) Information Signs:

IN1 to IN3 : Countdown signs:

COLOURS:

- Border: White retro-reflective
- Symbol: White retro-reflective
- Background: Blue, green or brown retro-reflective

Temporary sign numbers TIN1, TIN2 and TIN3.
 Indicates to the driver of a vehicle that a high-speed exit is approximately 100 metres, 200 metres and 300 metres, respectively, ahead.

IN1 and IN2

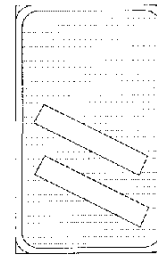
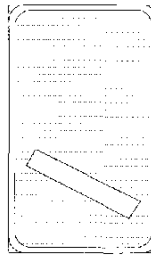

IN3

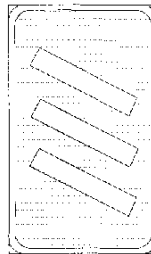

IN4 to IN6 : Cul-de-sac sign:

COLOURS:

- Border: White retro-reflective
- Symbol: Red & white retro-reflective
- Background: Green semi-matt or retro-reflective

Temporary sign numbers TIN4, TIN5 and TIN6.
 Indicates to the driver of a vehicle that the roadway beyond the sign, in the case of sign IN4 or to the left or right of the sign in the case of signs IN5 and IN6 is not a through road.

IN4 and IN5

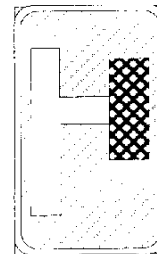
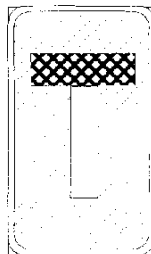

IN6

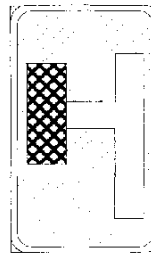

REGULATIONS
Road Traffic and Transport Act 22 of 1999
Road Traffic and Transport Regulations, 2001

IN7 : Right of way sign:

COLOURS:

Border: Black semi-matt
 Symbol: Yellow retro-reflective
 Background: White retro-reflective

Indicates to the driver of a vehicle that traffic on the roadway on which he or she is travelling has right of way at the junction ahead.

IN7

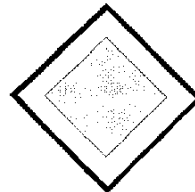

IN8 : No sign allocated

IN9 and IN10 : Park and ride sign:

COLOURS:

Border: White retro-reflective
 Symbol: White retro-reflective
 Background: Green semi-matt or retro-reflective

Temporary sign numbers TIN9 and TIN10.
 Indicates to the driver of a vehicle the existence of a park and ride terminus.

IN9 and IN10

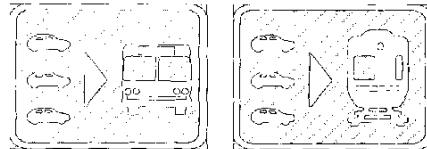

IN11.1 to IN11.5, IN11.501 to IN11.583, IN11.6:
Supplementary plate signs:

COLOURS:

Border: Black semi-matt
 Symbol/legend: Black semi-matt
 Background: White retro-reflective or semi-matt

Temporary sign numbers TIN11.1 to TIN11.5, TIN11.501 to TIN11.583, TIN11.6
 Indicates to the driver of a vehicle supplementary information related to the principal message of a regulatory, warning or diagrammatic guidance sign.

IN11.1 and IN11.2



IN11.3 and IN11.4

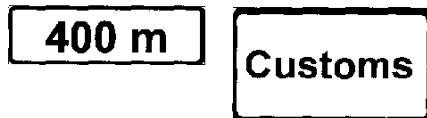

IN11.5 and IN11.501



IN11.583



REGULATIONS
Road Traffic and Transport Act 22 of 1999
Road Traffic and Transport Regulations, 2001

IN12 : Information centre sign:

COLOURS:

Border: White retro-reflective
 Symbol: White retro-reflective
 Background: Green semi-matt or retro-reflective

Temporary sign number TIN12.
 Indicates to the driver of a vehicle the location of an information office, kiosk or board.

IN12

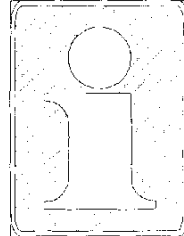

TIN13 : Road experiment sign:

COLOURS:

Border: Black semi-matt
 Legend: Black semi-matt
 Background: Yellow retro-reflective

Indicates to the driver of a vehicle that a temporary experiment or research activity is being conducted on a section of the public road.

TIN13



IN14 : Co-ordinated traffic signals sign:

COLOURS:

Border: White retro-reflective
 Symbol: White & green retro-reflective & grey semi-matt
 Background: Green semi-matt or retro-reflective

Temporary sign number TIN14.
 Indicates to the driver of a vehicle that the traffic signals on the section of the public road beyond the sign are co-ordinated at the average speed indicated on the sign.

IN14

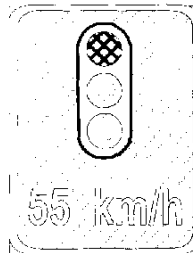

IN15 : Multi-phase traffic signals sign:

COLOURS:

Border: White retro-reflective
 Symbol: White retro-reflective
 Background: Green semi-matt or retro-reflective

Temporary sign number TIN15.
 Indicates to the driver of a vehicle that the traffic signals at the junction about to be entered have more than two phases.

IN15

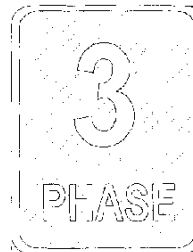

REGULATIONS
Road Traffic and Transport Act 22 of 1999
Road Traffic and Transport Regulations, 2001

IN16 : Bus stop ahead sign:

COLOURS:

- Border: White retro-reflective
- Symbol: White retro-reflective
- Background: Green semi-matt or retro-reflective

Temporary sign number TIN16.
 Indicates to the driver of a vehicle that a bus stop is the indicated distance ahead.

IN16

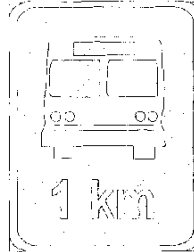

IN17 to IN19 : Modal transfer signs:

COLOURS:

- Border: White retro-reflective
- Symbol: White retro-reflective
- Background: Green semi-matt or retro-reflective

Temporary sign numbers TIN17, TIN18 and TIN19.
 Indicates to the driver of a vehicle that there is a transport interchange point ahead where he or she may change his or her mode of transport.

IN17 and IN18

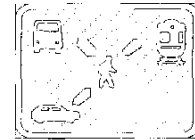
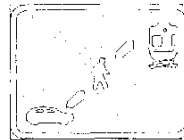

IN19



TIN20 to TIN23 : Cul-de-sac signs:

COLOURS:

- Border: Black semi-matt
- Symbol: Black and red semi-matt
- Background: Yellow semi-matt or retro-reflective

Indicates to the driver that the roadway as indicated on the sign is not a through road.

TIN20 and TIN21

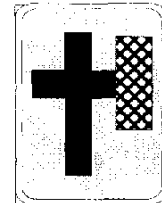
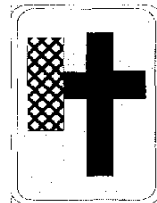

TIN22 and TIN23

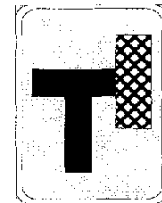
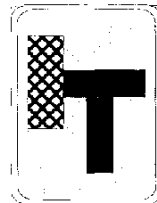

REGULATIONS
Road Traffic and Transport Act 22 of 1999
Road Traffic and Transport Regulations, 2001

IN24 and IN25 : Toll tariff board - standard and reduced sign:

COLOURS:

- Border: White retro-reflective
- Symbol: White retro-reflective
- Background: Green semi-matt or retro-reflective

Temporary sign number TIN24 and TIN25.
 Indicates to the driver of a vehicle what the toll fees are for the toll plaza ahead.

IN24 and IN25

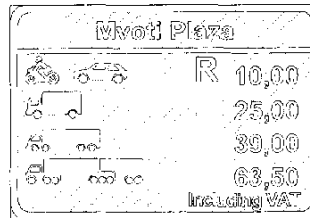
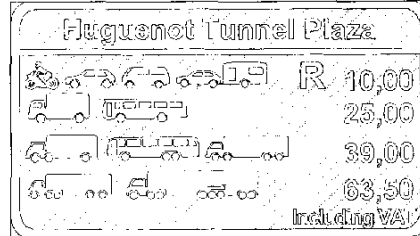

IN26 : Text message sign:

COLOURS:

- Border: White retro-reflective
- Symbol: White retro-reflective
- Background: Green semi-matt or retro-reflective

Temporary sign number TIN26.
 Provides additional information for road users.

IN26



IN27 : Autotoll sign:

COLOURS:

- Border: White retro-reflective
- Symbol: White retro-reflective
- Background: Green semi-matt or retro-reflective

Temporary sign number TIN27.
 Indicates to the driver of a vehicle that an autotoll is operational.

IN27

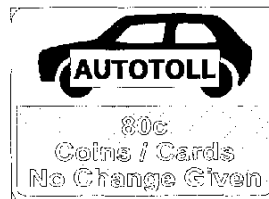

REGULATIONS
Road Traffic and Transport Act 22 of 1999
Road Traffic and Transport Regulations, 2001

CLASS II : ROAD MARKINGS

(i) Regulatory Markings

Regulatory markings are classified as follows:

- A. Transverse regulatory markings
- B. Longitudinal regulatory markings

A. Transverse Regulatory Markings:

RTM1 : Stop line marking:

COLOUR:

White

Indicates to the driver of a vehicle that he or she shall stop his or her vehicle immediately behind such line and such line has the significance assigned to stop signs R1, R1.1, R1.3 or R1.4: Provided that a road sign or road signal indicating that the driver may proceed has preference over such marking: Provided further that the word marking "STOP" shall be omitted at traffic signal controlled interseptions and pedestrian crossings.

RTM1

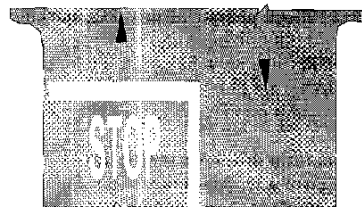

RTM2 : Yield line marking:

COLOUR:

White

Indicates to the driver of a vehicle -

- (a) the point where he or she shall yield right of way to all traffic on the public road which is joined by the public road on which he or she is travelling and such marking has the significance assigned to yield sign R2, R2.1 or R2.2; or
- (b) that he or she shall yield right of way to all rail traffic on the railway line which is crossed by the public road on which he or she is travelling.

RTM2

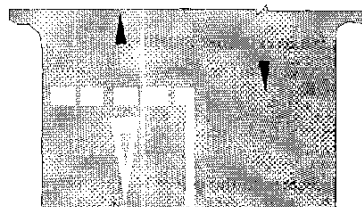

REGULATIONS
Road Traffic and Transport Act 22 of 1999
Road Traffic and Transport Regulations, 2001

RTM3 : Pedestrian crossing lines marking:

COLOUR:

White

Indicates to the driver of a vehicle that he or she shall yield right of way, slow down or stop if need to be so to yield to a pedestrian crossing the roadway within the pedestrian crossing when the pedestrian is upon that half of the roadway upon which the vehicle is travelling, or when the pedestrian is approaching so closely from the opposite half of the roadway as to be in danger.

RTM3

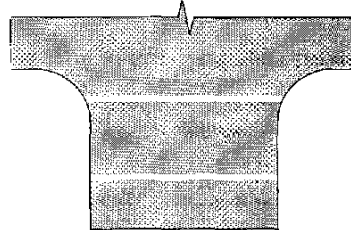

RTM4 : Block pedestrian crossing markings:

COLOUR:

White

Indicates to the driver of a vehicle that he or she shall yield right of way, slow down or stop if need to be so to yield to a pedestrian crossing the roadway within the pedestrian crossing when the pedestrian is upon that half of the roadway upon which the vehicle is travelling, or when the pedestrian is approaching so closely from the opposite half of the roadway as to be in danger.

RTM4

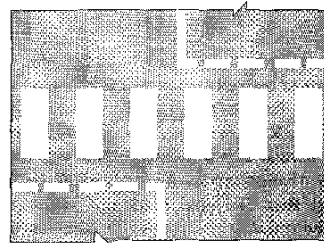

B. Longitudinal Regulatory Markings:

RM1 : No overtaking marking:

COLOUR:

White

- (a) Indicates to the driver of a vehicle that he or she shall not drive his or her vehicle in such a manner that the vehicle or any part thereof, crosses such no overtaking marking, or is upon that part of the roadway to the right of such no overtaking marking when -
- (i) the no overtaking marking is used in lieu of a dividing line marking; or
 - (ii) the no overtaking line marking is used together with a dividing line marking, and is to the left of the dividing line marking,
- except to -
- (aa) gain direct access to land on the opposite side of the no overtaking marking;
 - (bb) gain direct access from land to a portion

RM1



REGULATIONS
Road Traffic and Transport Act 22 of 1999
Road Traffic and Transport Regulations, 2001

- of the public road; or
- (cc) pass any stationary obstruction in the roadway, unless it is safe to do so.
- (b) The no overtaking marking may only be used between lanes of traffic travelling in opposite directions.
- (c) The no overtaking marking applies to the driver of a vehicle travelling -
 - (aa) on either side of such marking where such marking is used alone; or
 - (bb) to the left of such marking where such marking is used in conjunction with dividing line WM3.

RM2 : No crossing marking:

COLOUR:

White

- (a) Indicates to the driver of a vehicle that he or she shall not drive his or her vehicle in such a manner that such vehicle or any part of such vehicle -
 - (i) crosses such marking; or
 - (ii) is on the right side of such marking.
- (b) The no crossing marking may only be used between lanes of traffic travelling in opposite directions.

RM2

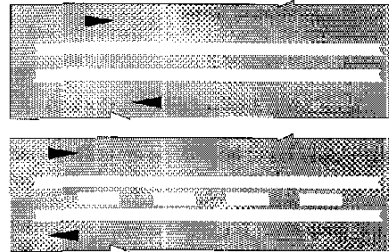

RM3 : Channelizing line marking:

COLOUR:

White

- (a) Indicates to the driver of a vehicle that he or she shall not drive his or her vehicle in such a manner that such vehicle or any part of such vehicle crosses such marking.
- (b) The channelizing line marking may only be used between lanes of traffic travelling in the same direction.

RM3



RM4.1 : Left edge line marking:

COLOUR:

Yellow

Indicates to the driver of a vehicle the left edge of the roadway and he or she shall not drive to the left of such marking or cross such marking.

RM4.1

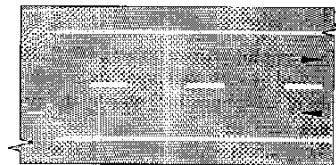

REGULATIONS
Road Traffic and Transport Act 22 of 1999
Road Traffic and Transport Regulations, 2001

RM4.2 : Right edge line marking:

COLOUR:

White

Indicates to the driver of a vehicle the right edge of the roadway and that he or she shall not drive such vehicle to the right of such marking or cross such marking.

RM4.2

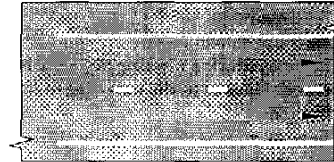

RM5 : Painted island marking:

COLOURS:

Border: White on the right of the direction of travel or yellow on the left of the direction of travel

Diagonal

Lines: Yellow

Indicates to the driver of a vehicle that he or she shall not -

- (a) drive his or her vehicle in such a manner that such vehicle or any part of such vehicle crosses such marking; or
- (b) stop his or her vehicle so that such vehicle or any part of such vehicle is upon such marking.

RM5

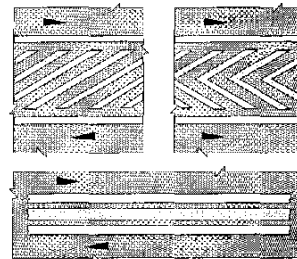

RM6 : Parking bay marking:

COLOUR:

White

Indicates to the driver of a vehicle that if he or she parks his or her vehicle he or she shall do so within the demarcated parking bay and that no part of such vehicle may be on any side walk.

RM6

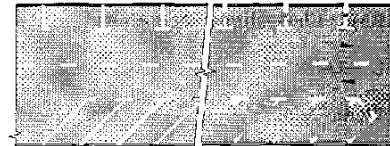

RM7 : Exclusive parking bay marking:

COLOUR:

Yellow

(a) Indicates to the driver of a vehicle that the area marked by such marking is exclusively for the use of vehicles as indicated by the symbol in such marking.

- (b) The symbols which may be used are:
 - (i) A - ambulances;
 - (ii) B - buses;
 - (iii) L - loading zones;

RM7

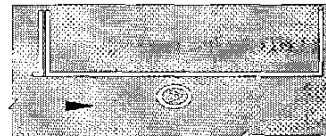

REGULATIONS
Road Traffic and Transport Act 22 of 1999
Road Traffic and Transport Regulations, 2001

- (iv) T - taxis;
 - (v) F - fire fighting vehicles;
 - (vi) P - Police;
 - (vii) R - rickshaws;
 - (viii) CD - diplomatic vehicles;
 - (ix) SOS - SOS-telephone;
 - (x) D - Defence Force;
 - (xi) MB - minibuses.
- (c) Where an area is demarcated -
- (i) as a loading zone, no vehicle, other than -
 - (aa) a goods vehicle; and
 - (bb) a motor cycle designed or adapted to convey goods on a public road,
 may use the loading zone for the loading or unloading of goods and only for a period which is reasonably necessary for the loading or unloading of the goods;
 - (ii) for a minibus, midibus or bus, no vehicle, other than a minibus, midibus or bus while it is operating on a fixed route may use such demarcated area;
 - (iii) for any other vehicle, no vehicle, other than a vehicle of the class for which the area has been demarcated, may park or stop in the demarcated area; or
 - (iv) for an SOS-telephone, the driver of a vehicle shall not stop or park his or her vehicle in such area except in an emergency.

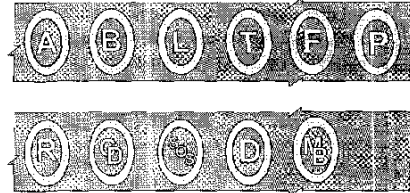

RM8 : Mandatory direction arrow markings:

COLOUR:

Yellow

Indicates to the driver of a vehicle that he or she shall proceed only in the direction indicated by such arrow.

RM8

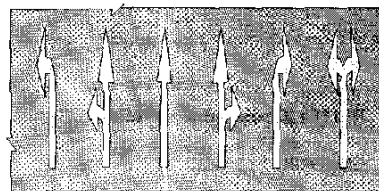

RM9 : Exclusive lane line marking:

COLOUR:

Yellow

Indicates to the driver of a vehicle that he or she shall

RM9

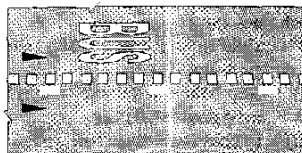

REGULATIONS
Road Traffic and Transport Act 22 of 1999
Road Traffic and Transport Regulations, 2001

not drive, park or stop a vehicle in a lane marked by such marking unless it is a vehicle of the class indicated by the symbol marking referred to in road marking RM17 or a reservation sign.

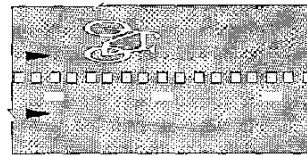
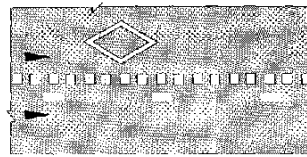
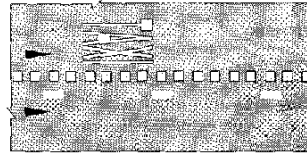

RM10 : Box junction marking:

COLOUR:

Yellow

Indicates to the driver of a vehicle that he or she shall not enter the box area in a junction if he or she is not able to cross such area due to stationary vehicles blocking his or her way, but a vehicle turning to the left or to the right may enter such junction.

RM10

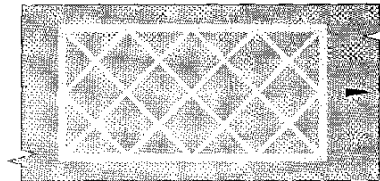

RM11 : Zig-zag zone marking:

COLOUR:

White

Indicates to the driver of a vehicle -

- (a) that he or she shall not bring his or her vehicle to a stop within the zig-zag zone marked by such lines except to -
 - (i) yield right of way to pedestrians on the crossing;
 - (ii) stop behind a vehicle complying with subparagraph (i); or
 - (iii) to obey a traffic signal; and
- (b) that he or she shall not cross such marking.

RM11

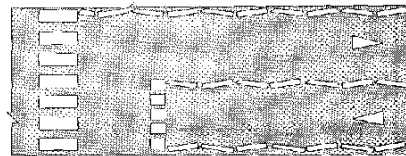

REGULATIONS
Road Traffic and Transport Act 22 of 1999
Road Traffic and Transport Regulations, 2001

RM12 : No stopping line marking:

COLOUR:

Red

Indicates to the driver of a vehicle -

- (a) not to stop his or her vehicle adjacent to such line; or
- (b) where such line is a broken line not to stop his or her vehicle adjacent to such line during the time period indicated by an accompanying road sign.

RM12

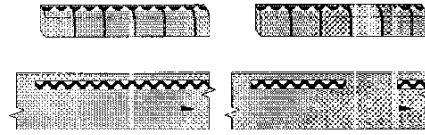

RM13 : No parking line marking:

COLOUR:

Yellow

Indicates to the driver of a vehicle on a public road in an urban area -

- (a) not to park his or her vehicle adjacent to such line; or
- (b) where such line is a broken line, not to park his or her vehicle adjacent to such line during the time period indicated by an accompanying road sign.

RM13

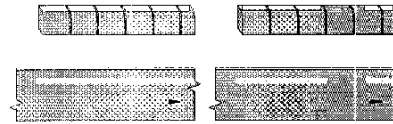

RM14 : No motor cycles marking:

COLOUR:

Yellow

Indicates to the driver of a motor cycle that he or she shall not proceed beyond such marking.

RM14



RM15 : Mini-circle marking:

COLOUR:

Dot and arrows: Yellow
 Border: White

Indicates to the driver of a vehicle approaching a traffic circle that he or she shall yield right of way to any vehicle which will cross any yield line at such junction before him or her and which, in the normal course of events, will cross the path of such driver's vehicle and that he or she shall travel in a clockwise direction in such circle and as far as possible avoiding driving over the mini-circle marking.

RM15

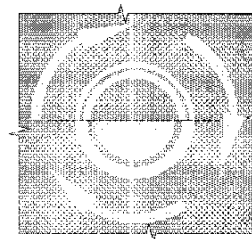

REGULATIONS
Road Traffic and Transport Act 22 of 1999
Road Traffic and Transport Regulations, 2001

RM16 : Parking reservation for a person with a physical disability:

COLOUR:

Yellow

Indicates to the driver of a vehicle that the parking bay is reserved for a vehicle transporting a person with a physical disability.

RM16

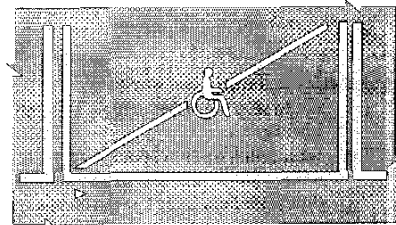

RM17 : Exclusive use lane symbol markings:

COLOUR:

Yellow

- (a) Indicates to the driver of a vehicle that the lane marked by exclusive use lane marking, RM9, is for the use of vehicles as indicated by the lane symbol marking or as indicated by a reservation sign.
- (b) Symbols which may be used with an exclusive use lane marking are:
 - (i) RM17.1 - bicycle;
 - (ii) RM17.2 - bus;
 - (iii) RM17.3 - tram;
 - (iv) RM17.4 - high occupancy vehicle.

RM17

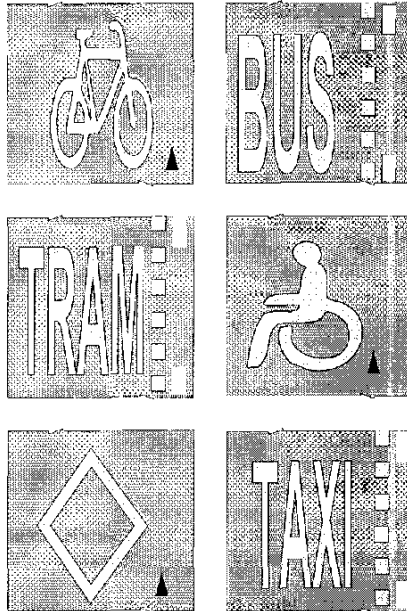

REGULATIONS
Road Traffic and Transport Act 22 of 1999
Road Traffic and Transport Regulations, 2001

(ii) **Warning Markings:**

WM1 : Railway crossing marking:

COLOUR:

White

Warns a road user of a railway crossing ahead.

WM1

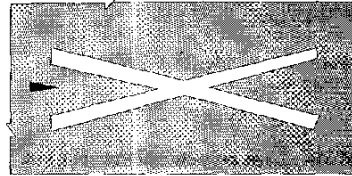

WM2 : Continuity line marking:

COLOUR:

White

Warns a road user by indicating the outer limits of a continuous portion of the roadway, that those portions of the roadway outside such marking do not continue straight on.

WM2

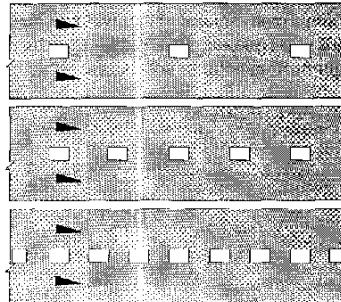

WM3 : Dividing lines:

COLOUR:

White

Warns a road user that vehicles on the other side of such marking are travelling in the opposite direction.

WM3

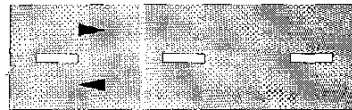

WM4 : Reversible lane lines:

COLOUR:

White

Warns a road user that the lane so marked may be used by traffic in opposite directions during different specific periods of the day or night.

WM4

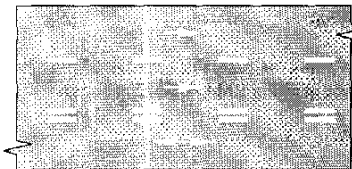

REGULATIONS
Road Traffic and Transport Act 22 of 1999
Road Traffic and Transport Regulations, 2001

WM5 : Yield sign ahead marking:

COLOUR:

White

Warns a road user of a yield sign R2 or marking RTM2 ahead.

WM5

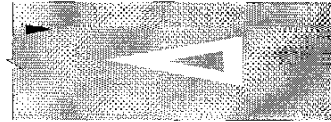

WM6 : Lane reduction arrow marking:

COLOUR:

White

Warns a road user that a lane on a multi-lane roadway ends some distance ahead either from the left or the right or from both the left and the right.

WM6

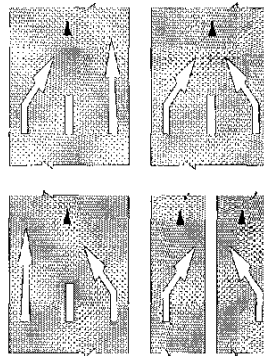

WM7 : Mandatory direction arrow ahead marking:

COLOUR:

White

Warns a road user that a mandatory direction arrow RM8 is ahead.

WM7

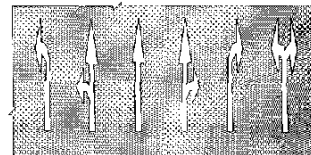

WM8 : No overtaking or no crossing line ahead marking:

COLOUR:

White

Warns a road user that a no overtaking or no crossing line marking RM1 or RM2 is ahead.

WM8

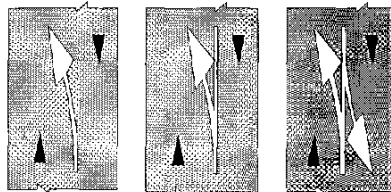

REGULATIONS
Road Traffic and Transport Act 22 of 1999
Road Traffic and Transport Regulations, 2001

WM9.1 : Arrestor bed ahead marking:

COLOUR:

Red & white

Warns a road user that an arrestor bed is ahead.

WM9.1

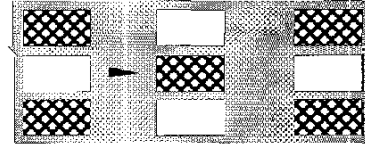

WM9.2 : Escape road ahead marking:

COLOUR:

Red & white

Warns a road user of an escape road ahead.

WM9.2

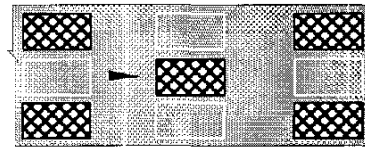

WM10 : Speed hump marking:

COLOUR:

White

Warns a road user of a speed hump in the roadway.

WM10

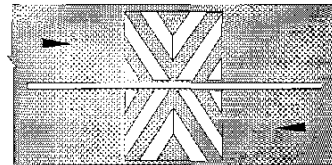

WM11 : End of exclusive use lane arrows marking:

COLOUR:

White

Warns a road user that an exclusive use lane has ended.

WM11

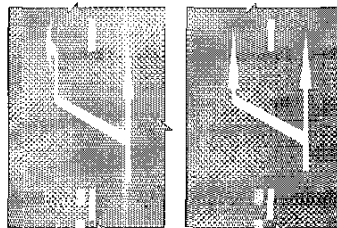

REGULATIONS
Road Traffic and Transport Act 22 of 1999
Road Traffic and Transport Regulations, 2001

(iii) **Guidance Markings**

GM1 : Lane line marking:

COLOUR:

White

Demarcates traffic lanes for road users, travelling on a roadway or portion of roadway in the same direction.

GM1

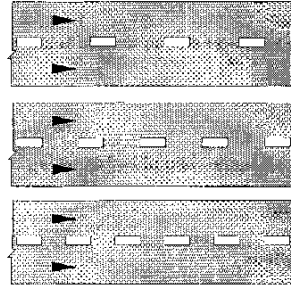

GM2 : Guide line marking:

COLOUR:

White

Gives additional guidance -

- (a) to a road user when turning to the left or right in a junction;
- (b) to a road user when a shift in lane alignment occurs across a junction; or
- (c) to pedestrians when the position of a pedestrian crossing is not obvious in a junction.

GM2

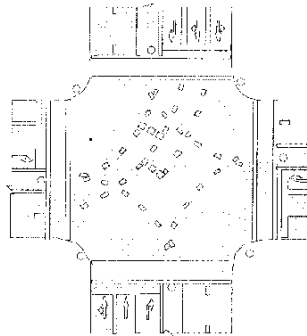

GM3 : Furcation arrow marking:

COLOUR:

White

Indicates to a road user an increase in the number of lanes ahead.

GM3

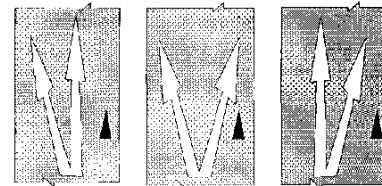

REGULATIONS
Road Traffic and Transport Act 22 of 1999
Road Traffic and Transport Regulations, 2001

GM4 : Information arrow marking:

COLOUR:

White

Indicates to a road user the direction of travel on a particular lane or roadway.

GM4

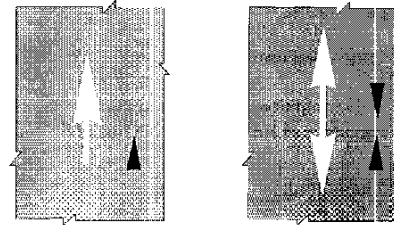

GM5 : Bicycle crossing guideline marking:

COLOUR:

White

Indicates to a road user the section of a roadway to be used by cyclists to cross such roadway.

GM5

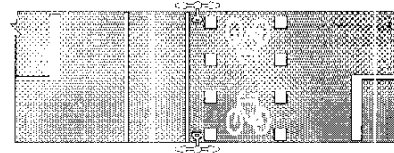

GM6 : Symbol road marking:

COLOUR:

White

Gives additional guidance to a road user.

GM6

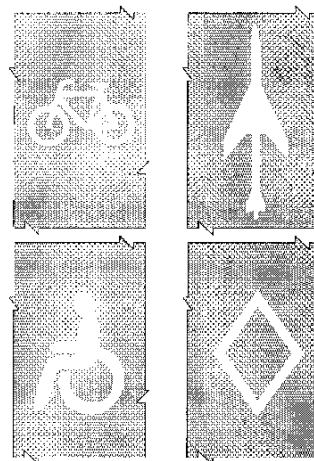

GM7 : Word markings:

COLOUR:

White

Gives additional guidance to a road user.

GM7

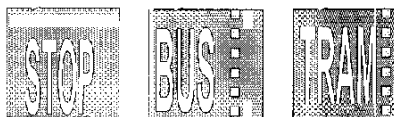

REGULATIONS
Road Traffic and Transport Act 22 of 1999
Road Traffic and Transport Regulations, 2001

GM8 : Kerbface markings:

COLOUR:

Black and white

Gives additional guidance to a road user regarding the presence of kerbs on the kerb line of the roadway.

GM8



REGULATIONS
Road Traffic and Transport Act 22 of 1999
Road Traffic and Transport Regulations, 2001

CLASS III: ROAD SIGNALS

(i) Regulatory Signals

(1) Regulatory signals are classified as follows:

A Traffic signals -

- (i) Vehicular light signals;
- (ii) Pedestrian light signals; and
- (li) Pedal cyclist light signals;

[This subparagraph should be labelled “(iii)” instead of “(li)”.]

B Red flashing signal;

C Overhead lane direction control signals; and

D Other regulatory signals

A. Traffic signals: S1 - S15

(1) (a) A traffic signal may only display the following light signals and be arranged to conform to one of the standard traffic signals as shown in paragraph (2):

(i) vehicular light signals -

- (aa) a steady red disc light signal;
- (bb) a flashing red disc light signal;
- (cc) a steady red bus disc light signal;
- (dd) a steady red tram disc light signal;
- (ee) a steady red arrow light signal;
- (ff) a flashing red arrow light signal;
- (gg) a steady yellow disc light signal;
- (hh) a flashing yellow disc light signal;
- (ii) a steady yellow bus disc light signal;
- (jj) a steady yellow tram disc light signal;
- (kk) a steady yellow arrow light signal;
- (ll) a steady green disc light signal;

REGULATIONS
Road Traffic and Transport Act 22 of 1999
Road Traffic and Transport Regulations, 2001

- (mm) a steady green bus disc light signal;
- (nn) a steady green tram disc light signal;
- (oo) a flashing green bus disc light signal;
- (pp) a flashing green tram disc light signal;
- (qq) a steady green arrow light signal; or
- (rr) a flashing green arrow light signal; or
- (ii) pedestrian and pedal cyclist light signals
 - (aa) a steady red man light signal;
 - (bb) a flashing red man light signal or flashing green man light signal; or
 - (cc) a steady green man light signal;
 - (dd) a steady red pedal cycle light signal;
 - (ee) a flashing red pedal cycle light signal, or flashing green pedal cycle light signal; or
 - (ff) a steady green pedal cycle signal.
- (b) Where there is no pedestrian light signal to control the movement of pedestrians at a junction, a pedestrian shall comply with the vehicular light signals installed at such junction and the provisions of roadmarking RTM3 applies.

[The verb “applies” should be “apply” to accord with the subject “provisions”.]

- (c) The significance of the light signals referred to in subregulation (1) are -
 - (i) for vehicular light signals -
 - (aa) **A steady red disc light signal**
 Indicates to the driver of a vehicle that he or she shall stop his or her vehicle behind the stop line RTM1 and that he or she shall remain stationary until a green light signal is displayed, and it is safe to proceed, and in the event that a pedestrian light signal is not provided, to indicate to a pedestrian that he or she shall not cross the roadway until a green light signal is displayed and it is safe to do so;
 - (bb) **A flashing red disc light signal**
 Indicates to the driver of a vehicle that he or she shall act as for a 4-way stop sign R 1.4 and shall yield right of way to all pedestrians crossing his or her path and to indicate to a pedestrian that he or she may cross the roadway if it is safe to do so;
 - (cc) **A steady red bus light signal**

REGULATIONS
Road Traffic and Transport Act 22 of 1999
Road Traffic and Transport Regulations, 2001

Indicates to the driver of a bus that he or she shall stop his or her bus behind the stop line RTM1 and that he or she shall remain stationary until a green bus light signal is displayed, and it is safe to proceed, and in the event that a pedestrian light signal is not provided, indicates to a pedestrian that he or she shall not cross the roadway until a green light signal is displayed and it is safe to do so;

(dd) **A steady red tram light signal**

Indicates to the driver of a tram that he or she shall stop his or her tram behind the stop line RTM 1 and that he or she shall remain stationary until a green tram light signal is displayed, and it is safe to proceed, and in the event that a pedestrian light signal is not provided, indicates to a pedestrian that he or she shall not cross the roadway until a green light signal is displayed and it is safe to do so;

(ee) **A steady red arrow light signal**

Indicates to the driver of a vehicle that he or she shall stop his or her vehicle behind the stop line if he or she intends turning in the direction indicated by the red signal and that he or she shall remain stationary until a green aspect is displayed that allows movement in the direction of the arrow and it is safe to proceed;

(ff) **A flashing red arrow light signal**

Indicates to the driver of a vehicle that he or she shall stop his vehicle behind the stop line RTM1 and if he or she intends to turn left at the junction he or she may proceed to turn left, although the red disc light signal is displayed, and he or she shall yield right of way to all vehicles and pedestrians for whom a green disc light signal is displayed;

(gg) **A steady yellow disc light signal**

Indicates to the driver of a vehicle that he or she shall stop his or her vehicle behind the stop line RTM1 and that he or she shall remain stationary until a green light signal is displayed, and it is safe to proceed, but if he or she is so close to a stop line RTM1 when a yellow light signal is displayed that he or she cannot stop safely, he or she may proceed with caution against such yellow light signal and if a pedestrian light signal is not provided or illuminated indicates to a pedestrian that he or she shall not cross a roadway until a green light signal is displayed and it is safe to do so;

(hh) **A flashing yellow disc light signal**

Indicates to the driver of a vehicle that he or she shall proceed with caution and shall yield right of way to all pedestrians crossing his path and indicates to a pedestrian that he or she may cross the roadway if it is safe to do so;

(ii) **A steady yellow bus disc light signal**

Indicates to the driver of a bus that he or she shall stop his or her vehicle behind the stop line RTM1 and that he or she shall remain stationary until a green light signal is displayed, and it is safe to proceed, but if he or she is so close to a stop line RTM1 when a yellow light signal is displayed that he or she cannot stop safely, he or

REGULATIONS
Road Traffic and Transport Act 22 of 1999
Road Traffic and Transport Regulations, 2001

she may proceed with caution against such yellow light signal, and in the event that a pedestrian light signal is not provided indicates to a pedestrian that he or she shall not cross a roadway until a green light signal is displayed and it is safe to do so;

(jj) A steady yellow tram disc light signal

Indicates to the driver of a tram that he or she shall stop his or her vehicle behind the stop line RTM1 and that he or she shall remain stationary until a green light signal is displayed, and it is safe to proceed, but if he or she is so close to a stop line RTM1 when a yellow light signal is displayed that he or she cannot stop safely, he or she may proceed with caution against such yellow light signal and in the event that a pedestrian light signal is not provided indicates to a pedestrian that he or she shall not cross a roadway until a green light signal is displayed and it is safe to do so;

(kk) A steady yellow arrow light signal

Indicates to the driver of a vehicle that he or she shall stop his or her vehicle behind the stop line RTM1 if he or she intends turning in the direction indicated by the yellow arrow light signal and that he or she shall remain stationary until a green light signal allowing the movement is displayed, and it is safe to proceed, but if he or she is so close to stop line RTM1 when a yellow arrow light signal is displayed that he or she cannot stop safely then he or she may proceed with caution against such yellow arrow light signal, and in the event that a pedestrian light signal is not provided, indicates to a pedestrian that he or she shall not cross a roadway until a green light signal is displayed and it is safe to do so;

(ll) A steady green disc light signal

Indicates to the driver of a vehicle that he or she may proceed through a junction, or turn to the left or right in such junction, subject to any restricting road traffic sign, but shall yield right of way to other vehicular traffic and to pedestrians lawfully within the junction, or at a pedestrian crossing, at the time such light signal is displayed, and if a pedestrian light signal is not provided or illuminated, indicates to a pedestrian that he or she may cross the junction within the pedestrian crossing markings RTM3 or RTM4, as appropriate;

(mm) A steady green bus disc light signal

Indicates to the driver of a bus that he or she may proceed through a junction, or turn to the left or right in such junction, subject to any restricting road traffic sign, but shall yield right of way to other vehicular traffic and to pedestrians lawfully within the junction, or at a pedestrian crossing, at the time such light signal is displayed, and in the event that a pedestrian light signal is not provided, to indicate to a pedestrian that he or she may cross the junction within the pedestrian crossing markings RTM3 or RTM4, as appropriate;

(nn) A steady green tram disc light signal

Indicates to the driver of a tram that he or she may proceed through a junction, or turn to the left or right in such junction, subject to any restricting road traffic sign, but shall yield right of way to other

REGULATIONS
Road Traffic and Transport Act 22 of 1999
Road Traffic and Transport Regulations, 2001

vehicular traffic and to pedestrians lawfully within the junction, or at a pedestrian crossing, at the time such light signal is displayed, and in the event that a pedestrian light signal is not provided, to indicate to a pedestrian that he or she may cross the junction within the pedestrian crossing markings RTM3 or RTM4, as appropriate;

- (oo) **A flashing green bus disc light signal**
Indicates to the driver of a bus that he or she may proceed and his or her movements are unopposed by other traffic facing a red light signal;
 - (pp) **A flashing green tram disc light signal**
Indicates to the driver of a tram that he or she may proceed and his or her movements are unopposed by other traffic facing a red light signal;
 - (qq) **A steady green arrow light signal**
Indicates to the driver of a vehicle that he or she may proceed only in the direction indicated by the arrow, subject to any restricting road traffic sign, but shall yield right of way to other vehicular traffic and to pedestrians lawfully within the junction, or at a pedestrian crossing, at the time such light signal is displayed and if a pedestrian light signal is not provided or illuminated, to indicate to a pedestrian that he or she may cross
 - (rr) **A flashing green arrow light signal**
Indicates to the driver of a vehicle that he or she may proceed only in the direction indicated by the arrow and that such arrow light signal shall only be displayed together with a steady red disc light signal for any vehicular traffic which will be in conflict with such direction of movement; and
- (ii) for pedestrian and pedal cyclist light signals
- (aa) **A steady red man light signal**
Indicates to a pedestrian that he or she shall not cross the roadway until the green man light signal is displayed;
 - (bb) **A flashing red man light and flashing green man light signal**
Indicates to a pedestrian -
 - (aaa) who has not yet commenced crossing the roadway that he or she shall not cross the roadway until the steady green man light signal is displayed, or
 - (bbb) who is within a pedestrian crossing that the red man light signal will follow shortly;
 - (cc) **A steady green man light signal**
Indicates to a pedestrian that he or she may cross the junction within the pedestrian crossing markings RTM3 or RTM4, as appropriate, and that the driver of a vehicle shall yield right of way to a pedestrian crossing such junction.
 - (dd) **A steady red pedal cycle light signal**
Indicates to a pedal cyclist that he or she shall not cross the roadway until the steady green bicycle light signal is displayed;

REGULATIONS
Road Traffic and Transport Act 22 of 1999
Road Traffic and Transport Regulations, 2001

(ee) A flashing red pedal cycle or flashing green pedal cycle light signal

Indicates to a pedal cyclist-

(aaa) who has not yet commenced crossing the roadway that he or she shall not cross the roadway until the green pedal cycle light signal is displayed, or

(bbb) who is within a pedestrian crossing that the red pedal cycle light signal will follow shortly;

(ff) A steady green pedal cycle light signal

Indicates to a pedal cyclist that he or she may cross the junction within the cyclist crossing, as appropriate, and that the driver of a vehicle shall yield right of way to a cyclist crossing such junction.

B Red Flashing Signal:

Indicates to the driver of a vehicle that he or she shall stop his or her vehicle and shall not proceed until it is safe to do so, and such signal shall have the same significance as stop sign R1: Provided that when used at a railway crossing the signal shall indicate the approach of a train under which circumstances a driver shall stop his or her vehicle and shall not proceed until the signal ceases to flash.

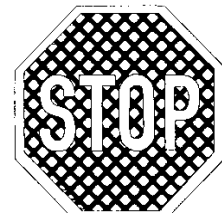

Railway crossing red flashing signal:

A railway crossing flashing signal shall conform to the requirements of the standard signals as shown in paragraph (2):

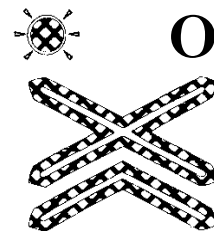

When two flashing red signals are used at a railway crossing, such signals must be used in conjunction with stop sign R1 and shall be displayed below sign R1, and the signals shall flash alternately to indicate the approach of a train and that the driver of a vehicle shall stop his or her vehicle and shall not proceed until the signals cease to flash, and it is safe to do so.

C Overhead Lane Direction Control Signals:

(a) S16: A steady green downward-pointing arrow:

Indicates to the driver of a vehicle that he or she may drive his or her vehicle in the lane over which the arrow is displayed.

(b) S17: A steady red cross:

Indicates to the driver of a vehicle that he or she shall not drive his vehicle in the lane over which the cross is displayed and that the lane is open to vehicles travelling in the opposite direction.

(c) S18 and S19: Yellow arrow left and right

Indicates to the driver of a vehicle that the lane over which the arrow is displayed is closed ahead and that he or she shall leave the lane in the direction of the arrow when it is safe to do so.

D Other regulatory signals

(a) Control hand signals for use by traffic officers:

REGULATIONS
Road Traffic and Transport Act 22 of 1999
Road Traffic and Transport Regulations, 2001

SS1

- (i) Hand signal to stop traffic approaching from the front.
 Indicates to the driver of a vehicle approaching a traffic officer from the front, who is displaying the signal, that he or she shall stop until the signal referred to in subparagraph (iv) is displayed.
- (ii) Hand signal to stop traffic approaching from the rear
 Indicates to the driver of a vehicle approaching a traffic officer from the rear who is displaying the sign that he or she shall stop until the signal referred to in subparagraph (iv) is displayed.
- (iii) Hand signal to stop traffic approaching from the front and the rear.
 Indicates to the driver of a vehicle, approaching a traffic officer from the front or rear who is displaying the signal that he or she shall stop until the signal referred to in subparagraph (iv) is displayed; or
- (iv) Hand signal to show traffic to proceed from the front, left or right.
 Indicates to the driver of a vehicle that he or she may proceed if a traffic officer displays the signal.



(b) Flag signals: SS2

- (i) Flag signal to stop.
 Indicates to the driver of a vehicle that he or she shall stop until the flag signal referred to in sub-paragraph (ii) is displayed.
- (ii) Flag signal to proceed.
 Indicates to the driver that he or she shall proceed when the flag signal is displayed.

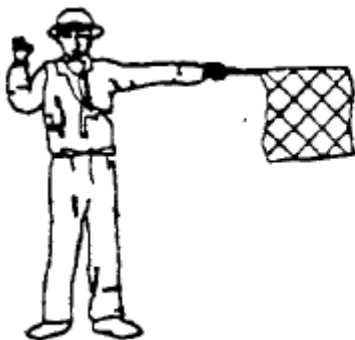

REGULATIONS
Road Traffic and Transport Act 22 of 1999
Road Traffic and Transport Regulations, 2001

- (2) A traffic signal shall only display light signals arranged to conform to the diagrams as shown below –

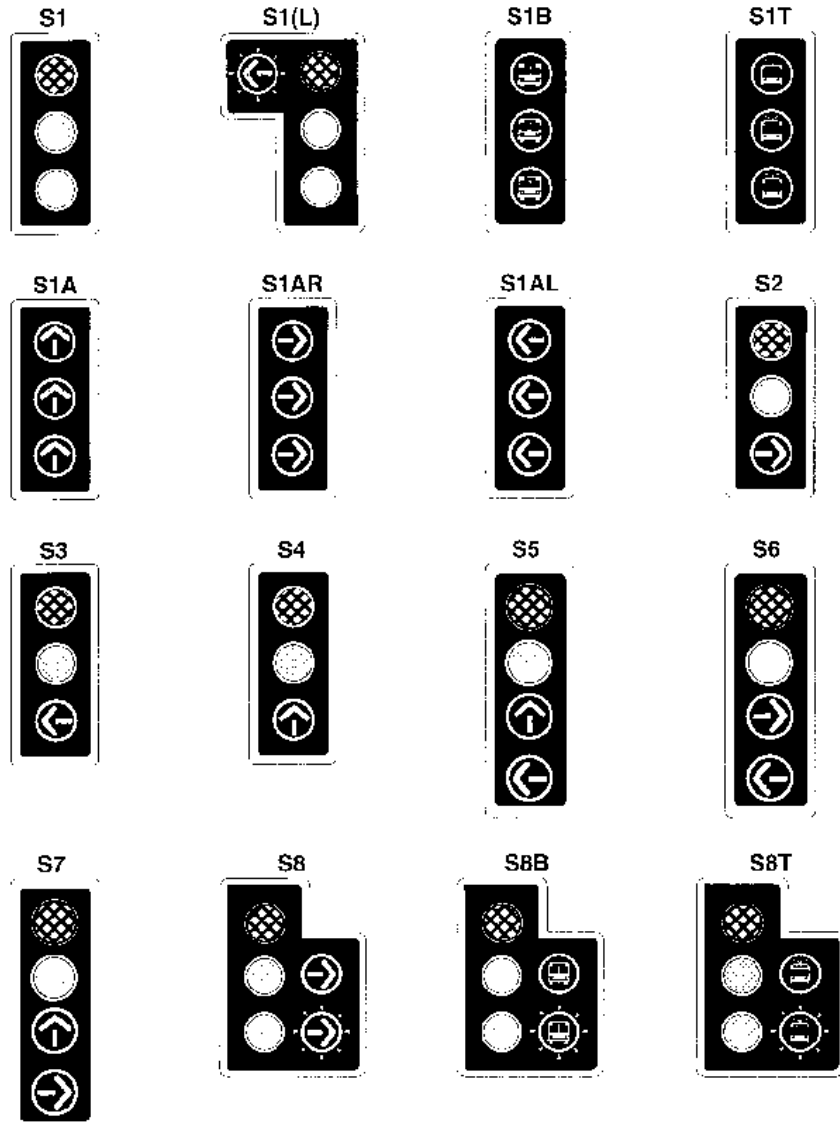

REGULATIONS
Road Traffic and Transport Act 22 of 1999
Road Traffic and Transport Regulations, 2001

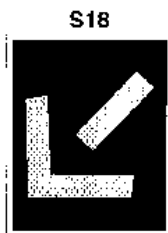
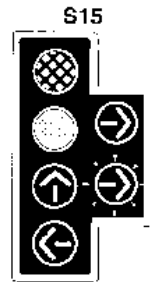
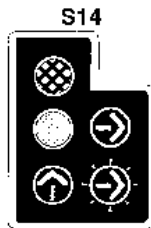
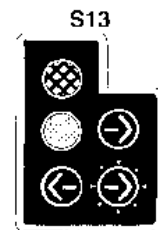
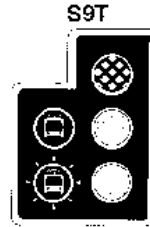
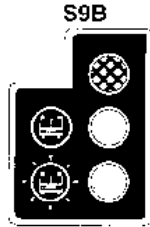
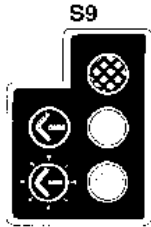

REGULATIONS
Road Traffic and Transport Act 22 of 1999
Road Traffic and Transport Regulations, 2001

- (3) A traffic signal installed before the implementation of these regulations which does not conform to any of the diagrams shown in item (2) may be displayed until 31 December 2003.
- (4) An overhead lane direction control signal shall be used to control the direction of movement in a particular lane of a public road so that road users may use the lane in one direction during certain periods of the day and in the opposite direction during other periods.
- (5) (a) A traffic signal shall -
- (i) comprise light signals arranged vertically so that the topmost signal is red, the central signal is yellow and the lower signal is green: Provided that -
 - (aa) the central light signal may include more than one yellow light signal arranged horizontally;
 - (bb) the lower light signal may include more than one green light signal arranged vertically or horizontally;
 - (cc) a special supplementary traffic signal S10 may be used with only a yellow or green arrow;
 - (dd) a pedestrian traffic signal S11 shall comprise two light signals arranged vertically and the upper light signal shall be red and the lower light signal shall be green;
 - (ee) a special traffic signal S12 may comprise two light signals arranged vertically and the upper light signal shall be red and the lower light signal green;
 - (ii) have a basic sequence which shall be red, green and yellow and the cycle time shall be such as required by the movement of traffic; and
 - (iii) be so designed that the traffic signal head prevents, as far as possible, any traffic signal from being seen from a direction to which its light signals do not apply.
- (b) There shall, at a junction or signalised pedestrian crossing, be at least two traffic signals for the control of vehicular traffic for each direction from which vehicular traffic may approach the junction or pedestrian crossing and these two traffic signals, shall be arranged so that both are on the far side of the junction and that there is one on either side of the roadway: Provided that -
- (i) when a light signal is provided specifically for turning vehicular traffic, only one traffic signal shall be required for the control of such traffic and such light signal may be located on the left side of the roadway provided it is sufficiently distanced from the stop line RTM1 so that drivers which stop behind the line can see the full traffic signal;
 - (ii) when the roadway is a divided roadway the right hand traffic signal shall be situated on the median island, and for the purpose of this subparagraph a

REGULATIONS
Road Traffic and Transport Act 22 of 1999
Road Traffic and Transport Regulations, 2001

median island is a constructed island with a width of not less than 900 millimetres measured at the nearest point to the intersection;

- (iii) when the required traffic signals cannot readily be seen by a driver of an approaching vehicle an additional traffic signal may be provided -
 - (aa) as an additional traffic signal on the far side of the junction;
 - (bb) as an additional traffic signal on the near side of the junction; or
 - (cc) as an elevated traffic signal situated above the roadway;
- (c) When it is necessary to increase the conspicuousness of a traffic signal in relation to its background, a background screen may be provided and such a screen shall comply with the Standard Specification for Traffic Lights: SABS 1459-1988.
- (d) The traffic signals at a junction shall be -
 - (i) not less than three metres apart;
 - (ii) not more than 20 metres apart: Provided that in the case where it is unavoidable that the traffic signals are more than 20 metres apart, an additional traffic signal facing in the same direction as the other traffic signals shall be installed in such a manner that no adjacent traffic signals are more than 16 metres apart.
- (e) When a separate right hand turn light signal is required at least two traffic signals that incorporate a green arrow light signal shall be provided and at least one of such traffic signals shall be a S8 traffic signal.
- (6) The traffic control at a junction or pedestrian crossing may include the use of road signs, road markings and road signals and the traffic control precedence shall be as follows -
 - (a) a road sign which prohibits or prescribes directional movement of traffic at a junction or pedestrian crossing which is controlled by a traffic signal shall have precedence over any light signal which permits right-of-way; and
 - (b) a light signal which has the significance that traffic shall stop has precedence over any other road traffic sign.
- (7) No road sign except -
 - (a) a street name sign;
 - (b) a direction route marker sign;
 - (c) an information sign relating to the function of the traffic signal;
 - (d) a one-way roadway sign;
 - (e) a no entry sign;
 - (f) a left turn prohibited, right turn prohibited or u-turn prohibited sign; or

REGULATIONS
Road Traffic and Transport Act 22 of 1999
Road Traffic and Transport Regulations, 2001

- (g) a proceed straight only, proceed left only, or proceed right only sign,
 shall be used in conjunction with a traffic signal, and such signs may be mounted on the same post.
- (8) When no light signal is illuminated at a junction, the driver of a vehicle shall act as for a 3-way stop sign R1.3 or a 4-way stop sign R1.4.
- (9) A flashing yellow disc light signal shall only be used on two opposite approaches to an intersection in conjunction with a flashing red disc light signal on the other two opposite approaches.
- (10) A flashing red arrow light signal shall not be used in conjunction with a green man light signal at an intersection.
- (11) Every flashing light signal shall operate at a cycle frequency of between one and two flashes per second.
- (12) (a) A flashing red signal shall comprise a single red disc light signal.
- (b) When a red flashing signal is used at a railway crossing the light signal shall -
- (i) be mounted above railway line hazard marker W403 or W404, as the case may be;
 - (ii) be illuminated in a flashing mode only when a train is approaching; and
 - (iii) be situated on the near side of the railway crossing, on both sides of each approach roadway.
- (c) Two red flashing signals may be provided and these may flash alternately.
- (13) (a) The responsible registered engineer of the road authority concerned shall approve and sign a declaration containing the description of -
- (i) the appropriate type of control;
 - (ii) phasing, time plans and off-set settings;
 - (iii) number, type and location of light signals;
 - (iv) road layout and the channelisation of traffic; and
 - (v) pedestrian facilities,
- for each traffic signal installed.
- (b) The declaration referred to in subitem (a) shall be kept by the road authority in control of the traffic signal concerned.
- (14) A sliplane for traffic turning left at an intersection which is traffic signal controlled, shall be separated from the lane to the right of such sliplane by a constructed island.

REGULATIONS
Road Traffic and Transport Act 22 of 1999
Road Traffic and Transport Regulations, 2001

- (15) Overhead lane direction control signals shall -
- (a) comprise two light signals, S16 and S17, mounted side by side with S16 on the right of S17 as viewed by a driver, above each lane subjected to reversed flow traffic movement and for both directions of movement, provided that, if the light signal is a matrix of light sources the signal may comprise one unit for each lane and for both directions of movement in that lane;
 - (b) conform to the requirements of the South African Standard Specification for Traffic Lights: SABS 1459-1988;
 - (c) be so mounted that the centre of the light signals is not more than six comma two metres above the roadway and the lower edge not less than five comma two metres above the roadway; and
 - (d) not be displayed over a lane to indicate the permitted direction of traffic movement except when such lane is subject to reversed flow in the direction of traffic movement.
- (16) A flag used for signalling shall be 600 millimetres by 600 millimetres and shall be red or orange.

(ii) Warning signals

- (1) Warning signals are classified in the following categories:

- A Warning flashing signal; and
- B Warning flag signals.

A. Warning Flashing Signal

A yellow flashing warning signal warns a road user of the presence of a particular hazard or traffic control device.

B. Warning Flag Signals

A warning flag signal warns a road user to proceed slowly and be alert.

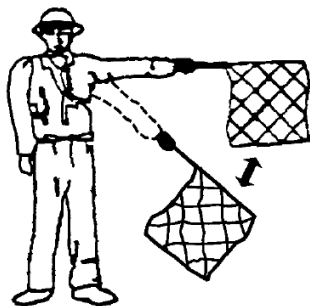

- (2) A yellow flashing signal comprises a single yellow disc light signal.

REGULATIONS
Road Traffic and Transport Act 22 of 1999
Road Traffic and Transport Regulations, 2001

SCHEDULE 3

[Schedule 3 is deleted by GN 86/2017.]

SCHEDULE 4

[Schedule 4 is amended by GN 97/2001 and by GN 103/2002, and deleted by GN 163/2002.]

SCHEDULE 5

[Schedule 5 is amended by GN 163/2002 and by GN 163/2002, and deleted by GN 2/2008.]

SCHEDULE 6

[Schedule 6 is deleted by GN 2/2008.]